

November 2024



# Settlements Residue Allocation Methodology for Designated Network Assets



For information about Powerlink Queensland, visit [www.powerlink.com.au](http://www.powerlink.com.au).

**Contact**

For enquiries about this Settlements Residue Allocation Methodology for Designated Network Assets, please contact:

Manager, Pricing and Billing

Powerlink Queensland

PO Box 1193

VIRGINIA QLD 4014

Email: [pppricing@powerlink.com.au](mailto:pppricing@powerlink.com.au)

**Version Control**

<b>Version</b>	<b>Date</b>	<b>Comments</b>	<b>Author</b>	<b>Approved</b>
1.0	December 2021	Initial issue	Ben Wu	Jennifer Harris
1.1	November 2024	First review	Sally Taylor	Jennifer Harris

## Table of Contents

1	Introduction and Rules requirements.....	5
2	Interpretation .....	5
3	Calculation of <i>settlements residue</i> that accrue on a <i>DNA</i> .....	5
3.1	<i>Inter-regional settlements residue</i> .....	5
3.2	<i>Intra-regional settlements residue</i> .....	6
4	Allocation and distribution of <i>settlements residue</i> .....	9
	Technical Appendix: Calculation of Estimated Losses over a <i>DNA</i> .....	10

## 1 Introduction and Rules requirements

Powerlink Queensland (Powerlink) is the *Primary Transmission Network Service Provider (TNSP)* in Queensland.

Clause 3.6.2B(f) of the National Electricity Rules (the Rules) requires Powerlink to:

- calculate the *settlements residue* that accrue on a *designated network asset (DNA)*; and
- distribute or recover those *settlements residue* from each owner of each *DNA* in accordance with the methodology developed by Powerlink as set out in the relevant *network operating agreement (NOA)* for that *DNA*.

This *settlements residue* allocation methodology (Allocation Methodology) for *DNAs* complies with the requirements imposed on Powerlink under the Rules and forms part of the standard NOA for *DNAs* that connect to Powerlink's transmission network.

## 2 Interpretation

All italicised terms in this Allocation Methodology have the meaning given to them in the Rules. A reference to the Rules is taken to be a reference to version 217 of the National Electricity Rules (which commenced operation on 10 October 2024) as amended from time to time.

This Allocation Methodology also adopts concepts and definitions from the Australian Energy Market Operator's Methodology for the Allocation and Distribution of Settlements Residue (AEMO's Methodology) (Version 3, which commenced on 2 June 2024), as amended from time to time.

This Allocation Methodology is to be read in conjunction with Powerlink's standard NOA for a third party *DNA*.

## 3 Calculation of *settlements residue* that accrue on a *DNA*

Consistent with AEMO's Methodology, the calculation of *settlements residue* that accrue on a *DNA* comprises:

- *inter-regional settlements residue* that apply for each direction of flow over the regulated interconnector between the Queensland and New South Wales regional reference nodes; and
- *intra-regional settlements residue* within Queensland's transmission network.

### 3.1 *Inter-regional settlements residue*

For the avoidance of doubt, the *inter-regional settlements residue* that accrue on a *DNA* are taken to be zero for the purposes of this Allocation Methodology.

### 3.2 Intra-regional settlements residue

Powerlink will use the following approach to calculate *intra-regional settlements residue* that accrue on a *DNA*, unless otherwise agreed with a third party owner of a *DNA* under a NOA. Powerlink may update this policy from time to time to reflect changes to the Rules, AEMO's Methodology or other applicable law.

Powerlink may apply an alternative calculation approach for a specific *DNA* under a NOA in circumstances such as, but not limited to where:

- the configuration of the specific *DNA* is not covered in the cases contemplated in the [Technical Appendix](#);
- Powerlink considers that implementing the standard calculation approach would not be appropriate, given the configuration of the *DNA*; and/or
- the *DNA* owner agrees to reimburse Powerlink for the costs involved in establishing a more accurate measure of settlements residue accruing on the *DNA*.

The latter may require, among other things, for Powerlink to install physical or logical *meters* at:

- any *DNA boundary point* that is directly upstream (i.e. located further from the existing transmission network) from the *DNA*, if applicable; and
- the *boundary point* or any intermediate *DNA boundary point* that is directly downstream (i.e. located closer to the existing transmission network) from the *DNA*.

The simplified transmission network diagram below shows the concepts and positioning of the *DNA* within the context of the customer site and the existing transmission network used to provide *prescribed transmission services*.

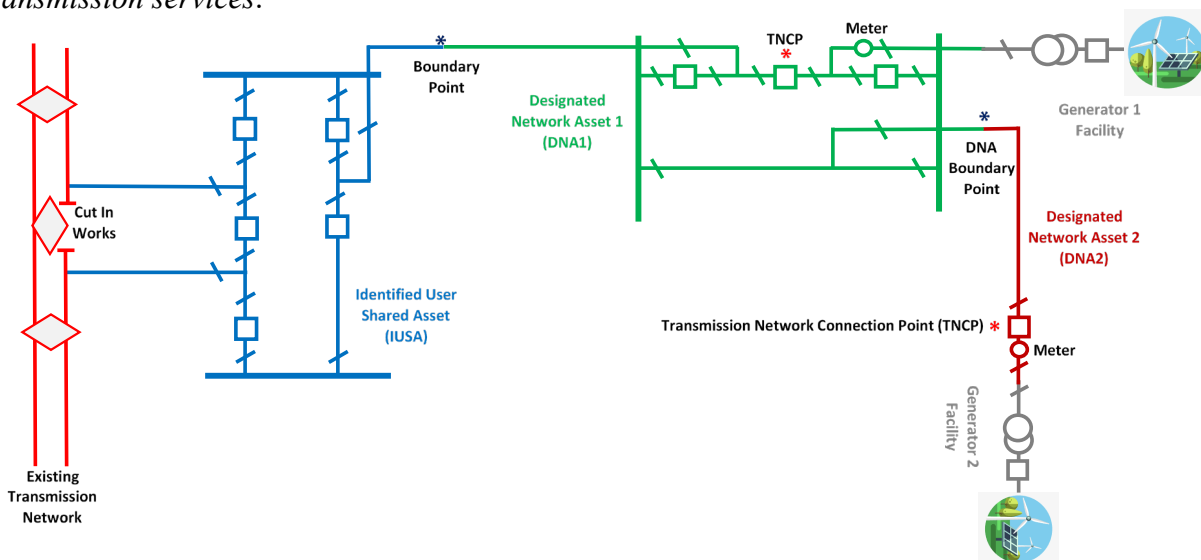

To calculate *intra-regional settlements residue* that accrue on a *DNA* without physical or logical *metering data* from the *boundary point* or *DNA boundary points*, as applicable, Powerlink will approximate the electrical losses over the *DNA* based on:

- the *metering data* at each *transmission network connection point* (TNCP) *meter* connected as part of the *DNA*;
- AEMO’s published *marginal loss factors* for any *DNA boundary point* that is directly upstream (i.e. located further from the existing transmission network) from the *DNA*, if applicable; and
- AEMO’s published *marginal loss factor* for the *boundary point* or *DNA boundary point* that is directly downstream (i.e. located closer to the existing transmission network) from the *DNA*.

Under this approach, the *DNA*’s *settlements residue* is determined by the formula:

$$RR_{DNA} = RRP \times \text{TimeFraction} \times \text{EstimatedLosses}_{DNA}, \quad \text{Equation (1)}$$

where:

- $RR_{DNA}$  is the *intra-regional settlements residue* accruing on the *DNA*;
- $RRP$  is the *regional reference price* for Queensland (in \$ per megawatt hour);
- $\text{TimeFraction}$  is the length of the interval for the *metering data* at all TNCPs connected as part of the *DNA* in hours (e.g. a five-minute interval is 1/12 h); and
- $\text{EstimatedLosses}_{DNA}$  is an approximation of the electrical losses in generation or consumption across the *DNA* based on *marginal loss factors*.

The approach to calculate  $\text{EstimatedLosses}_{DNA}$  depends on:

- the types of assets (e.g. generators, loads and batteries) connected to the *DNA*; and
- whether any upstream or downstream *DNAs* are connected to the *DNA*.

The [Technical Appendix](#) provides more detail on these calculations based on various potential configurations for the *DNA*. We provide a simple example below to illustrate the calculation process when only one asset – in this case, a generator – is connected to the *DNA*.

Example 1: Terminal *DNA* connected to the existing transmission network with one connecting party

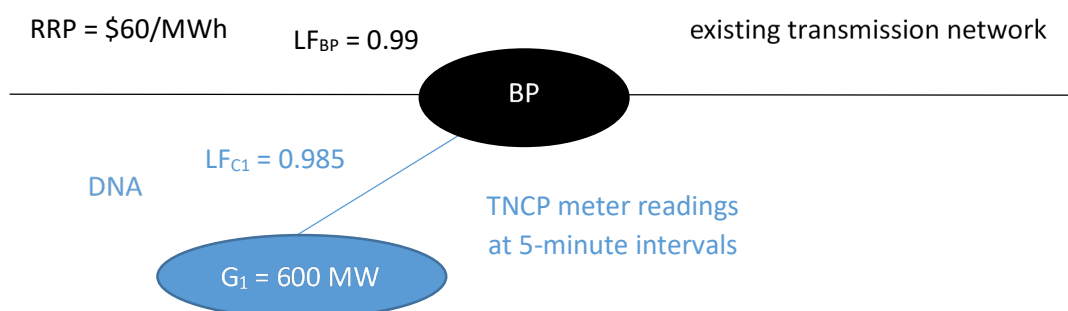

Intuitively, the estimated losses over the *DNA* reflect the difference in estimated energy at the *regional reference node* based on the hypothetical situation where the asset was located at the *boundary point* or *DNA boundary point*. In the example above:

- the energy received at the *regional reference node* from the generator is estimated to be 591 MW (i.e.  $0.985 \times 600$  MW); and
- the estimated energy received at the *regional reference node* from the generator, were it to be located at the boundary point, would be 594 MW (i.e.  $0.99 \times 600$  MW).

This means that the estimated electrical losses that accrue over the *DNA* are 3 MW (i.e.  $594 \text{ MW} - 591 \text{ MW}$ ).

Combining this with the *regional reference price* and *metering data* interval means that, according to Equation (1), the *settlements residue* that accrues on the *DNA* over this particular five-minute interval is:

$$RR_{DNA} = RRP \times \text{TimeFraction} \times \text{EstimatedLosses}_{DNA} = \$ 60 / \text{MWh} \times 1/12 \text{ h} \times 3 \text{ MW} = \$15.$$



## 4 Allocation and distribution of *settlements residue*

The following approach will apply to all *DNAs* connecting directly or indirectly to Powerlink's existing transmission network, unless otherwise documented in the relevant NOA for the *DNA*.

*Settlements residue* that accrue on *DNAs* will be calculated on a calendar month basis using the formulae in [section 3](#) and the [Technical Appendix](#) for each time interval for *metering data* within that calendar month. Powerlink will issue a statement or invoice that documents these calculations to *DNA* owners in accordance with the relevant NOA for the *DNA*.

Where the amount of *settlements residue* is positive, Powerlink will pay the *DNA* owner(s) the amount due in accordance with the relevant NOA for the *DNA*.

Where the amount of *settlements residue* is negative, which may occur when the regional reference price is negative for an extended period, the *DNA* owner(s) will be required to pay Powerlink the amount due in accordance with the relevant NOA for the *DNA*.

## Technical Appendix: Calculation of Estimated Losses over a DNA

This technical appendix provides further information and worked examples of how estimated losses will be calculated for the purposes of *settlements residue* allocation for more complex potential DNA network configurations.

Powerlink will apply the following procedure for each time interval for *metering data* to determine estimated losses for the DNA shown in Equation (1).

Terminal DNA (i.e. one that does not connect to any upstream DNA boundary points)

**Case 1:** DNA contains only generators or loads (but not battery storage devices)

a. Use the following formula to determine the estimated losses on the DNA:

$$\text{EstimatedLosses}_{\text{DNA}} = \sum [(-1)^{n_i} \times E_i \times (LF_{\text{BP-D}} - LF_{E_i})], \quad \text{Equation (2)}$$

where:

- $E_i$  is the metered amount of energy at the TNCP asset  $i$  produces or consumes within the DNA;
  - $n_i$  is an indicator variable which takes the value 0 if asset  $i$  is a net generator within the time interval for the *metering data* and 1 if it is a net consumer;
  - $LF_{\text{BP-D}}$  is the marginal loss factor published by AEMO for the downstream *boundary point* or *DNA boundary point*; and
  - $LF_{E_i}$  is the *marginal loss factor* published by AEMO related to asset  $i$  within the DNA.
- b. If the DNA is connected to the existing transmission network via a downstream *DNA boundary point*, use the following formula to estimate the amount exported to (imported from) upstream sources:

$$\text{DownstreamFlow}_{\text{DNA}} = \sum [(-1)^{n_i} \times E_i \times LF_{E_i} / LF_{\text{BP-D}}], \quad \text{Equation (3)}$$

where a negative value implies importing from downstream sources.

**Case 2:** Mixed development DNA (i.e. contains a mix of generators, loads and/or battery storage devices)

- a. Determine the net energy export (import) position within the DNA based on metered generation/consumption at the TNCP. Note this assumes that intra-DNA electrical losses are negligible.
- b. Allocate the net energy exported (imported) based on *metering data* to generators (loads) proportional to their metered output. For a net exporting (importing) DNA, this rescaling process sets loads (generators) to zero.
- c. Use the following formula to determine the estimated losses on the DNA:

$$\text{EstimatedLosses}_{\text{DNA}} = \sum [(-1)^{n_i} \times E^*_i \times (\text{LF}_{\text{BP-D}} - \text{LF}_{\text{Ei}})], \quad \text{Equation (4)}$$

where  $n_i$ ,  $\text{LF}_{\text{Ei}}$  and  $\text{LF}_{\text{BP-D}}$  are as defined in (2) and  $E^*_i$  is the metered generation or consumption by asset  $i$  rescaled to the *DNA*'s net position in step b.

- d. If the *DNA* is connected to the existing transmission network through a downstream *DNA boundary point*, use the following formula to estimate the amount exported to (imported from) downstream sources:

$$\text{DownstreamFlow}_{\text{DNA}} = \sum [(-1)^{n_i} \times E^*_i \times \text{LF}_{\text{Ei}} / \text{LF}_{\text{BP-D}}]. \quad \text{Equation (5)}$$

Non-terminal *DNA* (i.e. connections to upstream *DNAs* via *DNA boundary points*)

**Case 3:** *DNA* contains only generators (loads) and exporting (importing) upstream *DNAs*

- a. Use the following formula to determine the estimated losses on the *DNA*:

$$\text{EstimatedLosses}_{\text{DNA}} = \sum [(-1)^{n_i} \times E_i \times (\text{LF}_{\text{BP-D}} - \text{LF}_{\text{Ei}})] + \sum [(-1)^{m_j} \times \text{UpstreamFlow}_j \times (\text{LF}_{\text{BP-D}} - \text{LF}_{\text{BP-Uj}})], \quad \text{Equation (6)}$$

where  $n_i$ ,  $E_i$ ,  $\text{LF}_{\text{Ei}}$  and  $\text{LF}_{\text{BP-D}}$  are as defined in Equation (2) and:

- $m_j$  is an indicator variable which takes the value 0 if *boundary point j* records a net inflow to the *DNA* within the time interval for the *metering data* and 1 if it records a net outflow;
  - $\text{UpstreamFlow}_j$  is the estimated flow from upstream *DNA boundary point j* calculated using Equation (5) or Equation (9) as appropriate; and
  - $\text{LF}_{\text{BP-Uj}}$  is the *marginal loss factor* published by AEMO for upstream *DNA boundary point j* that connects to the *DNA*.
- b. If the *DNA* is connected to the existing transmission network via a downstream *DNA boundary point*, use the following formula to estimate the amount exported to (imported from) upstream sources:

$$\text{DownstreamFlow}_{\text{DNA}} = \sum [(-1)^{n_i} \times E_i \times \text{LF}_{\text{Ei}} / \text{LF}_{\text{BP-D}}] + \sum [(-1)^{m_j} \times \text{UpstreamFlow}_j \times \text{LF}_{\text{BP-Uj}} / \text{LF}_{\text{BP-D}}], \quad \text{Equation (7)}$$

where a negative value implies importing from downstream sources.

**Case 4:** Mixed development (i.e. contains a mix of generators, loads and/or battery storage devices) *DNA* and/or contains a mix of exporting and importing upstream *DNAs*

- a. Determine the net energy export (import) position within the *DNA* based on metered generation/consumption at the TNCP and the estimated flows calculated from upstream *DNAs*.

- b. Allocate the net energy exported (imported) based on *metering data* to generators (loads) and/or upstream *DNAs* proportional to their metered output or estimated flow as applicable. For a net exporting (importing) *DNA*, this rescaling process sets loads (generators) and importing (exporting) upstream *DNAs* to zero.
- c. Use the following formula to determine the estimated losses on the *DNA*:

$$\text{EstimatedLosses}_{DNA} = \sum[(-1)^{n_i} \times E^*_i \times (LF_{BP-D} - LF_{Ei})] + \sum[(-1)^{m_j} \times \text{UpstreamFlow}^*_j \times (LF_{BP-D} - LF_{BP-Uj})], \quad \text{Equation (8)}$$

where:

- $n_i$ ,  $LF_{Ei}$  and  $LF_{BP-D}$  are as defined in Equation (2);
  - $E^*_i$  is defined as in Equation (4);
  - $m_j$  and  $LF_{BP-Uj}$  are defined as in Equation (6); and
  - $\text{UpstreamFlow}^*_j$  the estimated flow by upstream *DNA j* rescaled to the *DNA's* net position in step b.
- d. If the *DNA* is connected to the existing transmission network through a downstream *DNA boundary point*, use the following formula to estimate the amount exported to (imported from) downstream sources:

$$\text{DownstreamFlow}_{DNA} = \sum[(-1)^{n_i} \times E^*_i \times LF_{Ei} / LF_{BP-D}] + \sum[(-1)^{m_j} \times \text{UpstreamFlow}^*_j \times LF_{BP-Uj} / LF_{BP-D}]. \quad \text{Equation (9)}$$

#### Notes in applying this procedure for the four cases

- A. For assets where bi-directional energy flows are possible, such as batteries or upstream boundary points, energy inflows and outflows within a TNCP *metering data* interval will be treated as if they were attributable to different assets for the purposes of this formula.
- B. Where there is a mixture of load and generation assets within a *DNA*, then the lower resistance of electricity transfer will mean loads will consume from generators within the *DNA* in the first instance. This “netting off” approach treats intra-*DNA* transmission losses as zero for calculating the *settlements residue* that accrue over the *DNA*.
- C. In situations where *DNAs* are “daisy-chained” behind the *boundary point*, the calculation of estimated losses accruing on a *DNA* requires the estimated flows from all directly upstream *DNAs* to be calculated first. Powerlink will therefore calculate the net positions across all terminal *DNAs* first, with the estimated losses determined progressively downstream towards the *boundary point* with the existing transmission network.

Example 2: Load-only terminal DNA connected to the existing transmission network

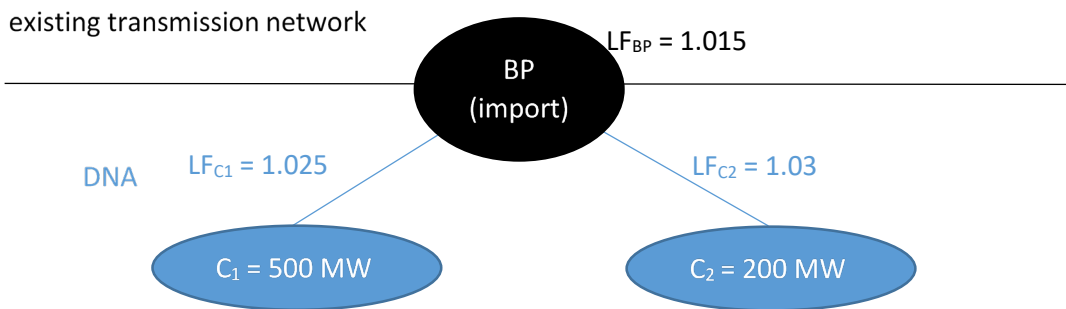

This is a load-only terminal DNA connected to the existing transmission network, so the only calculation required relates to the estimated losses calculated using the process outlined in [Case 1](#) (see page 10).

$$\begin{aligned}
 & \text{EstimatedLosses}_{DNA} \\
 &= \sum [(-1)^{n_i} \times E_i \times (LF_{BP-D} - LF_{E_i})] \\
 &= -1 \times 500 \times (1.015 - 1.025) + -1 \times 200 \times (1.015 - 1.03) \\
 &= 8 \text{ MW}
 \end{aligned}$$

Example 3: Generation-only non-terminal DNA with downstream DNA

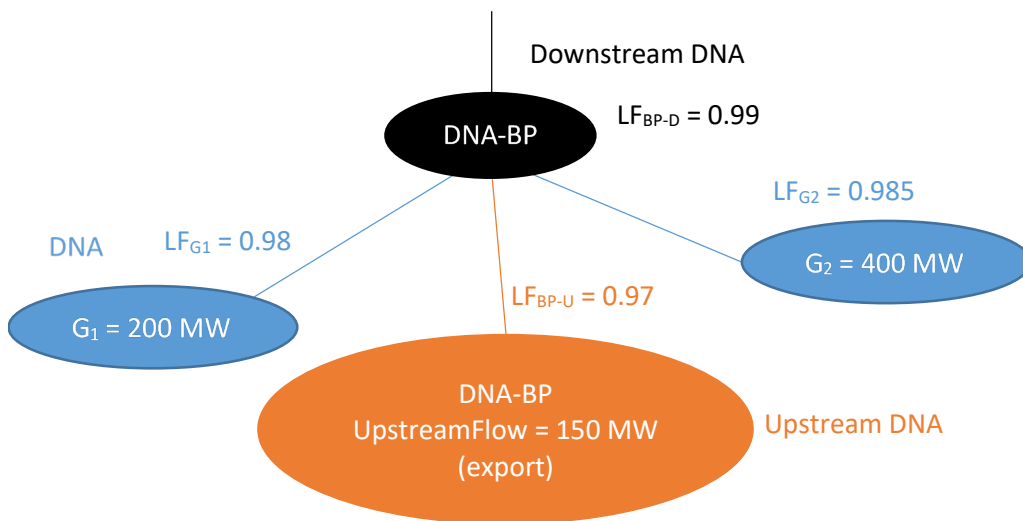

This DNA contains only generation assets, an exporting upstream DNA and a downstream DNA, so the calculations required are estimated losses and downstream flows using the process outlined in [Case 3](#) (see page 11).

$$\begin{aligned}
 & \text{EstimatedLosses}_{DNA} \\
 &= \sum [(-1)^{n_i} \times E_i \times (LF_{BP-D} - LF_{E_i})] + \sum [(-1)^{m_j} \times \text{UpstreamFlow}_j \times (LF_{BP-D} - LF_{BP-U_j})] \\
 &= 1 \times 200 \times (0.99 - 0.98) + 1 \times 400 \times (0.99 - 0.985) + 1 \times 150 \times (0.99 - 0.97)
 \end{aligned}$$

= 7 MW

$$\begin{aligned} & \text{DownstreamFlow}_{DNA} \\ &= \sum [(-1)^{(n_i)} \times E_i \times LF_{E_i} / LF_{BP-D}] + \sum [(-1)^{(m_j)} \times \text{UpstreamFlow}_j \times LF_{BP-U_j} / LF_{BP-D}] \\ &= 1 \times 200 \times 0.98 / 0.99 + 1 \times 400 \times 0.985 / 0.99 + 1 \times 150 \times 0.97 / 0.99 \\ &\approx 742.93 \text{ MW} \end{aligned}$$

Example 4: Mixed development non-terminal DNA

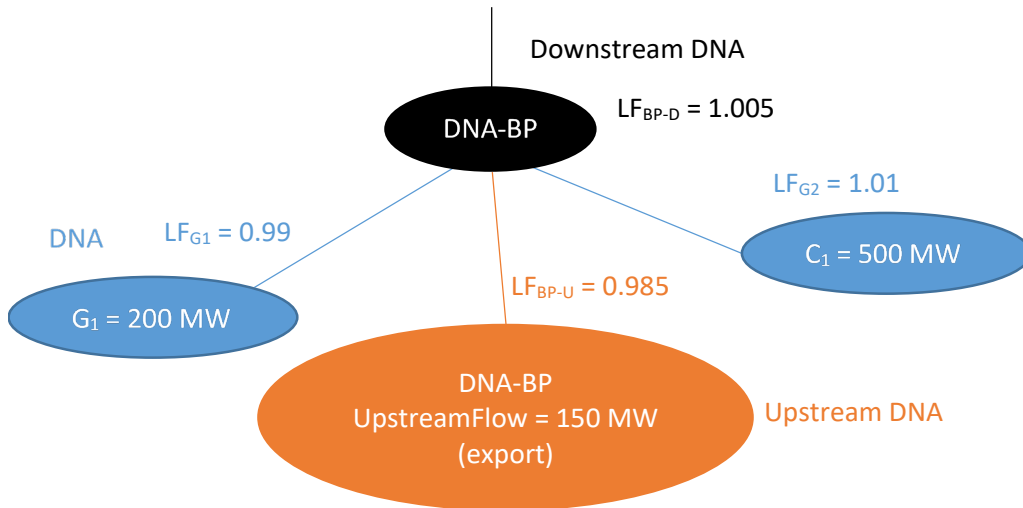

This DNA contains a mix of generation and load assets and has a downstream DNA, so the calculations required are estimated losses and downstream flows using the process outlined in [Case 4](#) (see page 11).<sup>1</sup>

The netting out within the DNA, as per step b in [Case 4](#) (see page 11), results in an equivalent “reduced form” network with one load.

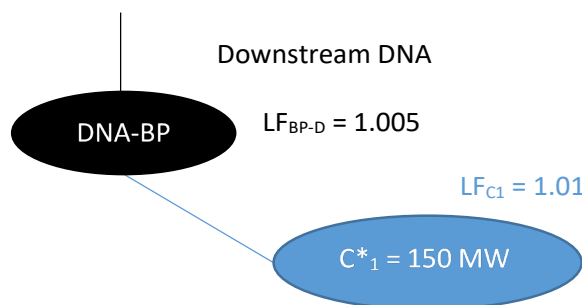

$$\begin{aligned} & \text{EstimatedLosses}_{DNA} \\ &= \sum [(-1)^{(n_i)} \times E^*_i \times (LF_{BP-D} - LF_{E_i})] + \sum [(-1)^{(m_j)} \times \text{UpstreamFlow}^*_j \times (LF_{BP-D} - LF_{BP-U_j})] \end{aligned}$$

<sup>1</sup> In the absence of an upstream DNA, this example would have fallen into [Case 2](#) (see page 10) in this methodology.

$$\begin{aligned} &= -1 \times 150 \times (1.005 - 1.01) + 0 \\ &= 0.75 \text{ MW} \end{aligned}$$

$$\begin{aligned} &\text{DownstreamFlow}_{DNA} \\ &= \sum [(-1)^{n_i} \times E^*_i \times LF_{E_i} / LF_{BP-D}] + \sum [(-1)^{m_j} \times \text{UpstreamFlow}^*_j \times LF_{BP-U_j} / LF_{BP-D}] \\ &= -1 \times 150 \times 1.01 / 1.005 + 0 \\ &\approx -150.75 \text{ MW (i.e. imports from the downstream DNA)} \end{aligned}$$

