



CALVALE TO CALLIOPE RIVER TRANSMISSION LINE REINFORCEMENT PROJECT

Surface Water Assessment – Public Environment Report

Umwelt (Australia) Pty Ltd on behalf of Powerlink Queensland

6 March 2026

2254-02-B5

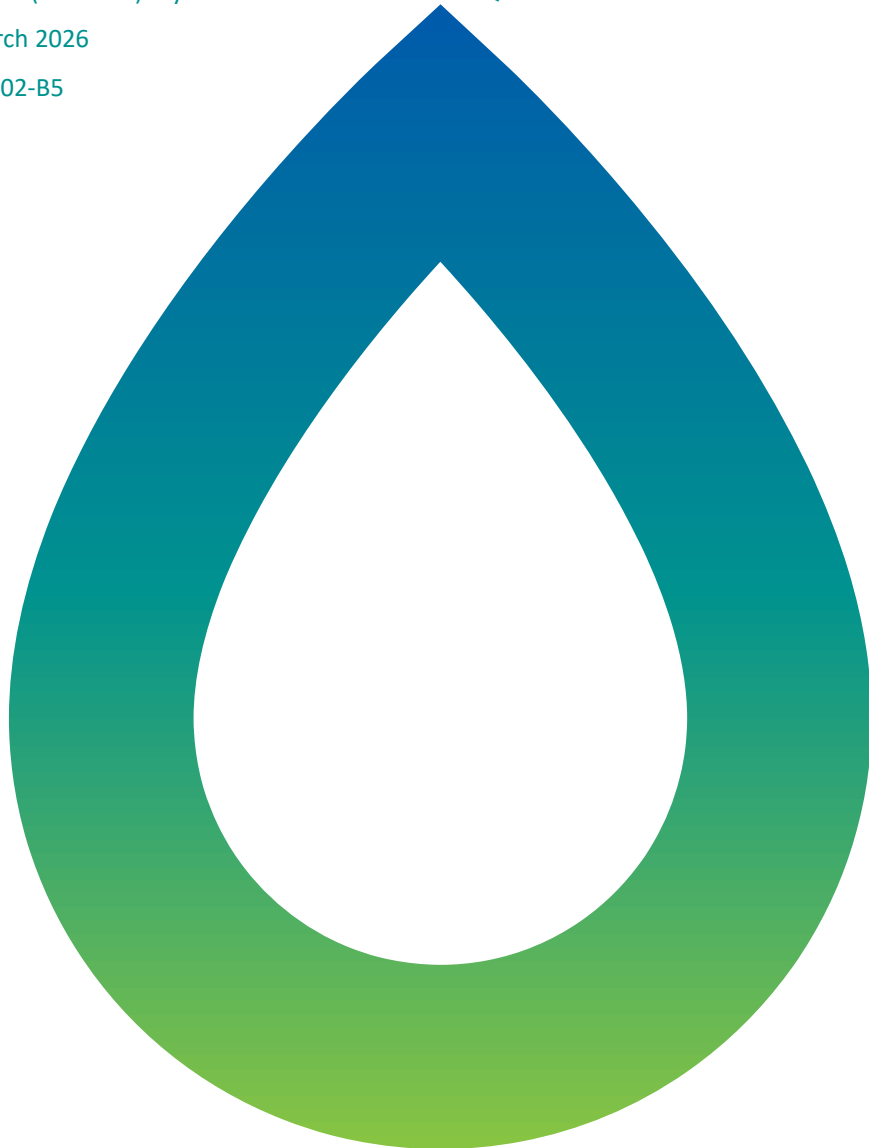

DETAILS

Report Title	Calvale to Calliope River Transmission Line Reinforcement Project, Surface Water Assessment – Public Environment Report
Client	Umwelt (Australia) Pty Ltd

THIS REVISION

Report Number	2254-02-B5
Date	6 March 2026
Author	TJP
Reviewer	Lindsay Millard

NOTE: This report has been prepared on the assumption that all information, data and reports provided to us by our client, on behalf of our client, or by third parties (e.g. government agencies) is complete and accurate and on the basis that such other assumptions we have identified (whether or not those assumptions have been identified in this advice) are correct. You must inform us if any of the assumptions are not complete or accurate. We retain ownership of all copyright in this report. Except where you obtain our prior written consent, this report may only be used by our client for the purpose for which it has been provided by us.

DETAILS

Report Title	Calvale to Calliope River Transmission Line Reinforcement Project, Surface Water Assessment – Public Environment Report
Client	Umwelt (Australia) Pty Ltd

THIS REVISION

Report Number	2254-02-B5
Date	6 March 2026
Author	Tarkan Pasin
Reviewer	Lindsay Millard

NOTE: This report has been prepared on the assumption that all information, data and reports provided to us by our client, on behalf of our client, or by third parties (e.g. government agencies) is complete and accurate and on the basis that such other assumptions we have identified (whether or not those assumptions have been identified in this advice) are correct. You must inform us if any of the assumptions are not complete or accurate. We retain ownership of all copyright in this report. Except where you obtain our prior written consent, this report may only be used by our client for the purpose for which it has been provided by us.

TABLE OF CONTENTS

1	INTRODUCTION	9
1.1	PROJECT OVERVIEW	9
1.2	PROJECT LOCATION AND CONTEXT	10
1.3	REPORT STRUCTURE AND METHODOLOGY	10
2	PROJECT DESCRIPTION	12
2.1	PROJECT COMPONENTS	12
2.1.1	Wire Stringing	12
2.2	CONSTRUCTION ACTIVITIES AND TIMELINE	16
2.2.1	Disturbance footprint	16
2.2.2	Proposed timeframes	16
2.2.3	Hardstand areas	16
2.2.4	Access tracks	16
2.2.5	Foundation Installation	16
2.3	OPERATION AND MAINTENANCE	16
2.4	PROJECT DESIGN STANDARDS	17
2.5	ACCESS REQUIREMENTS	17
3	LEGISLATIVE AND POLICY FRAMEWORK	18
3.1	OVERVIEW	18
3.2	COMMONWEALTH POLICY AND GUIDELINES	18
3.2.1	MNES Significant Impact Guidelines	18
4	EXISTING SURFACE WATER ENVIRONMENT	21
4.1	OVERVIEW	21
4.2	CLIMATE	22
4.2.1	Overview	22
4.2.2	Rainfall	22
4.3	TOPOGRAPHY AND DRAINAGE	24
4.3.1	Water Bodies and Waterway Classifications	27
4.4	FLOOD HISTORY	37
4.5	SOIL TYPES AND CHARACTERISTICS	38
5	MODELLING APPROACH	42
5.1	OVERVIEW	42
5.2	DESIGN RAINFALL DEPTHS	42
5.2.1	ARR Data Hub	43
5.2.2	Design rainfall losses and pre-burst rainfall	43
	Design temporal patterns	44
5.3	HYDRAULIC MODELLING	45
5.3.1	Topography and grid cell size	45
5.3.2	Boundary conditions	46
5.3.3	Hydraulic structures	46

5.3.4	Hydraulic resistance	47
6	FLOOD MODEL RESULTS AND ANALYSIS	50
6.1	OVERVIEW	50
6.2	LIMITATIONS	50
6.3	DESIGN FLOOD EVENTS	50
6.3.1	Current Climate	51
6.3.2	Future Climate Scenario	53
6.4	FLOOD VALIDATION	54
7	POTENTIAL IMPACTS ON MNES	57
7.1	OVERVIEW	57
7.2	ID#1 - RISK OF INCREASED SEDIMENT AND EROSION RUN-OFF	57
7.3	ID#2 - RISK OF IMPACTS ON STREAM STABILITY AND RIPARIAN HEALTH	58
7.4	ID#3 - RISK TO RECEIVING WATER QUALITY ASPECTS	58
7.5	ID#4 - RISK OF INCREASED SEDIMENT AND EROSION DUE TO FUTURE CLIMATE SCENARIO	59
7.6	ID#5 - RISK OF INCREASED IMPACTS ON STREAM STABILITY DUE TO FUTURE CLIMATE SCENARIO	59
8	MNES IMPACT ASSESSMENT	60
8.1	OVERVIEW	60
9	MITIGATION AND MANAGEMENT MEASURES	62
9.1	OVERVIEW	62
9.2	MITIGATION AND MANAGEMENT MEASURES	62
9.2.1	ID#1 - Mitigating an increase in sediment and erosion run-off	62
9.2.3	ID#3 - Mitigating Water Quality Impacts	64
9.3	ALIGNMENT WITH REEF 2050 WATER QUALITY IMPROVEMENT PLAN –	64
9.3.1	Reef 2050 Water Quality Improvement Plan 2017-2022	64
9.3.2	Reef 2050 Long-Term Sustainability Plan 2021-25	64
9.3.3	Water Plan (Calliope River Basin) 2006	65
9.3.4	Fitzroy Region Calliope catchment water quality target	65
9.4	CUMULATIVE IMPACTS	65
9.5	SUMMARY AND TIMING OF MEASURES	70
10	CONCLUSION	72
10.1	SUMMARY OF KEY FINDINGS	72
10.1.1	Flood Assessment Outcome	72
10.1.2	MNES and Water Quality	72
10.1.3	Water Quality Management Plan Framework	72
10.1.4	Cumulative Impacts	72
11	REFERENCES	73
12	ABBREVIATIONS AND DEFINITIONS	74

APPENDIX A MNES RISK AND MITIGATION TABLES

A.1 MNES RESPONSE TABLE

A.2 THE REEF LONG-TERM SUSTAINABILITY PLAN 2021-25

A.3 REEF 2050 WATER QUALITY IMPROVEMENT PLAN

APPENDIX B FLOOD MAPS

B.1 AERIAL IMAGERY OF CORRIDOR ALIGNMENT

B.2 REGIONAL FLOOD MAPPING – CURRENT CLIMATE

B.3 REGIONAL FLOOD MAPPING – FUTURE CLIMATE 2090 SSP3

APPENDIX C TOWER STANDARD DRAWINGS

FIGURES

Figure 1.1	Project locality	11
Figure 2.1	Indicative general arrangement of tower	13
Figure 2.2	Indicative typical detail of bored pile arrangements	14
Figure 2.3	Artist impression looking towards Tower CC183	14
Figure 2.4	Location of proposed tower sites	15
Figure 4.1	Annual total rainfall from synthetic daily rainfall data at the Project Area	23
Figure 4.2	Distribution of monthly rainfall and pan evaporation	23
Figure 4.4	Topographic data available	26
Figure 4.5	Topography and regional drainage characteristics A - B	28
Figure 4.6	Topography and regional drainage characteristics B - C	29
Figure 4.7	Topography and regional drainage characteristics C - E	30
Figure 4.8	Watercourse identification map (Water Act) A - B	31
Figure 4.9	Watercourse identification map (Water Act) B - C	32
Figure 4.10	Watercourse identification map (Water Act) C - E	33
Figure 4.11	Waterway characterisation map (Waterway barrier works) A - B	34
Figure 4.12	Waterway characterisation map (Waterway barrier works) B - C	35
Figure 4.13	Waterway characterisation map (Waterway barrier works) C - E	36
Figure 4.14	Flood frequency analysis at Calliope River at Castlehope (GS12300A)	38
Figure 4.15	Agricultural Land Classification	40
Figure 4.16	Australian Soil Classification	41
Figure 5.1	Flood depth results from LiDAR and Copernicus terrain in Section B	46
Figure 5.2	Flood depth results from Copernicus terrain only in Section B	46
Figure 5.3	Hydraulic model configuration	49
Figure 6.1	1% AEP from adjacent at-site FFA, nearby hydrologic models and RFFE output	55
Figure 6.2	10% AEP from adjacent at-site FFA, nearby hydrologic models and RFFE output	56

TABLES

Table 1.1	Project Sections	9
Table 4.1	Weather stations	22
Table 4.2	Calliope River at Castlehope (GS12300A) gauge peak flow events	37
Table 5.1	Adopted design rainfall depths – Current Climate	43
Table 5.2	Adopted design rainfall depths – Future Climate	43
Table 5.3	Adopted design rainfall losses	44
Table 5.4	Probability Neutral Burst Initial Loss - Current Climate	44
Table 5.5	Probability Neutral Burst Initial Loss - Future Climate (2090 SSP3)	44
Table 5.6	Adopted hydraulic roughness coefficients	47
Table 6.1	Estimates of peak discharge at key locations - Current Climate	52
Table 6.2	Estimates of peak discharges at key locations - Future Climate (2090 SSP3)	53
Table 6.3	Regional Flood Frequency Estimation of peak discharges	54
Table 6.4	Adjusted RFFE model peak discharge	56
Table 9.1	EPBC-referred projects within the 20 km buffer of the Project Area	67
Table 12.1	Key project terminology	74
Table 12.2	Flooding Abbreviations and Definitions	74
Table A.1	Regional Water Quality Targets	
Table A.2	End-of-catchment anthropogenic water quality targets for the Reef catchments by 2025 and relative priorities for water quality improvement	
Table A.3	REEF 2050 Objectives and Compliance	81

1 INTRODUCTION

1.1 PROJECT OVERVIEW

Umwelt (Australia) Pty Ltd (Umwelt), on behalf of Powerlink Queensland (Powerlink), is preparing a Public Environment Report (PER) for the Federal *Environmental Protection and Biodiversity Conservation* (EPBC) Act for the Calvale to Calliope River (C2C) Transmission Line Reinforcement Project (the Project).

The Project extends from 10 kilometres (km) east of Biloela to 2 km north of Clinton, near Gladstone, Queensland and traverses both the Gladstone Regional Council (GRC) and Banana Shire Council (BSC) Local Government Areas (LGA). The Project runs parallel with the existing Powerlink transmission infrastructure and is split into five sections, as detailed in Table 1.1.

Table 1.1 Project Sections

Section	Start of section	End of section	Approximate length	Existing Powerlink infrastructure
Section A	-24.3418, 150.6270	-24.3268, 150.6560	3.5 km	132 kV and 275 kV lines, Calvale substation
Section B	-24.3268, 150.6560	-23.9344, 150.9174	51.5 km	One 275 kV line
Section C	-23.9344, 150.9174	-23.9230, 151.0733	16 km	Two 275 kV lines
Section D	-23.9230, 151.0733	-23.8484, 151.1754	13.5 km	One 275 kV line
Section E	-23.8484, 151.1754	-23.8580, 151.1943	2 km	Two 275 kV lines, Calliope River substation

The Project is shown in Figure 1.1 and comprises the following components:

- A new double circuit, 275 kilovolt (kV) transmission line within a 60 metre (m) wide easement;
- New substation equipment such as reactors, transformers, synchronous condensers (potentially up to two (2)) and static synchronous compensation, as well as the expansion of the existing 132 kV and 275 kV switching yards at the Calliope River Substation;
- Steel lattice towers;
- Brake and winch sites;
- Laydown areas;
- Concrete batching plants;
- Mobile site offices; and,
- Upgrades to existing access tracks and new access tracks.

The Project area boundaries referred to throughout this report are defined as follows:

Project Area - The Project Area extends from the Calvale Substation site to the Calliope River Substation site and includes the existing powerline easement, with varying buffers for each section. The Project Area covers approximately 14,321 hectares (ha) and extends for 87 km.

Disturbance Footprint - The Disturbance Footprint represents the maximum extent of direct impacts and indicative locations of Project infrastructure within the Project Area (i.e. tower pads, new and widened access tracks, laydown areas, batch plants and brake and winch sites).

1.2 PROJECT LOCATION AND CONTEXT

Powerlink is planning for a new transmission line between the Calvale Substation (near Callide Power Station) and the Calliope River Substation (near Gladstone). The Project will reinforce electricity supply to the Gladstone region and increase network capacity and reliability to service the growing renewable energy industry in this area.

At 87 km long, the new double-circuit 275 kV transmission line will be co-located in an existing spare easement alongside the existing 275 kV transmission lines. However, there is approximately 16 km between Bracewell and East End, and approximately 450 m on the approach into the Calvale Substation, where easement widening is required.

Regarding the Great Barrier Reef Marine Park (GBRMP), the easternmost part of the Project, Section E, is approximately 16 kilometres from the nearest GBRMP boundary at The Narrows the Gladstone Harbour located between. The Project is also about 20 km and 30 km from the GBRMP boundaries near Southend and Tannum Sands, respectively.

1.3 REPORT STRUCTURE AND METHODOLOGY

The purpose of this report is to address the surface water aspects contained in the *Guidelines for a Draft Public Environment Report* - EPBC 2024/10044 (the PER guidelines) for the Project.

This report is structured as follows:

- Section 2 outlines the Project description and activities;
- Section 3 provides details of the regulatory framework;
- Section 4 describes the existing surface water environment;
- Section 5 presents the approach to modelling flooding;
- Section 6 discusses the results from flood modelling;
- Section 7 outlines the Water Management Objectives;
- Section 8 is a list of references;
- Section 9 is a list of abbreviations and definitions; and,
- Appendix A provides a mapping of corridor alignment and regional flood model results.

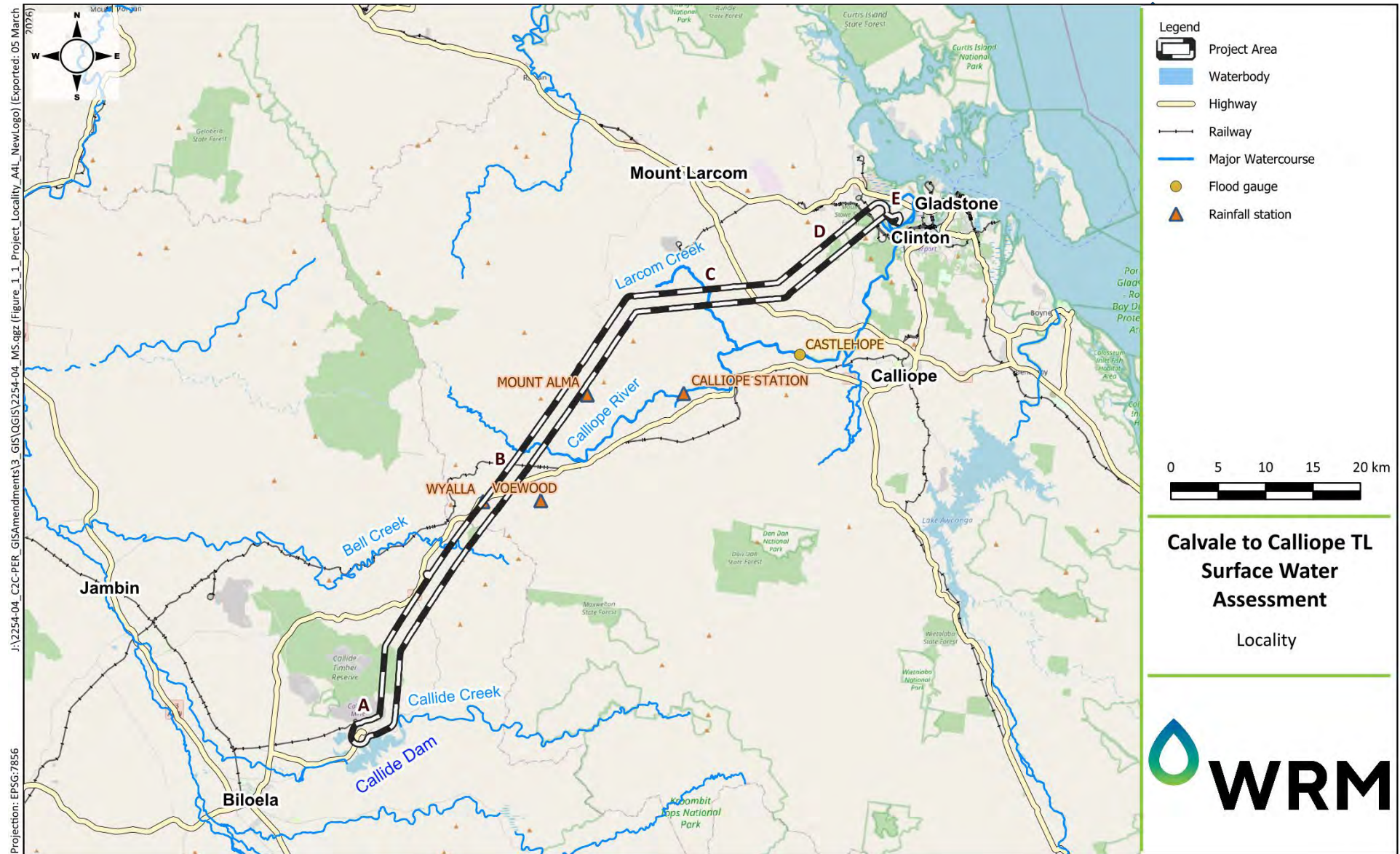

Figure 1.1 Project locality

2 PROJECT DESCRIPTION

2.1 PROJECT COMPONENTS

The Project involves the installation of prefabricated tower components assembled adjacent to the tower's construction sites. A large mobile crane will be used to erect the towers in sections. An indicative arrangement of the proposed tower is shown in Figure 2.1. Note that the arrangement shows minimal cross-sectional area at ground level, as the legs are tied to the bored piles, as shown in Figure 2.2. An artist's rendering of the tower, once assembled, is shown in Figure 2.3. The location of the proposed towers is indicated on Figure 2.4 with a unique identifier 'CC##'.

Construction of the transmission line will include the completion of the following activities:

- Site preparation, including site set out, pre-clearance surveys and vegetation clearing;
- Establishment of batch plants, laydowns and offices;
- Installation of gates, grids, clean-down bays and access tracks;
- Tower site benching;
- Foundation excavation and installation;
- Establishment of brake and winch sites;
- Structure assembly and erection using a large mobile crane; and,
- Wire Stringing.

2.1.1 Wire Stringing

Conductor and earth wire stringing will be carried out as either conventional or aerial stringing. The methodology is determined by several factors that will be defined during the detailed design phase. Regardless of the method adopted, all disturbed areas that do accommodate permanent infrastructure will be reinstated progressively during construction. The short-term goal of reinstatement is to stabilise soils, provide a suitable matrix for vegetation establishment, and prevent erosion and sediment generation.

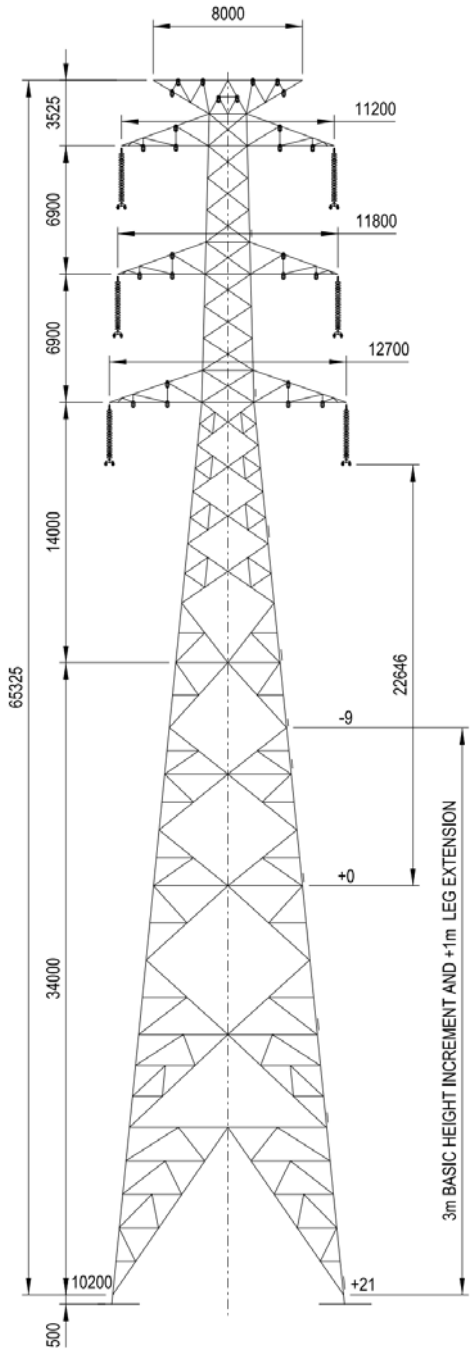

PRINCIPAL STRUCTURE DIMENSIONS
NOT TO SCALE

Figure 2.1 Indicative general arrangement of tower

Source: Powerlink

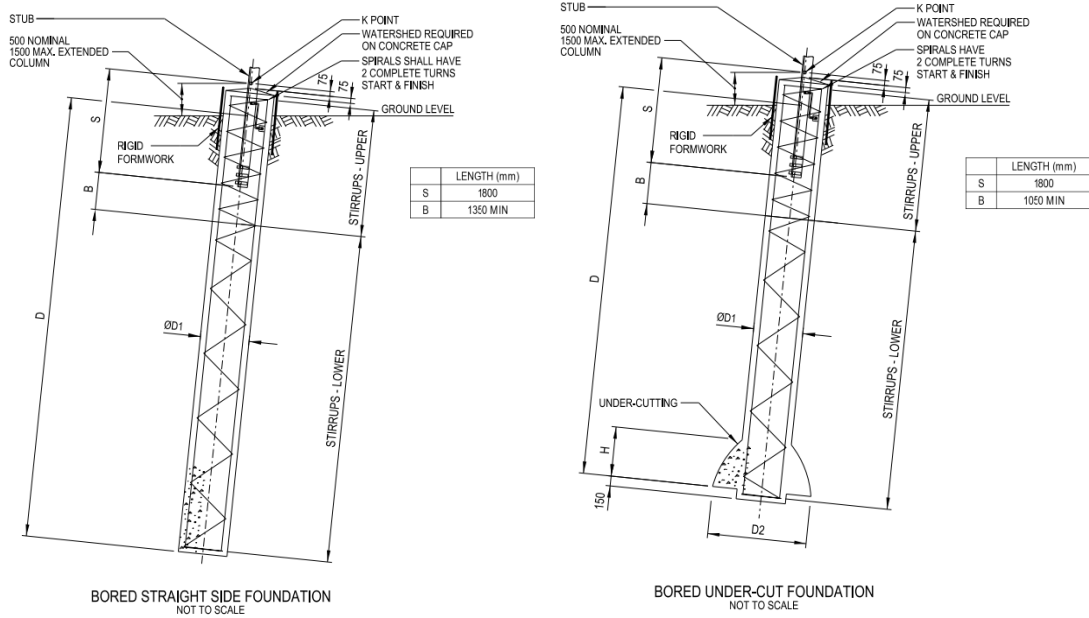

Figure 2.2 Indicative typical detail of bored pile arrangements

Source: Powerlink



Figure 2.3 Artist impression looking towards Tower CC183

Source: Powerlink (314876E, 7360988S EPSG:7856)

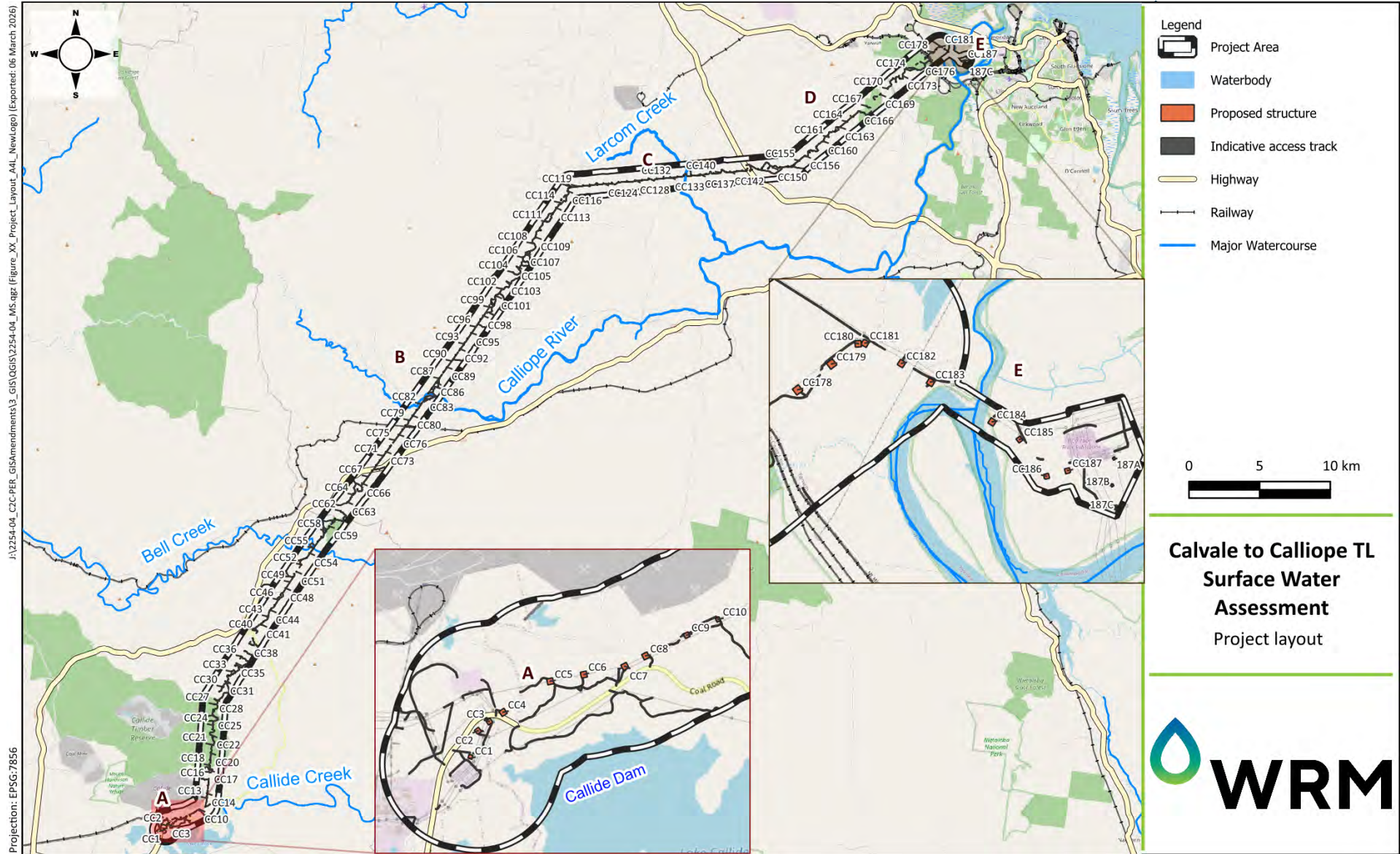

Figure 2.4 Location of proposed tower sites

2.2 CONSTRUCTION ACTIVITIES AND TIMELINE

This section provides an overview of the activities that will affect surface water in the Project Area. These are activities considered likely during the construction phase of the transmission line and associated infrastructure.

2.2.1 Disturbance footprint

Within the Project Area, a Disturbance Footprint was determined, including areas where clearing is required and temporary disturbance areas. The Disturbance Footprint was designed to avoid and minimise environmental, social and engineering constraints in the immediate vicinity of the Project, including wetlands and waterways, proximity to any road or railway corridors, slope and constructability constraints, and landholders' ongoing usage requirements.

2.2.2 Proposed timeframes

Construction is expected to commence in mid-2026, with an anticipated completion date of December 2028. The construction phase of the Project is expected to be around 30 months.

2.2.3 Hardstand areas

A range of hardstand areas may be required, including construction compounds and operation and maintenance facilities. The construction of hardstand areas will vary depending on localised ground conditions. Conditions impacting construction depend on specific existing vegetation, localised topography, the nature of the topsoil, ground moisture levels, and the geotechnical base.

2.2.4 Access tracks

The construction of access tracks will vary depending on localised ground conditions. Conditions impacting construction include existing vegetation, localised topography, the nature of the topsoil, ground moisture levels, and the geotechnical base.

2.2.5 Foundation Installation

The construction of tower foundations usually consists of the following steps:

- Setting out to mark the location of the excavation;
- Excavation/boring;
- Leg stub/base set-up;
- Placement of reinforcing steel/concreting;
- Concreting of excavated foundations; and
- Installation of earthing.

Bored foundations, see Figure 2.2, are excavated using specialised piling equipment, such as track-mounted drill rigs. Depending on the geology of the surrounding soil, foundations are typically excavated to a depth of approximately four to twelve metres. If suitable, the excavated material or imported fill is used to backfill mass concrete foundations. Surplus material is spread evenly about the site or removed, depending on quantity and suitability.

2.3 OPERATION AND MAINTENANCE

Powerlink aims to commence operations by the end of 2028, ensuring continued supply to the Gladstone region following the scheduled closure of the coal-fired Gladstone Power Station in 2029. Typically, the operational life of a transmission line and substation is 50 years. During the asset's operational life, maintenance activities will be undertaken in accordance with Powerlink's EMP and EWP.

2.4 PROJECT DESIGN STANDARDS

A detailed design and environmental assessment are necessary to evaluate the likely impacts of the Project. The detailed design may be revised as further refinements to the transmission line are made. The use of micrositing could result in minor modifications to the Disturbance Footprint. The actual Disturbance Footprints might be adjusted to reduce impacts on ecological and heritage values.

2.5 ACCESS REQUIREMENTS

Existing access tracks are proposed to be utilised for the majority of the alignment, with new access tracks created where necessary. The Project Area spans various environments and terrains, primarily rural land used for grazing. The Project Area will traverse State Forest and Conservation Park areas. The Calliope River Substation is located within the Great Barrier Reef World Heritage Area, Great Barrier Reef National Heritage List and GBRMP.

3 LEGISLATIVE AND POLICY FRAMEWORK

3.1 OVERVIEW

This section describes the regulatory framework (legislation, policies, and standards) at the Commonwealth level that would apply to surface water management for The Project. In undertaking these assessments, the key relevant Acts include:

- *Environment Protection and Biodiversity Conservation Act 1999* (EPBC Act) (*Cth*) referral
 - Submission of a Public Environment Report (PER) for assessment of significant impacts on Matters of National Environmental Significance (MNES)

At the State level, the Project is seeking a Ministerial Infrastructure Designation (MID) under the *Planning Act 2016* (Planning Act). Other relevant State legislation, relevant to surface water aspects, is as follows:

- *Water Act 2000* (Water Act)
 - Water Regulation 2016
- *Environmental Protection Act 1994* (EP Act)
 - *Environmental Protection (Water and Wetland Biodiversity) Policy 2019* (EPP Water)

3.2 COMMONWEALTH POLICY AND GUIDELINES

The Project has been referred under the EPBC Act, and is defined as:

- Building a new 275kV high-capacity double circuit transmission line between Calvale and Calliope River substations (Sections A – E); and,
- Expanding the Calliope River Substation to potentially include components such as reactors, transformers, synchronous condensers and static synchronous compensation, as well as expanding the existing 132 kV and 275 kV switching yards.

The referral occurred on 6 January 2025. On 4 February 2025, a delegate of the Minister determined the Project to be a controlled action due to likely significant impacts on the following MNES that are protected under Part 3 of the EPBC Act, and the following controlling provisions apply to the Project due to its potential impact on:

- Listed threatened species and communities (sections 18 and 18A)
- The world heritage values of a declared World Heritage property (sections 12 and 15A)
- The national heritage values of a National Heritage place (sections 15B and 15C)
- The environment in the Great Barrier Reef Marine Park (sections 24B and 24C).

3.2.1 MNES Significant Impact Guidelines

The purpose of the MNES Significant Impact Guidelines (the MNES guidelines) is to assist any person who proposes to take an action to decide whether or not they should submit a referral to the Australian Government Department of Climate Change, Energy, the Environment and Water (the Department) for a decision by the Australian Government Environment Minister (the Minister) on whether assessment and approval is required under the EPBC Act. An action requires the Minister's approval if it has, will have, or is likely to have a significant impact on an MNES. The guidelines outline a 'self-assessment' process, including detailed criteria, to help individuals determine whether a referral may be required.

The following is a summary of the relevant aspects and associated detailed criteria that highlight the significant impacts under the Guidelines.

World Heritage properties with natural heritage values

The Project's transmission line and substation expansion construction activities will be undertaken on land within the Great Barrier Reef (GBR) World Heritage Area (WHA) (Calliope River Island).

The Project involves construction activities upstream of the GBR WHA, with the Project Area crossing waterways at several locations.

An action is likely to have a significant impact on the natural heritage values of a World Heritage property if there is a real chance or possibility that the action will:

- Modify, alter or inhibit landscape processes, for example, by accelerating or increasing susceptibility to erosion, or stabilising mobile landforms, such as sand dunes, in a World Heritage property;
- Divert, impound or channelise a river, wetland or other water body in a World Heritage property;
- Substantially increase concentrations of suspended sediment, nutrients, heavy metals, hydrocarbons, or other pollutants or substances in a river, wetland or water body in a World Heritage property; and,
- Introduce noise, odours, pollutants or other intrusive elements with substantial, long-term or permanent impacts on relevant values.

National Heritage places with natural heritage values

The Project's transmission line and substation expansion construction activities will be undertaken on land recorded on the National Heritage List (NHL) (Calliope River Island). Construction activities will occur upstream of the NHL, with the Project Area crossing waterways at several locations.

An action is likely to have a significant impact on the natural heritage values of a National Heritage place if there is a real chance or possibility that the action will:

- Modify, alter or inhibit landscape processes, for example, by accelerating or increasing susceptibility to erosion, or stabilising mobile landforms, such as sand dunes in a National Heritage place;
- Divert, impound or channelise a river, wetland or other water body in a National Heritage place;
- Substantially increase concentrations of suspended sediment, nutrients, heavy metals, hydrocarbons, or other pollutants or substances in a river, wetland or water body in a National Heritage place; permanently damage or obscure rock art or other cultural or ceremonial features with World Heritage values; or,
- Introduce noise, odours, pollutants or other intrusive elements with substantial and/or long-term impacts on relevant values.

Great Barrier Reef Marine Park

The Project's transmission line and substation expansion will be undertaken on land located upstream of the Great Barrier Reef Marine Park (GBRMP). The PER guidelines focus on the Project's water quality impacts on the GBRMP.

An action is likely to have a significant impact on the environment of the GBRMP if there is a real chance or possibility that the action will:

- Result in a substantial change in air quality or water quality (including temperature) which may adversely impact on biodiversity, ecological health or integrity or social amenity or human health; or,
- Result in persistent organic chemicals, heavy metals, or other potentially harmful chemicals accumulating in the marine environment such that biodiversity, ecological integrity, or social amenity or human health may be adversely affected.

4 EXISTING SURFACE WATER ENVIRONMENT

4.1 OVERVIEW

Extending for 87 kilometres from the Calvale Substation to the Calliope River Substation, the Project Area crosses two LGAs: BSC and GRC. The Project Area features a mix of modified and natural environments, with varying land uses along the alignment, including existing linear infrastructure such as transmission lines, transport corridors, and gas pipelines, as well as grazing and conservation areas.

The existing land uses and activities characterise the Project Area:

- Section A: Grazing, recreational uses, conservation, natural environments and Callide Dam, Callide Power Station, Calvale substation and associated transmission infrastructure;
- Section B: Grazing, production forestry, Dawson Highway, Moura System railway corridor, gas pipelines, plantation forestry and conservation. One existing Powerlink 275 kV transmission line;
- Section C: Grazing, Bruce Highway, gas pipelines and telecommunications. Two existing Powerlink 275 kV transmission lines;
- Section D: Grazing, production forestry, rural residential, conservation, and North Coast railway corridor. One existing Powerlink 275 kV Calliope River transmission line;
- Section E: Conservation, port activities (coal conveyor belt), Calliope River Substation and associated transmission infrastructure.

The Project Area and its surroundings are mainly designated as ‘Rural’ according to the Gladstone Regional Planning Scheme and the Banana Shire Planning Scheme. The land use objectives for ‘Rural’ are consistent across both planning schemes, acknowledging a variety of rural activities, including agriculture, and emphasising the importance of preserving the rural character and amenity of the area.

Certain portions of Section A fall within the Community Facilities Zone as per the Banana Shire Planning Scheme, while parts of Sections D and E are classified within the Special Purpose Zone, Environmental Management Zone, Conservation Zone, and Open Space Zone according to the Gladstone Regional Planning Scheme. Additionally, Sections D and E are situated within the Gladstone State Development Area (SDA), which includes precincts for port-related industry, environmental management, and high-impact industry. Sections B and C also overlap with the Callide Infrastructure Corridor SDA.

No amendments to the current zoning of the Project Area are planned to facilitate the Project. Powerlink intends to use the MID process under the Planning Act to secure the necessary land use approval for the Project.

Downstream of the project, existing industrial and port land uses are located, including:

- Queensland Alumina Refinery (QAL);
- Boyne Smelters Limited;
- Three LNG plants (Gladstone LNG, Australia Pacific LNG, Queensland Curtis LNG Cement Australia Plant);
- Yarwun Alumina Refinery;
- Wiggins Island and RG Tanna Coal Terminals;

- Recreational and tourism uses, including the Gladstone Marina, East Shores Playground and Heron Island Boat Transfer Terminal; and
- Extensive capital and maintenance dredging – a total of 297,688 m3 of material was dredged from 10 November 2024 to 13 December 2024 (TMR, 2025)

4.2 CLIMATE

4.2.1 Overview

Located on the central coast, south of the Tropic of Capricorn, the Project Area experiences a subtropical climate with significant summer rainfall, predominantly between December and March. Rainfall ranges from low to moderate in the coastal plains, increasing to moderate to high in the steeper ranges due to orographic influences.

According to the Köppen Classification system, as outlined by the Bureau of Meteorology of Australia (BoM), the climate of the Project Area falls within the moderately dry winter subtropical zone. Rainfall is seasonally distributed, characterised by a wet season from October to March and a drier season from April to September.

4.2.2 Rainfall

Daily rainfall records have been maintained since 1922 at Voewood (Station No. 39233), which is located southwest of the Project Area, shown on Figure 1.1. Rainfall data recorded at this station is considered representative of rainfall likely to fall in the vicinity of the Project Area. Table 4.1 shows summary details of the rainfall stations, including the dates on which each was operated. The highest annual rainfall at this station (1,588 mm) was estimated as being the 1892/93 water year, as shown on Figure 4.3. During the 1974 water year, an annual total of 1,408 mm was recorded, approximately double the median annual rainfall total of 786 mm.

Table 4.1 Weather stations

Station No.	Station Name	Latitude	Longitude	Elevation (mAHD)	Opened	Closed
39125	Mount Alma	24.02	150.87	99	1960	2006
39020	Calliope Station	24.02	150.97	58	1906	2016
39233	Voewood	24.12	150.82	n/a	1913	1978
39249	Wyalla	24.12	150.76	200	1959	2000

Synthetic historical rainfall and evaporation data for the Mount Alma gauge from the SILO Data Drill service (QLD, 2023) were adopted to describe the rainfall variability of the Project Area, see Figure 4.1. The key advantage of adopting the Data Drill dataset is that it has been adjusted to remove accumulated totals across multiple days and to fill rainfall gaps using data from nearby stations.

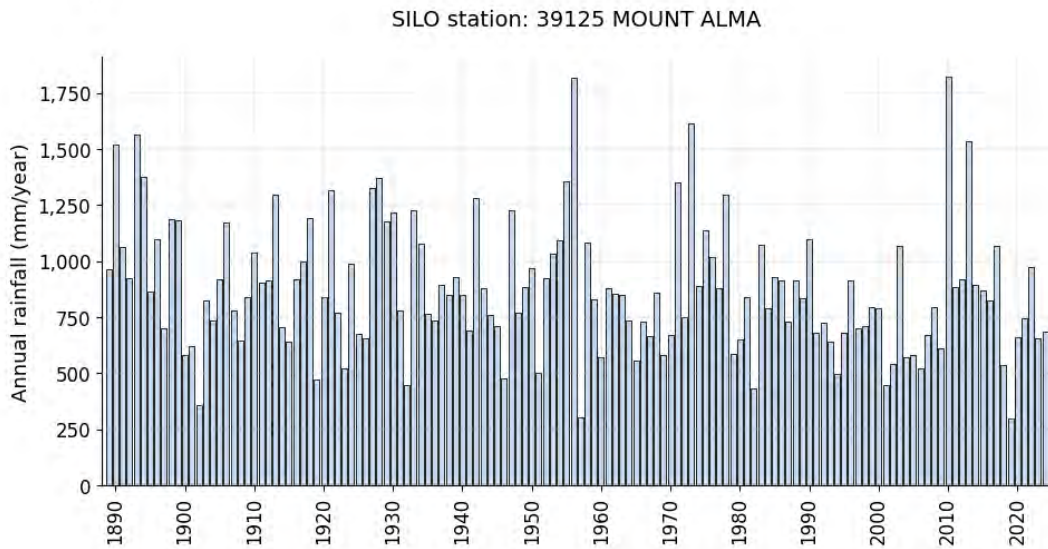

Figure 4.1 Annual total rainfall from synthetic daily rainfall data at the Project Area

Figure 4.2 shows summary rainfall statistics, with the highest monthly rainfalls occurring in January and February. Evaporation peaks between November and January (inclusive). The upper panel of Figure 4.3 indicates that significant rainfall can occur throughout the year, with a notable monthly total in December 1973.

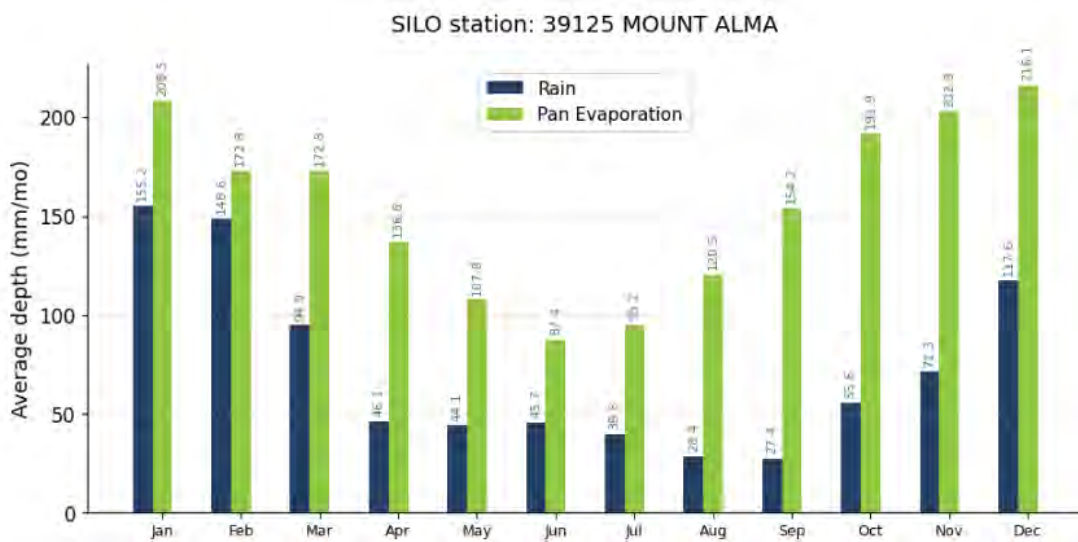

Figure 4.2 Distribution of monthly rainfall and pan evaporation

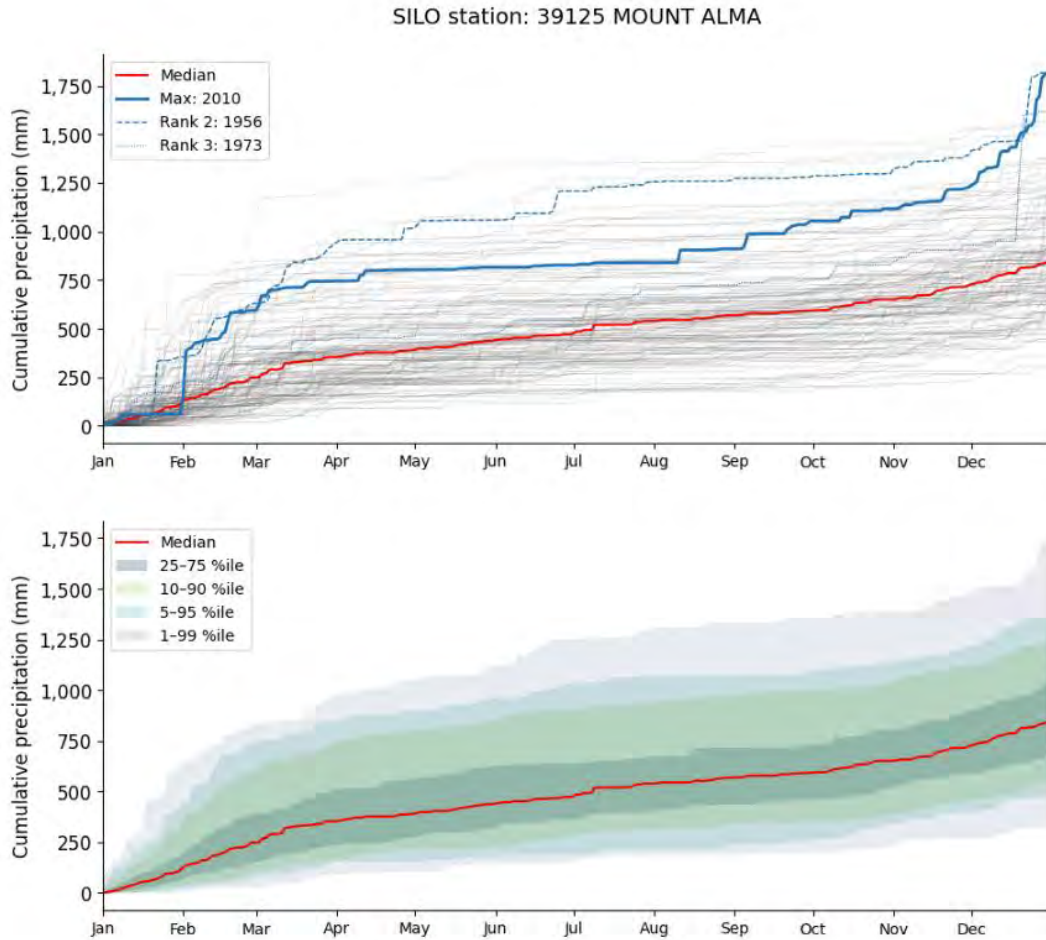

Figure 4.3 Time series of rainfall near the Project Area

4.3 TOPOGRAPHY AND DRAINAGE

Multiple waterways cross the Project Area, with the largest being the Calliope River in Section E, which flows into the Port of Gladstone and then into the GBRMP. These waterways show signs of disturbance, erosion, and weed growth. The Calliope River, originating near Cedric Mountain in the Don River State Forest, meanders for almost 100 kilometres before reaching the Pacific Ocean near Gladstone. The Calliope River runs parallel to the Project Area, as shown on Figure 1.1.

The Mount Larcom Range confines this broader region to the east, and the Calliope Range to the west geographically. The Calliope River basin’s catchment area covers 1,890 km², the total Project Area within this catchment is only 97 km², making up approximately 5% of the catchment area. It collects water from important tributaries such as Oakey Creek and Larcom Creek, with Larcom Creek being the longest contributing creek, draining about 270 km² through Section C. Bell Creek intersects near the southern end of Section B and flows west of the Project Area, opposite the Calliope River. Bell Creek is within the Dawson River basin’s catchment, which spans 50,776 km².

A modified lake wetland is mapped near Boyles Road, accompanied by natural river wetlands near Mount Alma Road and Fig Tree Road. A natural swamp wetland is located near the Calvale Substation. At the Calliope River Substation, intertidal wetlands containing mangrove and saltpan vegetation are present. Freshwater farm dams of various sizes and water levels are scattered throughout the Project Area. Most have muddy banks with dense, low shrubs, while two feature

some fringe aquatic vegetation, including rushes and sedges. All farm dams assessed during field surveys have shallow, muddy banks and have been heavily impacted. The catchments above the Project Area lack sufficient topographic detail to enable accurate prediction of peak flows and velocities using hydraulic models. Figure 4.4 presents the available LiDAR data to develop hydraulic models.

Projection: EPSG:7856
J:\2254-04_C2C-PER_GISAmendments\3_GIS\QGIS\2254-04_MS.qgz (Figure_3_1_Topographic_data_available_to_defines_A4L_NewLogo) (Exported: 05 March 2026)

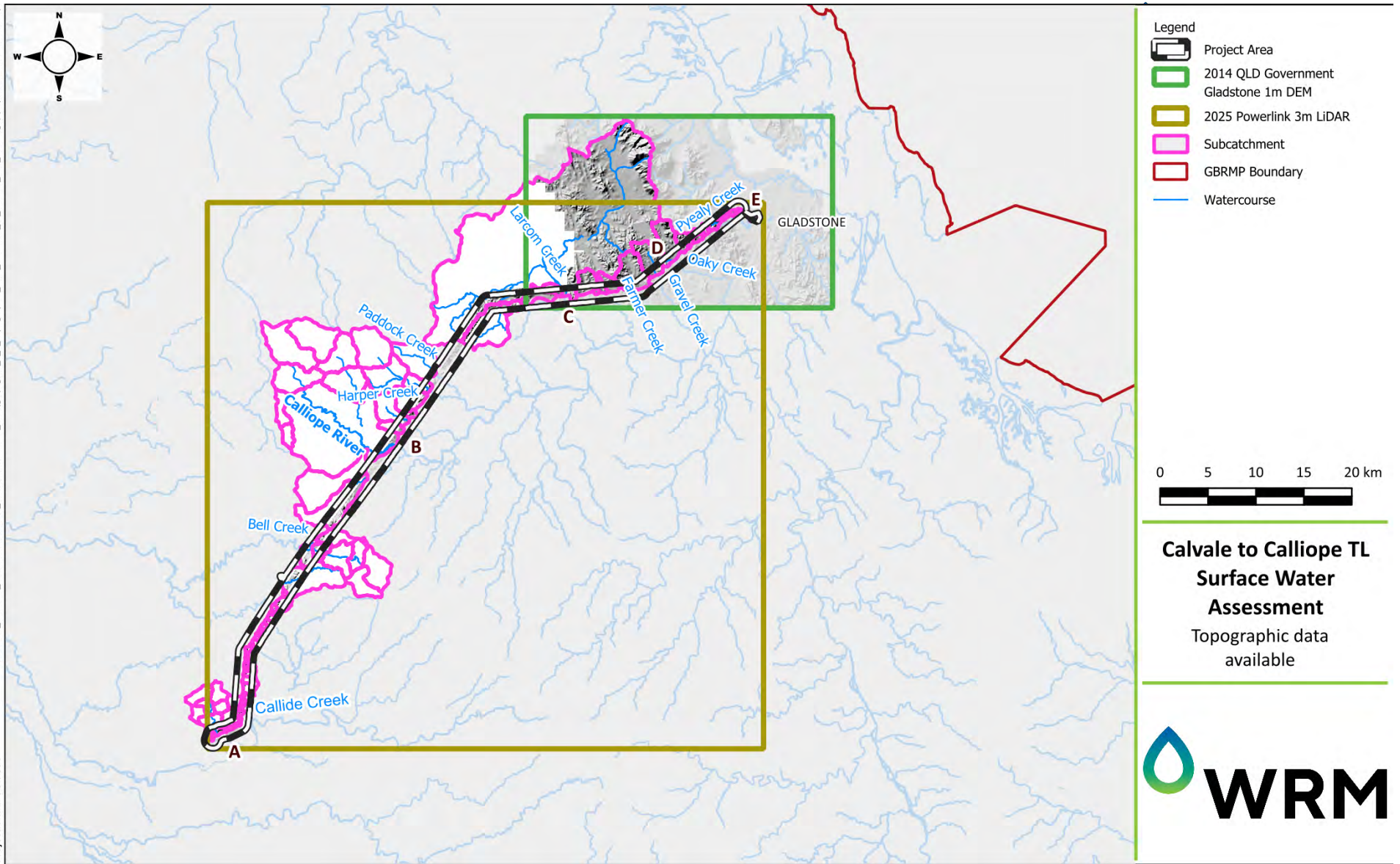

Figure 4.4 Topographic data available

4.3.1 Water Bodies and Waterway Classifications

A GIS dataset identifying the stream order data for the watercourses in the Project Area was available from the Queensland Spatial Catalogue (QSpatial). This dataset was based on Geoscience Australia's drainage network of Queensland, where streams are connected and ordered according to the Strahler method (DNMRE, 2010). Strahler stream order is shown on Figure 4.5 through Figure 4.7.

The Project Area crosses *unmapped watercourses* and drainage features, as defined by the Water Act. Numerous *drainage features* are mapped and crossed by Section D. The Water Act predominantly identifies a series of first-order streams near the Project Area that are designated as *unmapped watercourses*, as shown on Figure 4.8 through Figure 4.10. Farmer Creek, Calliope River and an unnamed tributary of Callide Creek at Section A are mapped as defined *watercourses*. Notably, Larcom Creek is a fourth-order stream at the point where it flows through the Project Area. However, the Water Act does not define Larcom Creek as a *watercourse*. It is only further downstream (about two kilometres) of Section C of the Project Area that Larcom Creek is then defined as a *watercourse*.

The Calliope River basin's current ecological state reflects a balance between human impact and natural resilience. While the basin has witnessed considerable clearing of native vegetation, estimated at up to two-thirds, riparian zones comprising native flora still exist along major creeks. This riparian vegetation plays a vital role in maintaining in-stream water quality, providing some protection against the impacts of grazing, cropping, and industrial activities within the catchment. Downstream, the Calliope River basin interacts with industrialised and port land uses as well as intensive dredging activities primarily within and around the Gladstone Harbour region.

Within the Project Area, streams that are significant to native fish habitat, fish migration and passage are mapped on Figure 4.11 through to Figure 4.13. The importance of a stream and potential impact to fish passage from works within the stream are colour-coded:

- Grey – Major risk (tidal)
- Purple – Major risk
- Red – High risk
- Amber – Moderate risk
- Green – Low risk

The Calliope River's flow regime is freshwater until the Bruce Highway, where a weir is located, and the system transitions to a tidally influenced estuary that discharges into the harbour. As mapped, Section E of the Project interacts within the tidal extent, a Major risk waterway. Section D crosses two High impact waterways. Section C crosses one Major risk and three high risk waterways. Section B crosses two major risk and five high risk waterways. Section A includes one high risk waterway. Where any construction works are necessary near watercourses, they will be conducted in accordance with the Accepted Development Requirements for operational work that is constructing or raising waterway barrier works, September 2025 (ADR) or the October 2018 superseded ADR, which may be used up until 30 November 2026. Where compliance is not possible, relevant approvals will be obtained.

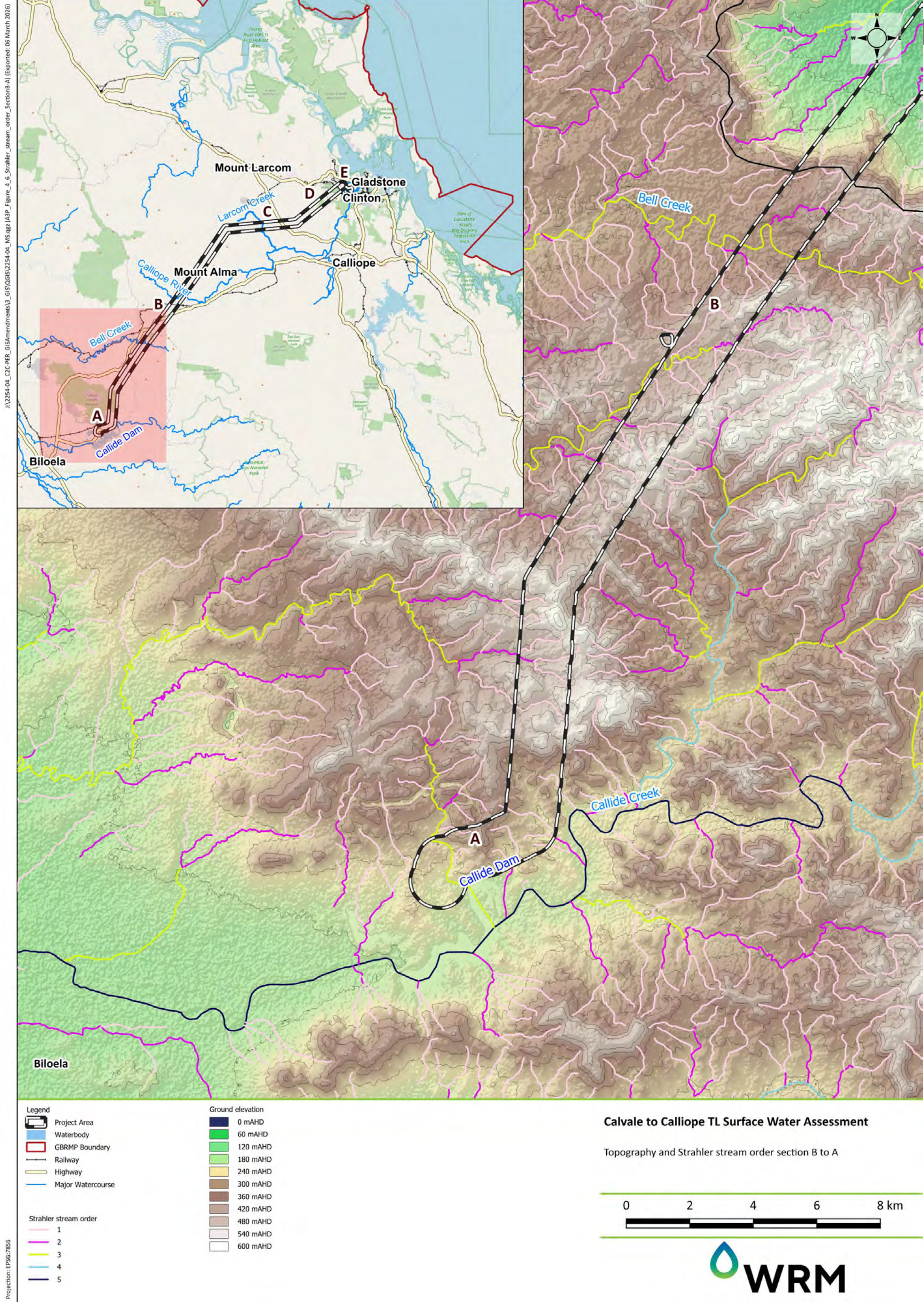

Figure 4.5 Topography and regional drainage characteristics A - B

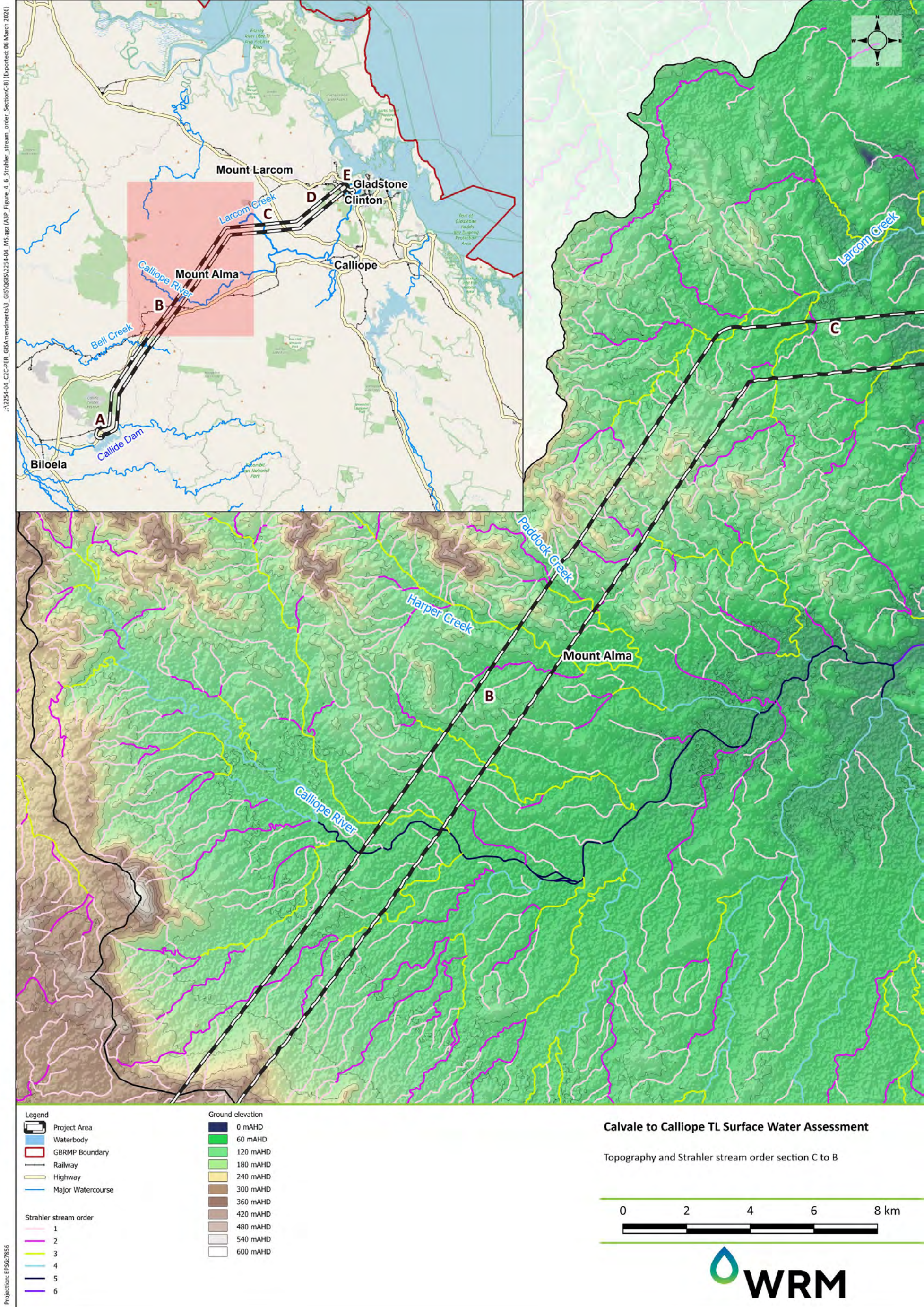

Figure 4.6 Topography and regional drainage characteristics B - C

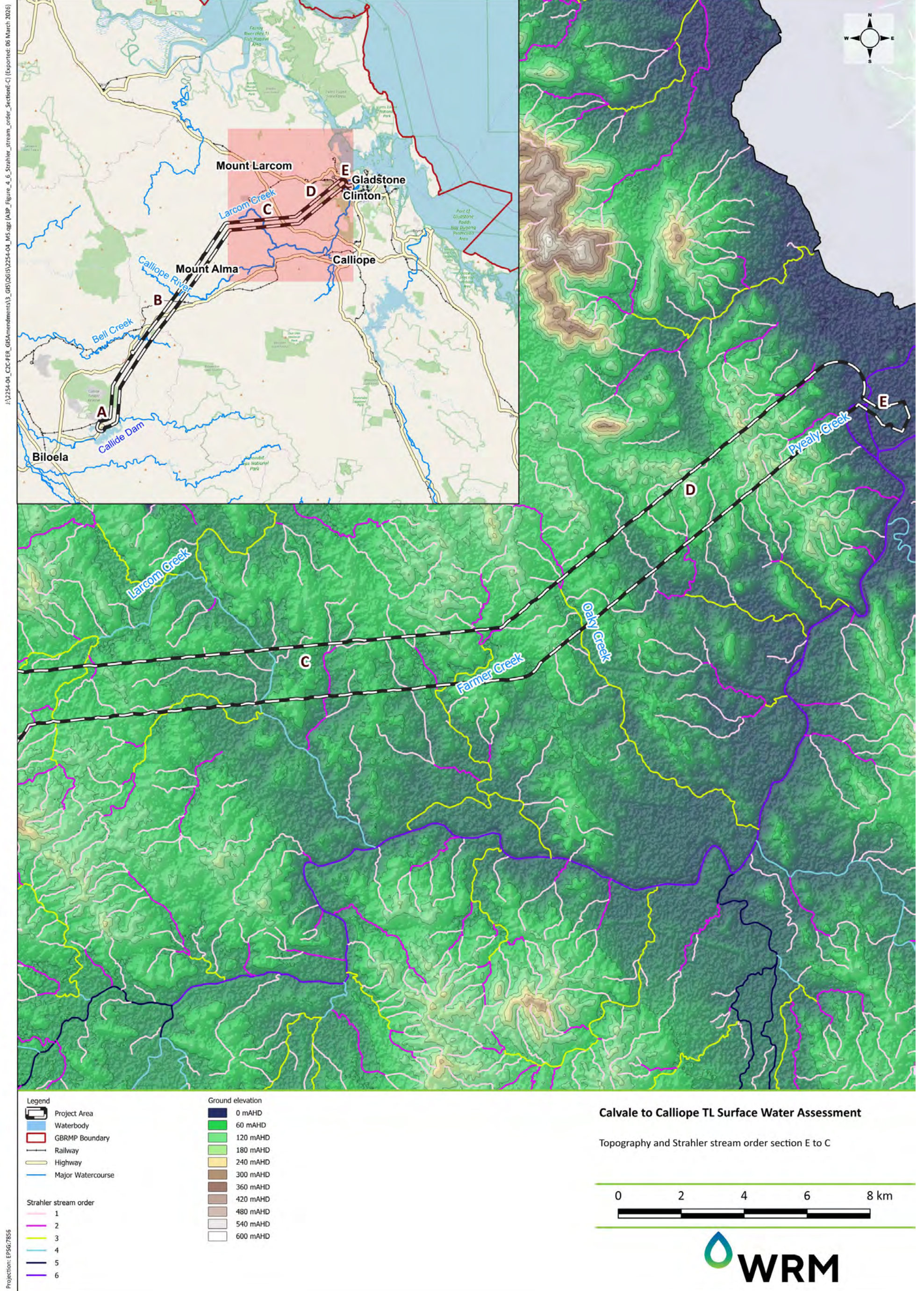

Figure 4.7 Topography and regional drainage characteristics C - E

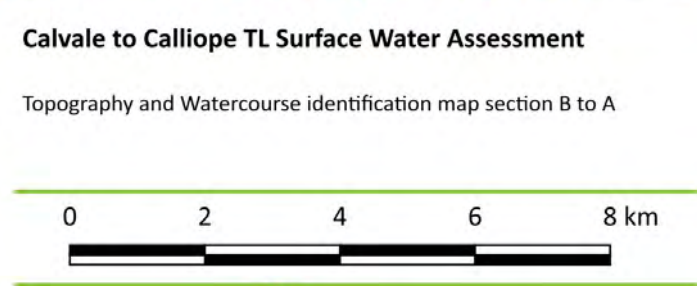
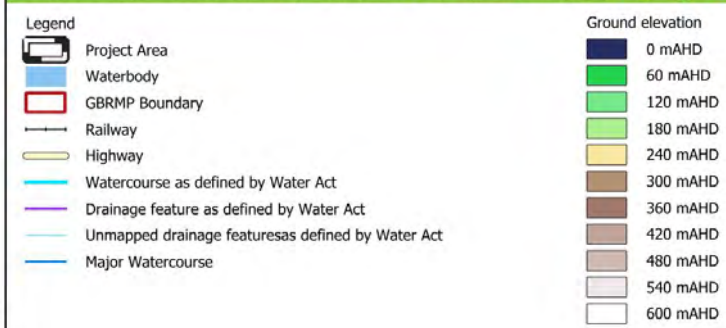
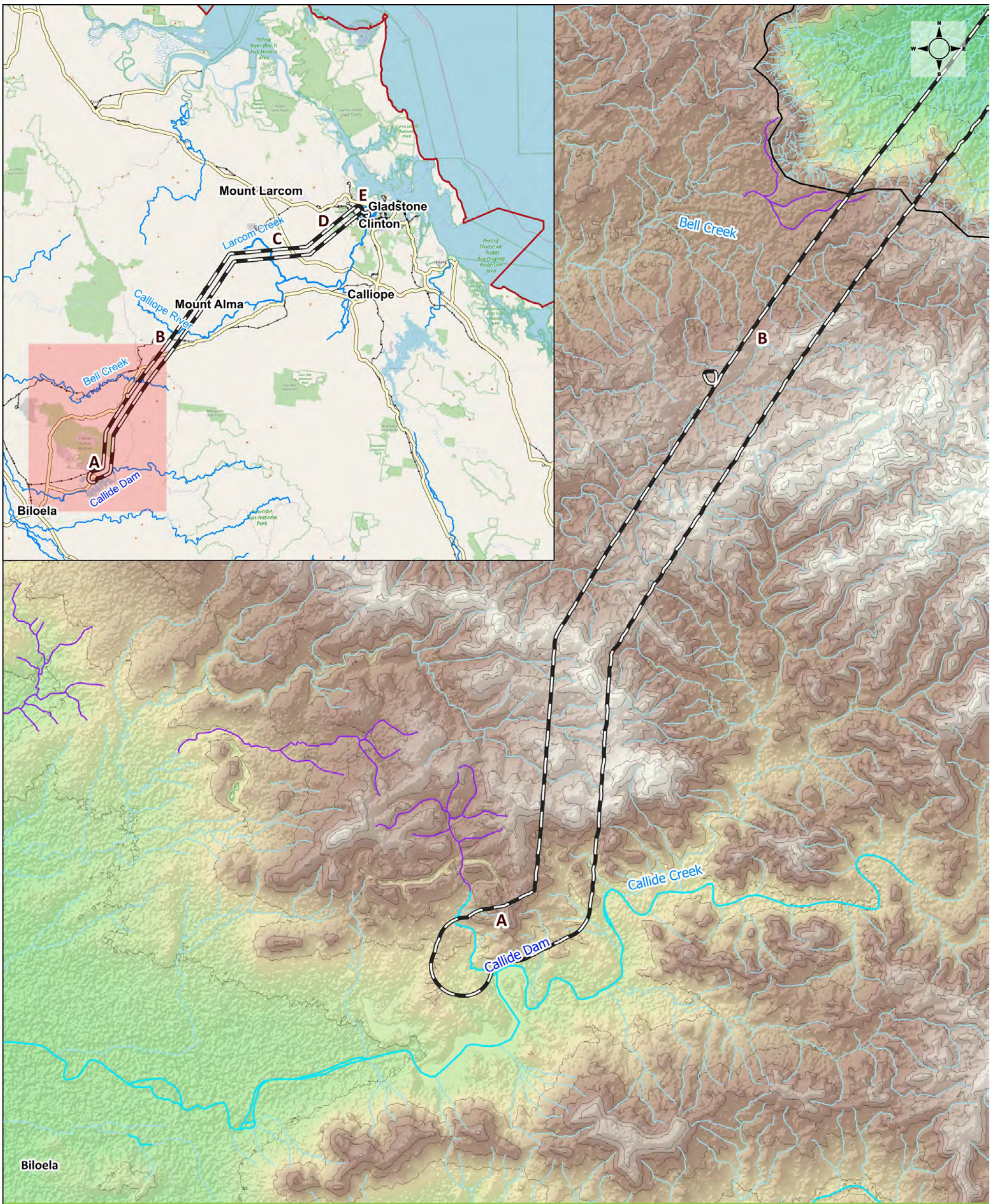

Figure 4.8 Watercourse identification map (Water Act) A - B

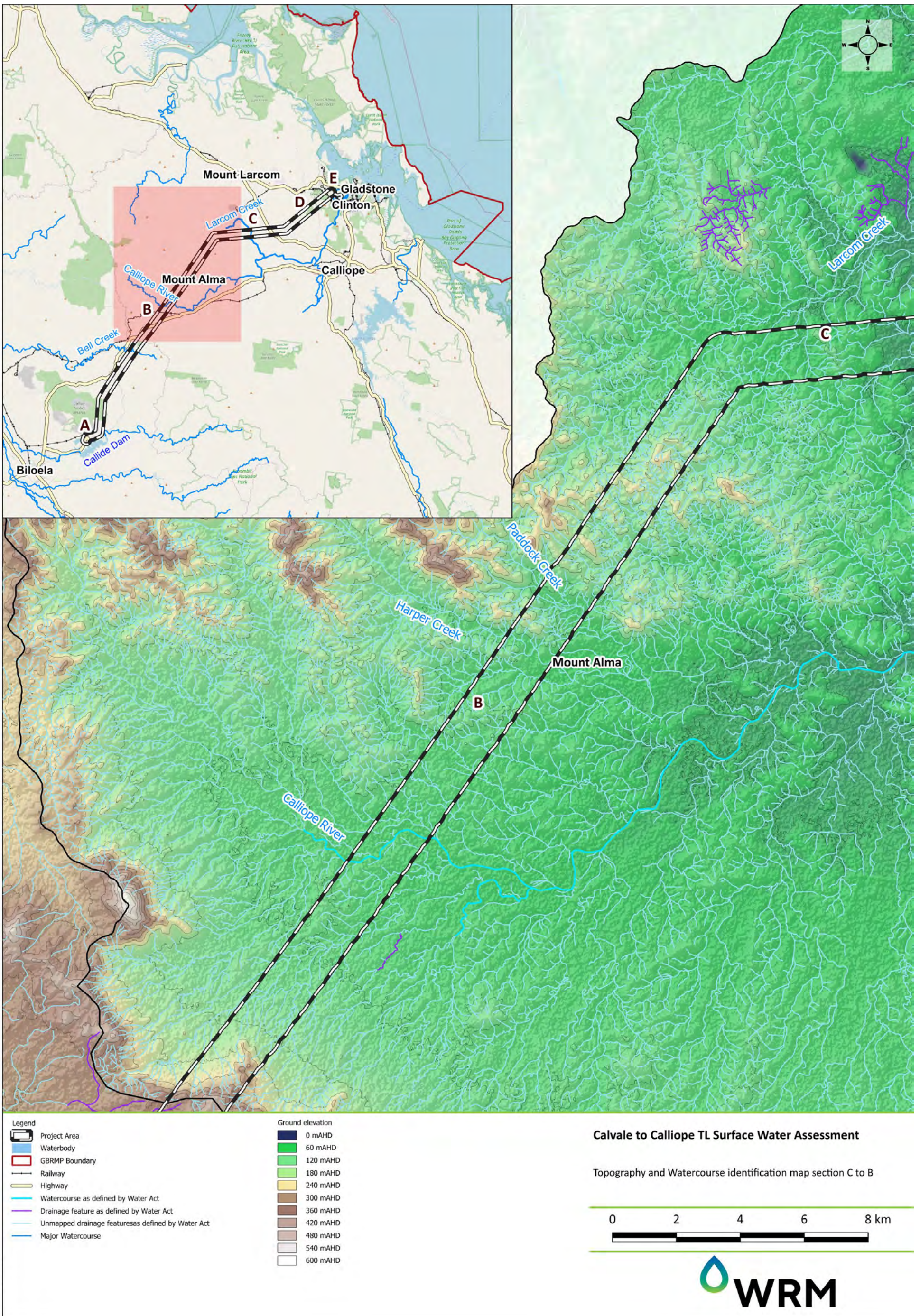

Figure 4.9 Watercourse identification map (Water Act) B - C

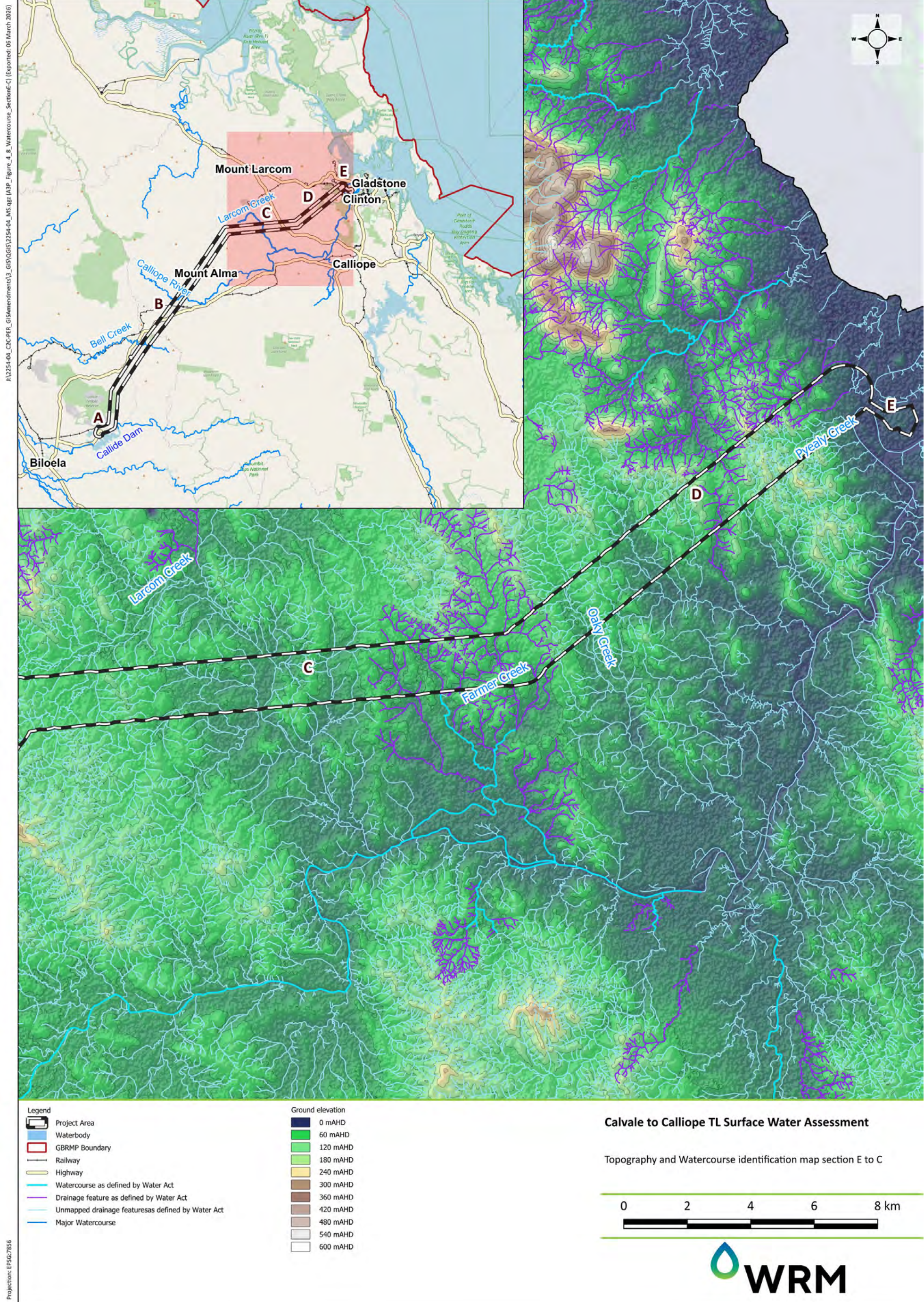

Figure 4.10 Watercourse identification map (Water Act) C - E

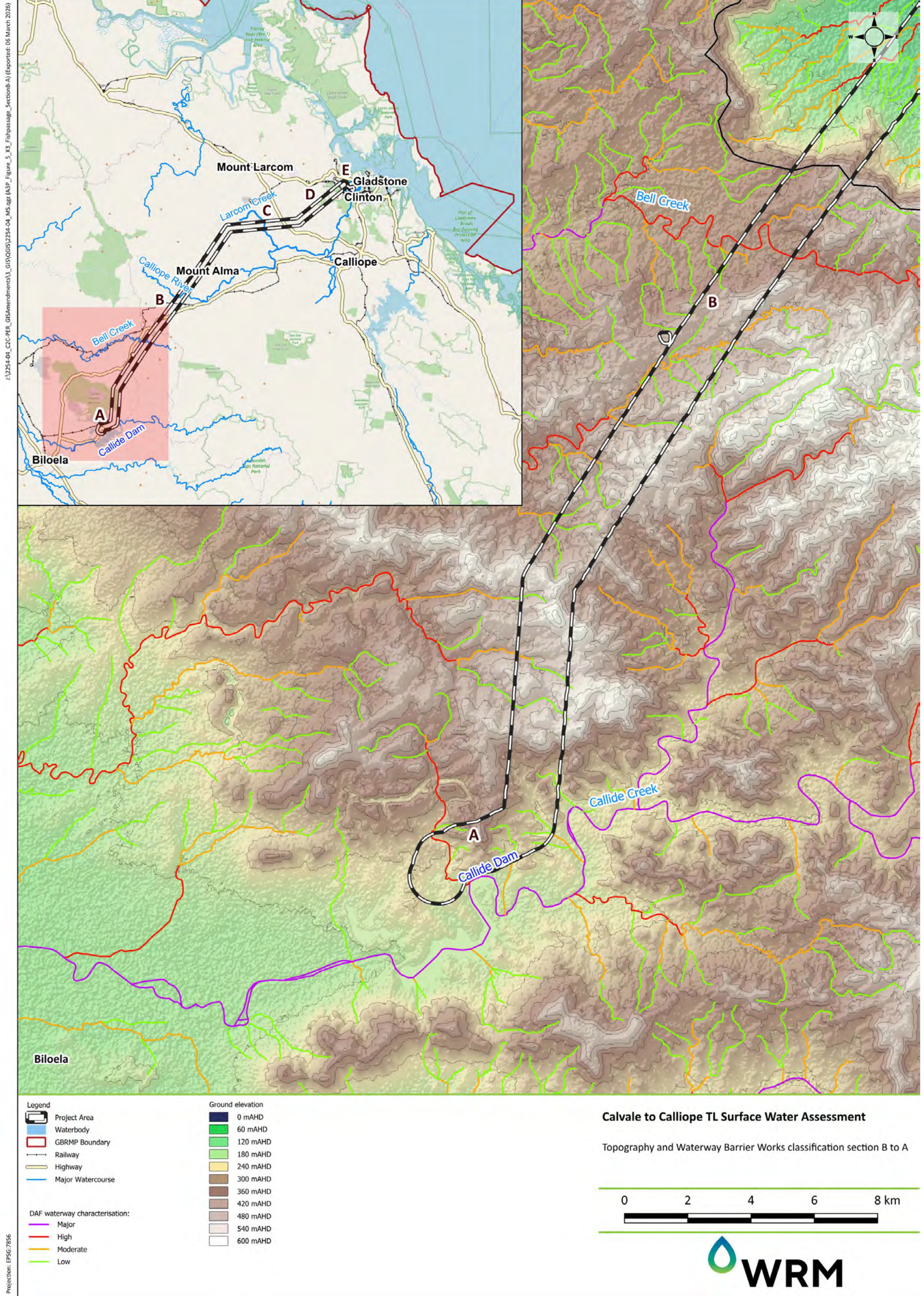

Figure 4.11 Waterway characterisation map (Waterway barrier works) A - B

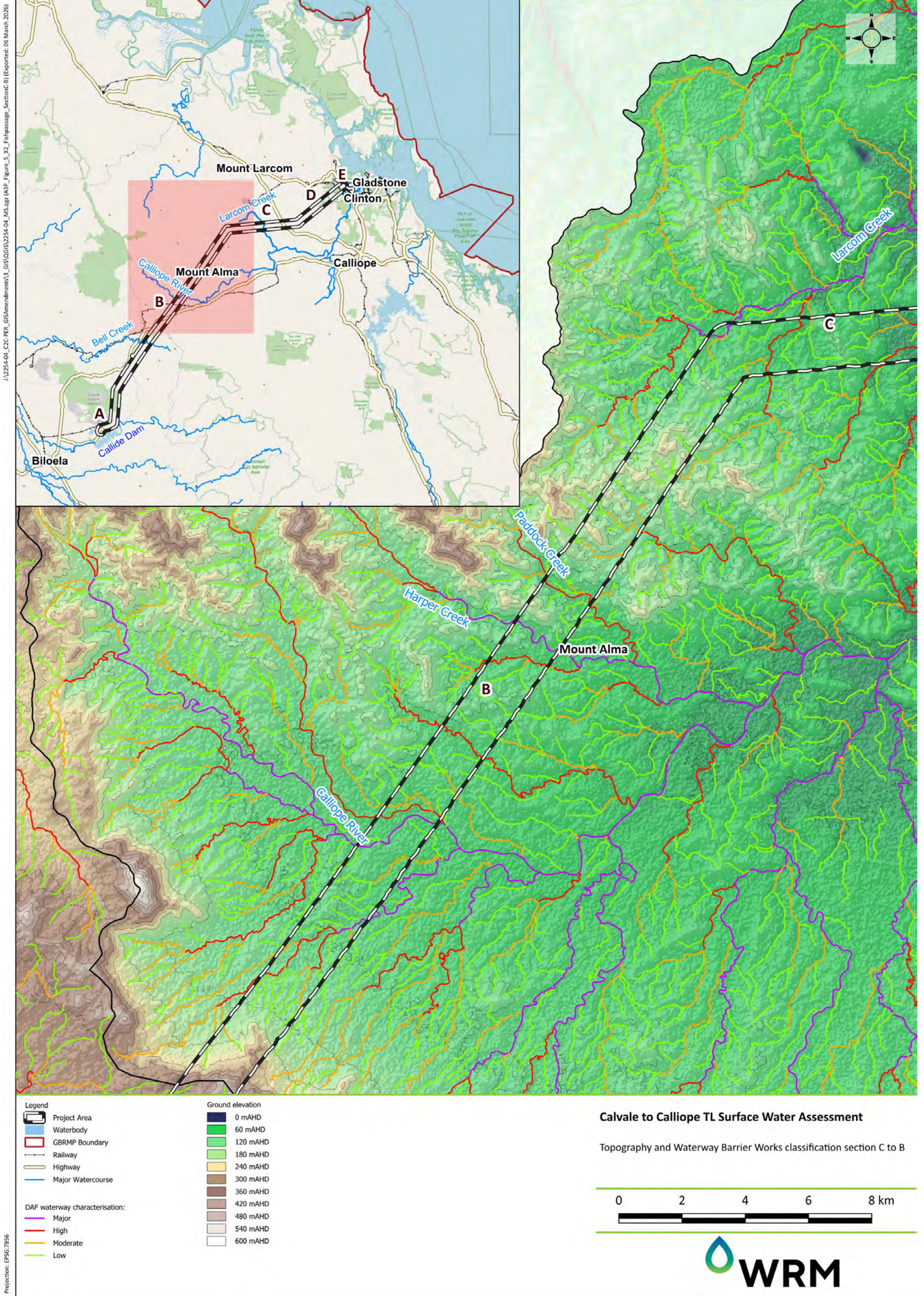

Figure 4.12 Waterway characterisation map (Waterway barrier works) B - C

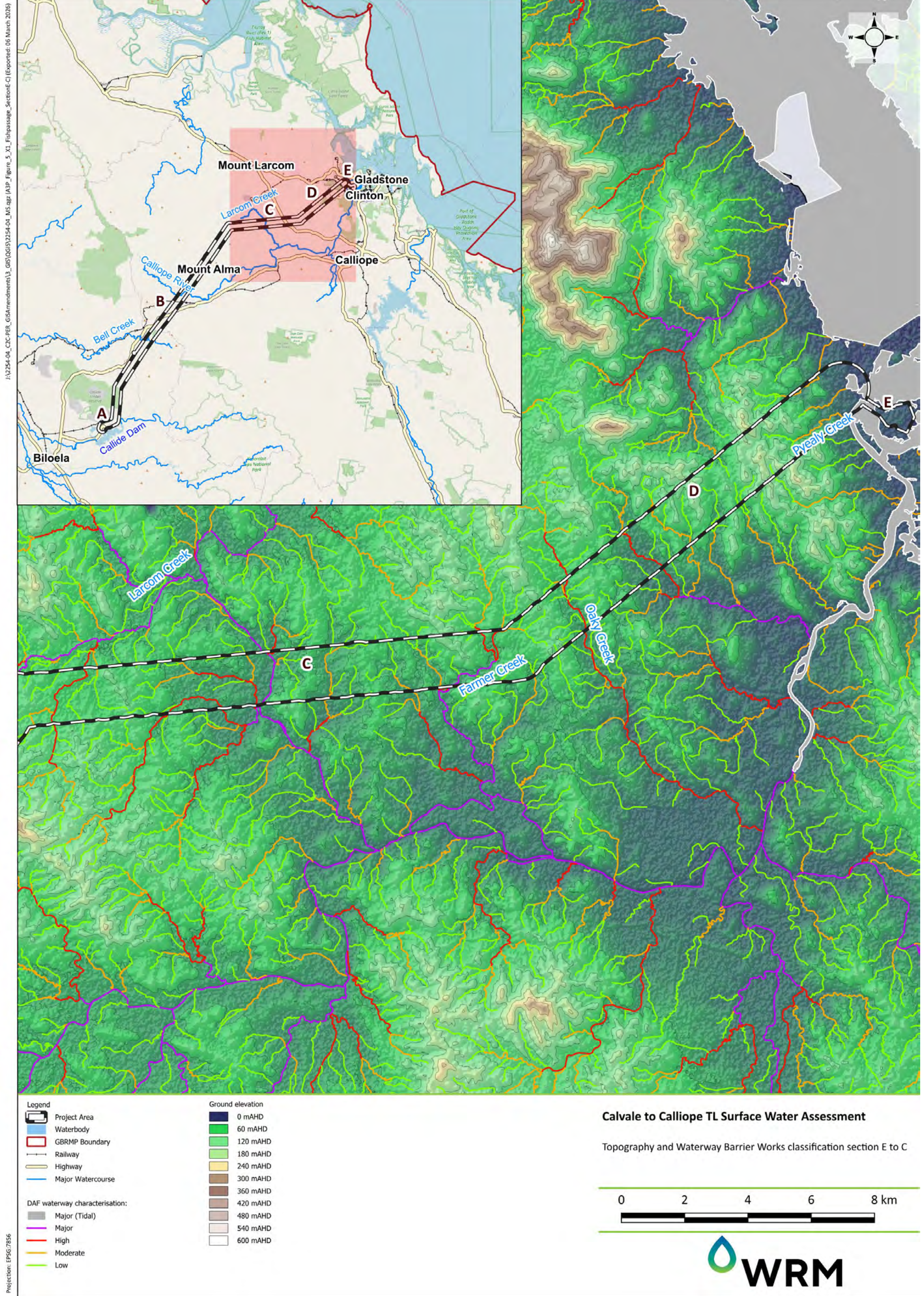

Figure 4.13 Waterway characterisation map (Waterway barrier works) C - E

4.4 FLOOD HISTORY

Figure 1.1 shows the closest active streamflow gauge to the Project Area is Castlehope (station number GS132001A), located downstream of the Project Area. The stream flows recorded at the gauge are presented in Table 4.2. The Castlehope gauge is the only streamflow gauging station currently in operation in the Calliope River basin. It was opened in 1938 and has a catchment area of 1,288 km². The Calliope River at Mount Alma gauge (132002A) operated from 1968 to 1988. It is located in the upper catchment and has a catchment area of only 165 km². While flood history was available for the Calliope River at the Castlehope gauge, this dataset provides only regionalised information on typical flood behaviour. Figure 4.14 is an analysis of the flood flows based on the Flike Bayesian fitting software. The flood frequency analysis had narrow confidence intervals, indicating acceptable convergence of flood fitting software.

Table 4.2 Calliope River at Castlehope (GS12300A) gauge peak flow events

Year	Max Flow (m ³ /s)	Year	Max Flow (m ³ /s)	Year	Max Flow (m ³ /s)	Year	Max Flow (m ³ /s)	Year	Max Flow (m ³ /s)
1940	180	1957	1,417	1974	256	1991	772	2008	21
1941	1,600	1958	2,099	1975	3,864	1992	1,912	2009	1,086
1942	47	1959	302	1976	675	1993	313	2010	366
1943	2,828	1960	172	1977	738	1994	245	2011	2,021
1944	539	1961	117	1978	1,333	1995	362	2012	1,893
1945	424	1962	632	1979	2,908	1996	7	2013	543
1946	41	1963	456	1980	450	1997	1,905	2014	3,269
1947	163	1964	1,409	1981	273	1998	396	2015	1,421
1948	4,038	1965	108	1982	1,385	1999	308	2016	2,296
1949	732	1966	3	1983	38	2000	310	2017	475
1950	2,589	1967	8	1984	1,228	2001	143	2018	1,991
1951	605	1968	72	1985	89	2002	704	2019	555
1952	494	1969	685	1986	174	2003	166	2020	2
1953	194	1970	15	1987	667	2004	2,768	2021	283
1954	521	1971	107	1988	134	2005	494	2022	112
1955	1,204	1972	2,154	1989	281	2006	155	2023	170
1956	1,527	1973	710	1990	1,200	2007	61	2024	18

n.b. Flood of record shown in bold

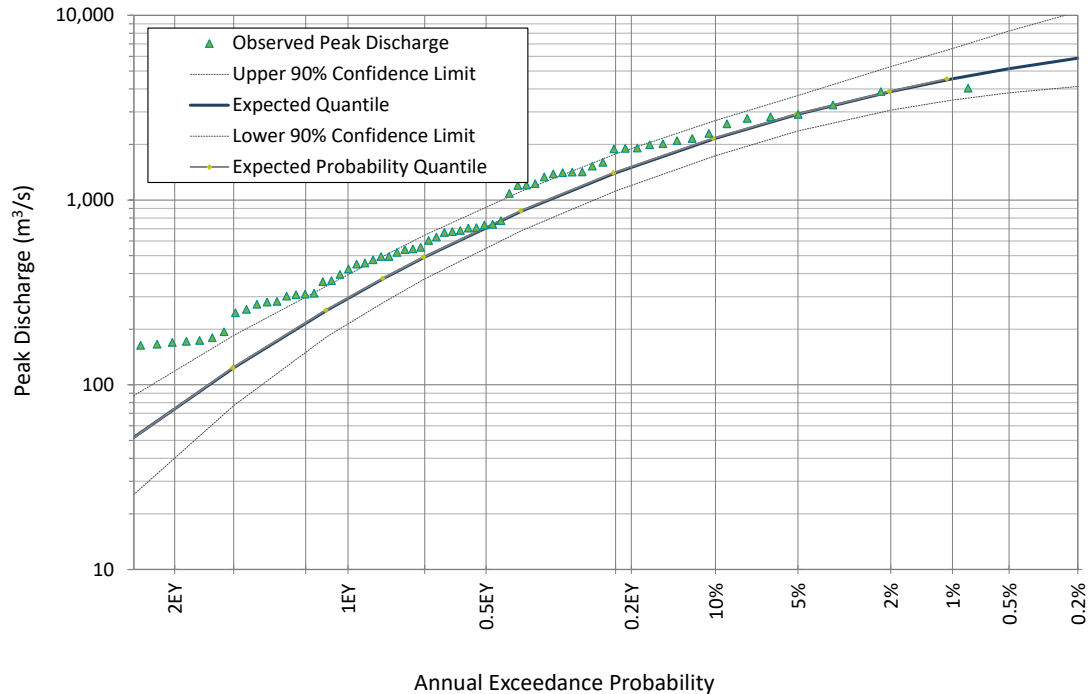

Figure 4.14 Flood frequency analysis at Calliope River at Castlehope (GS12300A)

4.5 SOIL TYPES AND CHARACTERISTICS

Land use within the Calliope River basin predominantly consists of dryland grazing, with smaller pockets dedicated to irrigated cropping and industrial activities. Water resource allocation within the basin is low and reflective of the relatively undeveloped state of the area. The estimated water consumption from the river and its tributaries primarily serves irrigation needs.

The Project Area is located in a largely rural, sparsely settled landscape, mainly used for light grazing and livestock production. The Queensland Land Use layer maps the primary land usage as production from relatively natural environments, such as grazing native vegetation. Cattle grazing is the dominant land use in the catchment, primarily confined to the coastal plains where much of the natural vegetation has been thinned or removed. At the same time, the ranges mostly retain undisturbed eucalypt forests. The Project Area contains the Callide Dam and farm dams, and the landform, though cleared of large stands of trees in places, is relatively unmodified from its original topography. Vegetation throughout the Project Area is sparse, with some significant riparian vegetation along drainage corridors.

Section E is located within a low-lying area, and acid sulfate soils are highly likely to occur. Six land parcels are identified as listed on the Contaminated Land Register (CLR) or the Environmental Management Register (EMR). Powerlink has undertaken a desktop assessment of potential contamination risks. Five sites were assessed as low risk and one as moderate risk. Management measure is to retain spoil within the same land parcel. Within Section E, the following land parcels are on EMR:

- 1, 2 and 3 SP338512, registered on EMR for activities relating to Yarwun Alumina Refinery (tower sites CC178-182 traverses through these lots).
- Lot 113 CTN799 Calliope River substation.

Figure 4.15 shows the land classification according to the Queensland Government's agricultural land types within the Project Area, namely:

- Crop land (A1);
- Crop land – horticulture only (A2);
- Pastureland – sown pastures and native pastures on high fertility soils (C1);
- Pastureland – native pastures (C2);
- Pastureland – native pastures, light grazing in accessible areas (C3); and,
- Non-agricultural land (D).

The Project Area is mapped as having predominant Dermosol soil from Section C to E, Rudosol from Section A to B, and Sodosol in Section A, and other soil types adjacent, as shown on Figure 4.16. These soil types within the Project Area were obtained from soil and land resource datasets on the Queensland Government's open data portal.

Sections C to E are characterised as predominantly hard-setting Dermosol with undulating rises and low hills on sedimentary rocks and greenstone, with saline seepage on lower slopes and drainage lines, shallow, brown, structured clay loams and clays, shallow, gravelly, massive loams, and ironbark woodland and gum-topped box woodland. The surface drainage is classified as four, and its permeability is rated as three. Dermosol soils are soils other than vertosols, hydrosols, calcarosols and ferrosols that have B2 horizons that have a grade of pedality throughout the major part of the horizon and do not have a clear textural B horizon.

Section A to B is characterised as being predominantly hard-setting Rudosol with volcanic hills and mountains with eucalypt forest in the northeast. The surface drainage is classed as five, and its permeability is three. Rudosol soils have little to no pedologic organisation. They are a pedal or weakly structured in the A1 horizon and show no pedological colour changes apart from the darkening of an A1 horizon. Additionally, there is little to no texture or colour changes with depth. Section A is characterised by predominantly hard-setting Sodosol with strongly undulating volcanic country, mainly silver-leaved ironbark, in the east and northeast. The surface drainage is classed as three, and its permeability is one. Sodosol soils have a clear textural B horizon and are sodic and not strongly acidic, which can lead to high erosion risk.

The development of erosion and salinity problems on marginal land has led to land management being identified as a high priority to reduce sediment loads being transported by rivers into the GBR. These considerations are later addressed in Section 7, 8 and 9, in relation to the Reef 2050 Water Quality Improvement Plan.

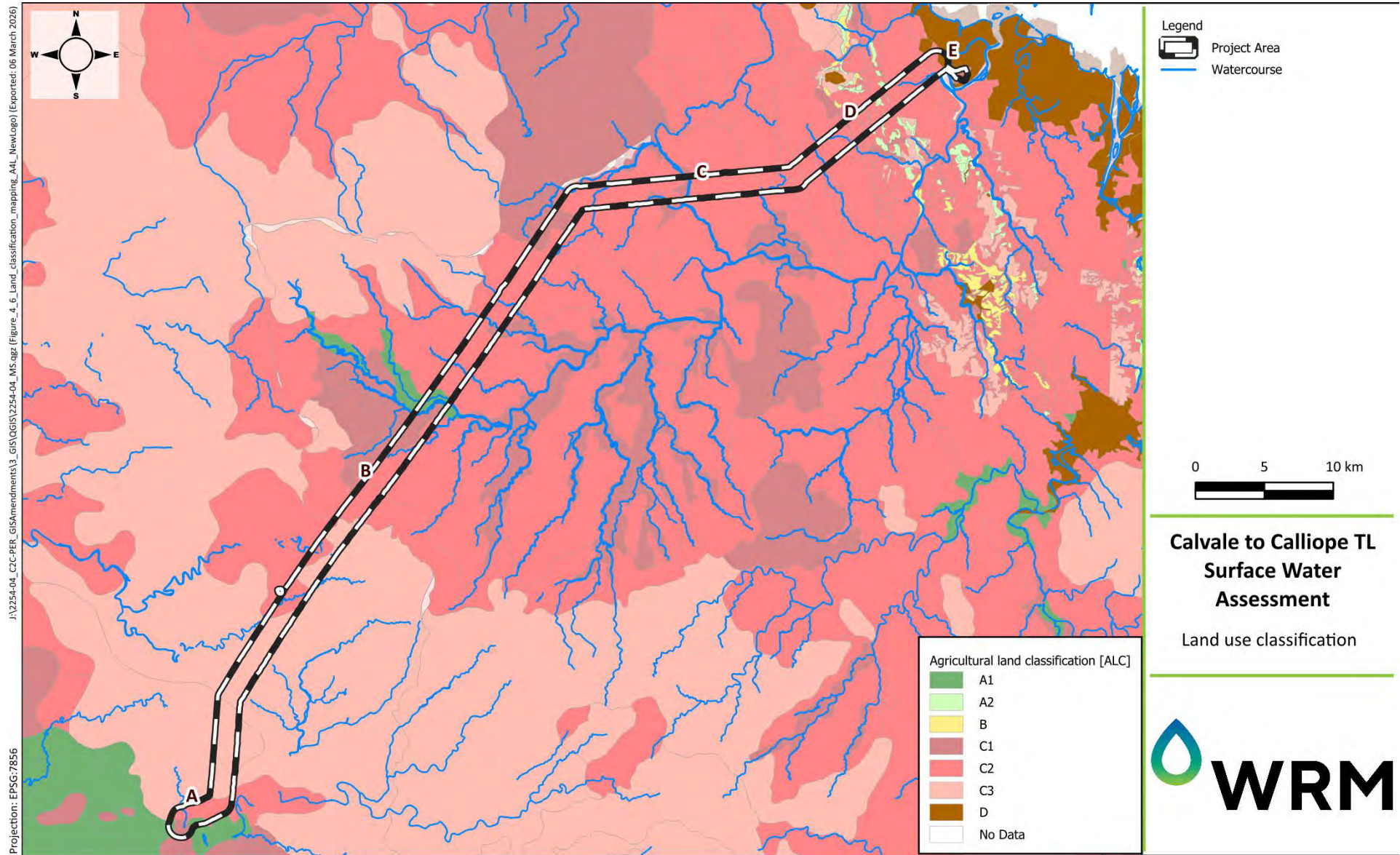

Figure 4.15 Agricultural Land Classification

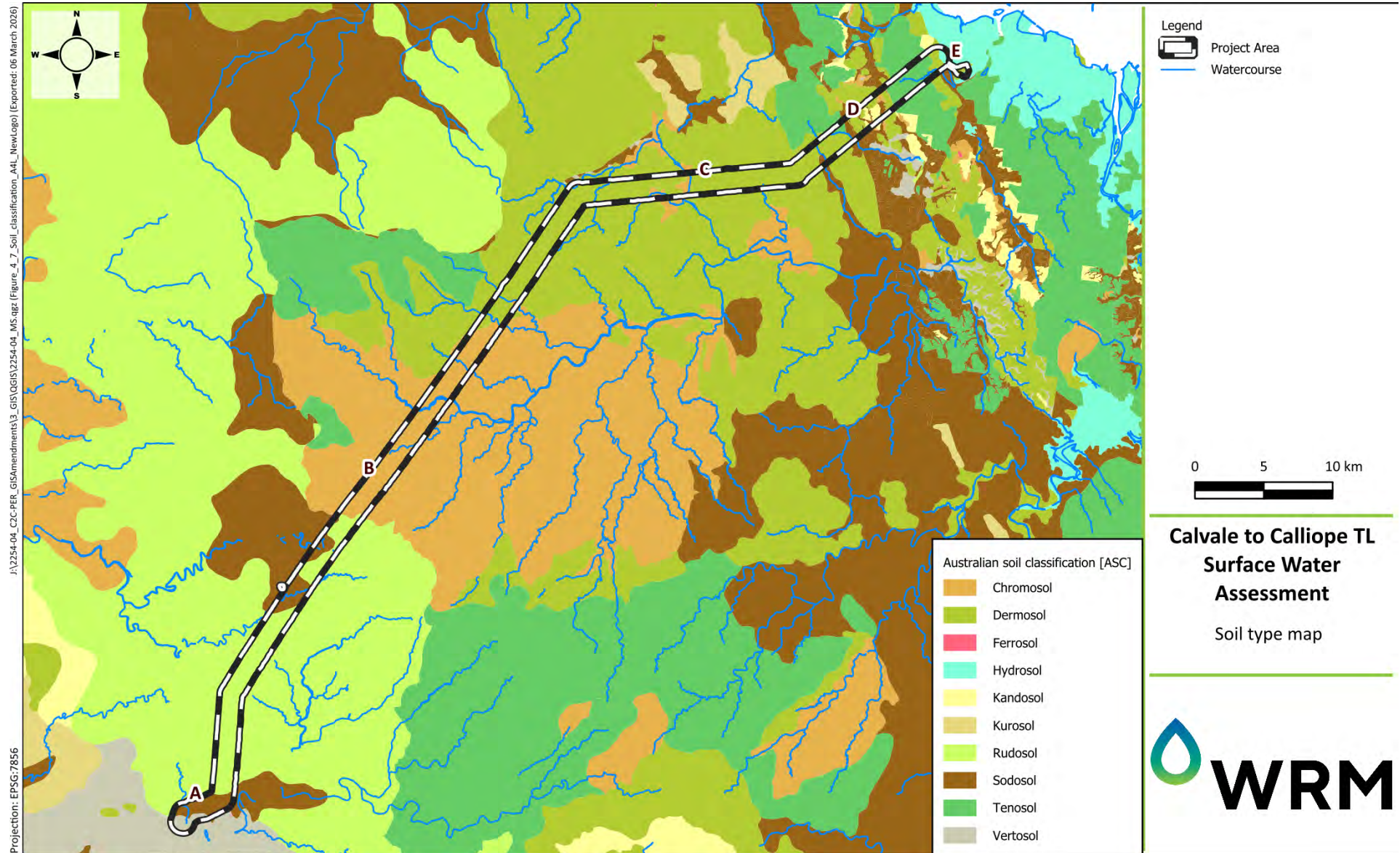

Figure 4.16 Australian Soil Classification

5 MODELLING APPROACH

5.1 OVERVIEW

A TUFLOW hydrodynamic model was developed to simulate the flow behaviour arriving at the Project Area for the 10%, 1% and 0.2% annual exceedance probability (AEP) events under the current climate and the future climate 2090 projection, Shared Societal Pathway (SSP3) scenario.

Discharges within the Project Area were estimated by applying rainfall directly to the topographic surface in the hydraulic model. Design discharges were determined using the ensemble methodology described in Australian Rainfall Runoff v4.2 guidelines (AR&R v4.2) (Ball et al., 2019). An ensemble of 10 temporal patterns is modelled for each storm duration to derive a range of estimated peak discharges for storms of different severity, represented by an AEP. The storm duration with the highest median peak discharge of the ensemble is selected, and the temporal pattern that produces the peak discharge just above the ensemble median is used for design event modelling.

The direct rainfall (also known as rain-on-grid) approach was adopted for the assessment. Design rainfall depth data, design losses, and storm pre-burst details were obtained from the ARR Data Hub.

Preliminary TUFLOW hydraulic model runs for a range of durations and temporal patterns were used to identify the critical storm durations for the Project Area and to determine the relevant design storm temporal patterns.

Design storm modelling results were post-processed to derive design flood characteristics (e.g., peak flood depths and extents) for each climate scenario for the existing catchment. The impacts of climate change for each AEP event were assessed by subtracting the current climate event results from the future climate event results. This difference map showed the location and magnitude of predicted climate impacts.

5.2 DESIGN RAINFALL DEPTHS

Design rainfall depths were obtained using the following methodology:

- Design rainfalls based on historic climate, for the 10%, 1% and 0.2% AEP events were obtained from the Design Rainfall Data System¹ based on a single point location at the centroid of the Project Area.
- Current climate rainfall estimates were increased in line with the AR&R v4.2 climate change guidance. The increase in rainfall depths increases, depending on duration, by 8% to 32% between historic 2016 IFD's to current climate and by 15% to 25% from 2030 SSP3 to 2090 SSP3².
- Areal reduction factors (ARF) derived for the Project Area's catchment (2793 km²) were applied to these design rainfalls. Table 5.1 and Table 5.2 shows the current and future climate's reduced design rainfall depths for the 10% (1 in 10), 1% (1 in 100) and 0.2% (1 in 500) AEP for durations from 15 minutes to 12 hours.

¹ <http://www.bom.gov.au/water/designRainfalls/revise-ifd/>

² Preliminary modelling chose a central IFD location, this is subject to change in later modelling phases.

Table 5.1 Adopted design rainfall depths – Current Climate

Duration (mins)	10% AEP	1% AEP	0.2 % AEP
	Current Climate IFD		
60	32.9	41.1	48.3
90	41.8	52.4	61.4
120	48.5	60.9	70.4
180	59.1	74.9	86.3
270	73.4	100.1	118.8
360	87.2	128.5	159.9
540	108.2	170.7	217.8
720	124.8	201.8	257.6

Table 5.2 Adopted design rainfall depths – Future Climate

Duration (mins)	10% AEP	1% AEP	0.2 % AEP
	Future Climate IFD 2090 SSP3		
60	44.1	55.1	64.8
90	54.8	68.6	80.4
120	62.4	78.4	90.6
180	74.7	94.6	109
270	91	124.2	147.4
360	106.9	157.5	196.1
540	131	206.5	263.5
720	149.5	241.8	308.7

Source: BOM.gov.au, Latitude: - 24.0954, Longitude: 150.8984

5.2.1 ARR Data Hub

Recommended design rainfall parameters were provided in the ARR Data Hub portal³. Key design rainfall parameter values included:

- Initial and continuous loss rates;
- Design storm pre-burst depths;
- Areal reduction factors; and
- Design storm temporal patterns.

5.2.2 Design rainfall losses and pre-burst rainfall

The Storm initial loss (IL) and continuing loss (CL) method of accounting for rainfall losses was adopted in accordance with ARR Data Hub recommendations. An IL and a CL were adopted, with median pre-burst depths obtained from the ARR Data Hub used to adjust the initial loss with 1% AEP.

³ <https://data.arr-software.org/>

IL and CL were derived by extrapolating between rainfall losses adopted for infrequent events (up to 1% AEP) and the minimum rainfall loss, noting that:

- Initial losses (ILs) for infrequent events were derived based on the Probability Neutral Burst ILs provided by ARR Data Hub. This approach results in a unique IL for each duration.
- Continuing losses (CLs) for infrequent events were derived based on the suggested ARR Data Hub and regional flood study CLs.

Table 5.3 provides the initial and continuing losses for the infrequent events used to interpolate the 0.5% and 0.2% AEP rainfall losses. Table 5.4 provides the Probability Neutral Burst Initial Loss values referred to by Table 5.3.

Table 5.3 Adopted design rainfall losses

Losses	Infrequent (to 1% AEP)
Initial loss (mm)	Probability Neutral Burst Initial Loss (see Table 5.4)
Continuing loss (mm/h) current climate	1.7
Continuing loss (mm/h) future climate	1.8

Table 5.4 Probability Neutral Burst Initial Loss - Current Climate

Storm duration	Probability Neutral Burst Initial Loss (mm)	
	10% AEP	1% AEP
1 hours	24.2	20.1
2 hours	24.5	17.5
3 hours	24.6	15.7
4.5 hours	22.1	9.1
6 hours	19.7	2.6
9 hours	19.0	-9.2
12 hours	18.3	-20.9

Table 5.5 Probability Neutral Burst Initial Loss - Future Climate (2090 SSP3)

Storm duration	Probability Neutral Burst Initial Loss (mm)	
	10% AEP	1% AEP
1 hours	25.19	20.92
2 hours	25.51	18.25
3 hours	25.62	16.33
4.5 hours	23.06	9.50
6 hours	20.50	2.67
9 hours	19.80	-9.55
12 hours	19.11	-21.78

Design temporal patterns

Design event hydrology was modelled using the ensemble of temporal patterns approach in accordance with AR&R v4.2 2019. The design temporal patterns were adopted from the areal temporal patterns from AR&R v4.2 2019. Temporal patterns were obtained from the ARR Data Hub based on a point location at the centroid of the catchment. The Australian Rainfall and Runoff guidelines identify 10 temporal patterns, yielding 10 unique design storms for each critical duration and AEP. The model was run using representative temporal patterns for storm durations ranging from 15 minutes to 12 hours for the 10%, 2%, and 1% AEP events. The critical storm duration was identified as the duration that produced the highest median peak discharge among the 10 design storms.

5.3 HYDRAULIC MODELLING

The 2023-03-AF version of the two-dimensional TUFLOW hydrodynamic model was used to simulate the existing catchment flow behaviour in the Project Area for the 10%, 1%, and 0.2% AEP events under the current and future (2090, SSP3) climates.

The direct rainfall approach was adopted for the assessment. The TUFLOW hydraulic model was run for durations and temporal patterns to identify the critical storm duration and median temporal pattern within the Project Area.

5.3.1 Topography and grid cell size

Powerlink provided high-resolution LiDAR data along the transmission line corridor. This LiDAR also captured reflections from the existing power lines. Although the transmission corridor was surveyed using LiDAR, the coverage was insufficient for modelling purposes. The regional catchment model was derived from the best available elevation data.

In much of Section D and all of Section E, high-resolution LiDAR was available, which could be combined with the Powerlink LiDAR. To the west of Section D, the regional elevation coverage was often the much coarser Copernicus satellite topography (30-metre grid cell).

Efforts were made to use these two very different scale datasets. When setting up the hydraulic model, the two datasets could not be loaded into available memory. Running the model with both datasets combined caused the regional elevation model to struggle to work with the LiDAR data. Various techniques were tried to fix this numerical issue. Figure 5.1 and Figure 5.2 compares the difference in the modelled results when using both LiDAR and Copernicus data, versus just using the Copernicus dataset only approach.

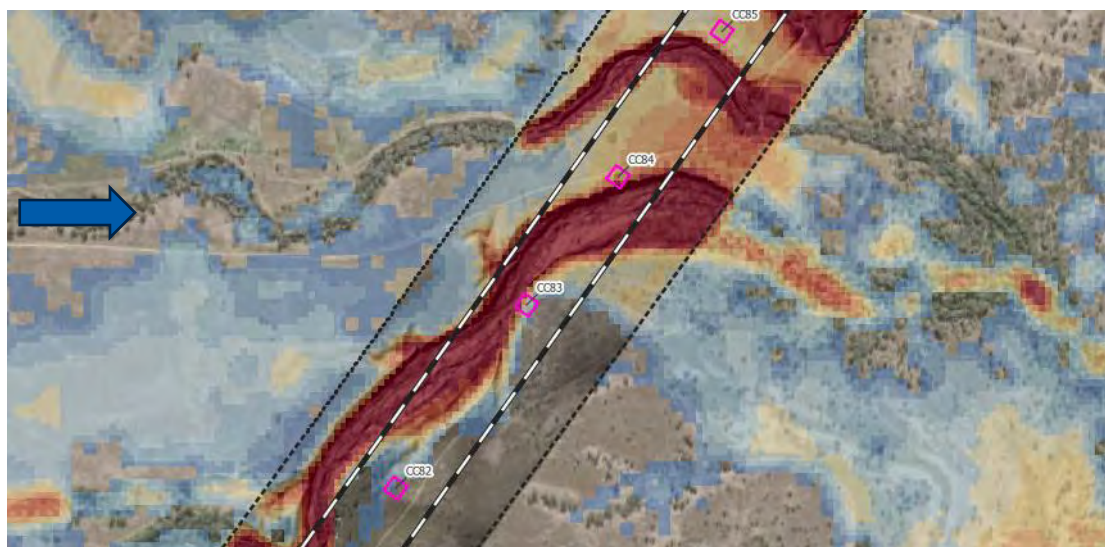

Figure 5.1 Flood depth results from LiDAR and Copernicus terrain in Section B

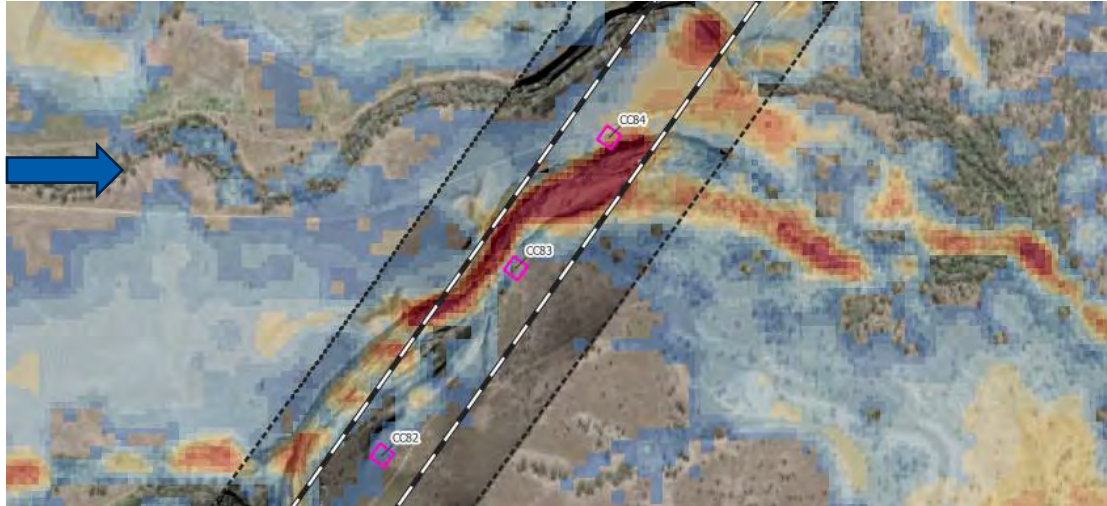

Figure 5.2 Flood depth results from Copernicus terrain only in Section B

Figure 5.1 shows the very high and unrealistic depths within the corridor. Effectively, the modelled water can enter the LiDAR region, but due to discrepancies in absolute elevation, the modelling of water is unable to drain. Modelled results then show peak depths around tower sites CC83 and CC84 that are unrealistic, caused by this artefact.

Ultimately, the modelling approach for the Sections where no regional LiDAR was available was to adopt the available Copernicus data. The Copernicus-only approach ensured that any elevation discrepancies remained relative, and no significant changes in absolute elevation were introduced. Where required, the Copernicus data values were edited to reflect LiDAR drainage paths. A 30-metre grid resolution is adequate for basin-wide hydraulic modelling of catchment flows, but introduces limitations regarding elevations and velocities. Due to the usage of this coarse dataset, the modelled outputs for Sections A through C can only be considered as suitable for generating flows and flood extents. The modelled results are not appropriate for calculating peak flood velocities or absolute design elevations.

5.3.2 Boundary conditions

Figure 5.3 shows the model domain. A rainfall (2d_rf) polygon was applied over the hydraulic model extent, enabling a direct rainfall approach in the assessment.

A normal depth rating curve (HQ) type boundary condition was implemented as the downstream model boundaries. The model boundaries were set well downstream of the Project Area to minimise any influence on predicted flood behaviour near the Project Area. The downstream boundary conditions assumed a normal depth slope of 0.005 m/m at the main ocean outlet; other areas were typically between 0.002 and 0.06 m/m, with a steeper northern boundary slope of 0.171 m/m. These depth slopes were calculated from the channel slopes extracted from topographic data. This normal depth slope is typical of water-surface slopes.

5.3.3 Hydraulic structures

No surveyed hydraulic structures were available within the Project Area. WRM were not aware that the Project's design required any hydraulic structures to be included in the model.

5.3.4 Hydraulic resistance

The TUFLOW model represents hydraulic resistance using Manning’s ‘n’ values. Analysis of available aerial imagery and land cover mapping identified seven general land-use classifications relevant to the Project Area. As this was a direct rainfall model, the adopted Manning’s ‘n’ values for each land use classification are listed in Table 5.6. These values are typical for models constructed in Southern Queensland.

Table 5.6 Adopted hydraulic roughness coefficients

Land use description	Manning’s ‘n’ coefficient
Active channel with light vegetation	0.035
Dense vegetation	0.080
Medium vegetation	0.060
Light vegetation	0.045
Exposed dirt/unsealed road	0.025
Roads	0.020
Water body/lake	0.020
Bed channel	0.025
Forest	0.100
Dense forest	0.120
Urban residential	0.100
Building structure	0.400

NOTE ON FLOOD TERMINOLOGY

This report discusses concepts related to flood risk. A design flood is a probabilistic or statistical estimate, typically based on a probability analysis of flood or rainfall data. An Annual Exceedance Probability (AEP) is assigned to this estimate. The frequency of flood events is expressed as an AEP; for example, a flood with a 10% AEP means there is a 10% probability (or 1 in 10 chance) that floods of that magnitude or greater will occur each year. While the related concept of Annual Recurrence Interval (ARI) is now outdated due to the confusion it causes, a flood with a 10-year ARI is one with a magnitude equal to or greater than that of a flood that occurs once every 10 years on average.

The frequency of flood events can be categorised into five broad descriptive groups: ‘Very Frequent’, ‘Frequent’, ‘Rare’, ‘Very Rare’, and ‘Extreme’. This report classifies a 1% AEP flood as ‘Very Rare’, but acknowledges it remains within the credible limit when extrapolating from historical climate records. In recent years, climate data has shown the influence of non-stationarity, with evidence indicating that flood magnitudes—based on historical data—are becoming more frequent. This trend is expected to continue as our climate warms, leading to increased atmospheric moisture.

Very rare design flood events are helpful for planning purposes because of their remote likelihood of occurrence. Extreme floods are considered well beyond the credible limits of historical records and are subject to significant uncertainty, serving mainly as theoretical upper bounds. Very rare flood events are essential for planning, as they occur with a remote chance during the asset’s lifetime. For long-lived, high-consequence assets, it may be appropriate to determine a design flood probability related to potential consequences over the asset’s lifespan.

Estimating an actual or historic flood resulting from a specific rainfall event is inherently different; it is a deterministic process. All causes and effects are directly linked to the particular event under



analysis. The antecedent conditions present at the time of the rainfall are reflected in the resulting flood, and these conditions must be taken into account in the estimate. No definitive information about the probability of a historic flood can be obtained from considering a single flood event alone.



Figure 5.3 Hydraulic model configuration

6 FLOOD MODEL RESULTS AND ANALYSIS

6.1 OVERVIEW

This section discusses the likely impact on flood behaviour under the current climate scenario and the future climate scenario projected to 2090 under the Shared Societal Pathway 3 (SSP3). Flood modelling was undertaken to estimate changes in flood flows for the 10%, 1% and 0.2% AEP under the current and future (2090, SSP3) climates. This section appraises surface water flooding behaviour in relation to the infrastructure shown in Appendix A.

The flood modelling of the Project Area was limited to calibrating and validating modelled flows. Furthermore, the coarse nature of the DEM available for the majority of the Project Area significantly limited the ability to conduct detailed hydraulic modelling. The provided flood mapping is coarse and limited by available survey data and is intended only to indicate possible flood extents within the Project Area corridor. Further discussion on the applicability is presented in Section 5.3.1.

6.2 LIMITATIONS

Modelling accuracy is subject to numerous sources of uncertainty. Some potential sources of inaccuracy leading to uncertainty in the hydraulic model are as follows:

- Inaccurate topographic information – The hydraulic model relies upon the representation of the ground topography to model the movement of water across the land. The DEM used to inform the model topography was captured at different times and with differing resolutions. This also implies a variance in vertical and horizontal accuracy for the survey. The accuracy of the DEM may impact the accuracy of model results. For example, the model may not be well-represented in minor flow paths smaller than the DEM resolution.
- No calibration to historical events—It is best practice to calibrate a hydraulic model to a historical event. However, calibration data for historical events is unavailable, rendering model calibration impossible. While the model parameters have been chosen in line with AR&R v4.2 2019 recommendations and within industry-accepted bounds, the model's ability to reproduce actual flood behaviour remains untested.
- Critical duration—A representative critical duration and temporal pattern have been selected to represent the flood behaviour across the Project Area. Given the broad scope of this impact assessment, this simplification is appropriate. However, future detailed design (e.g., of waterway crossings) may need to model additional durations to determine whether the critical duration at the location of interest should be updated.

6.3 DESIGN FLOOD EVENTS

The current and future climate flood extents, depths, and velocities for the Project Area are shown in the A3 maps in Appendix A. These flood maps show a variety of overland flow paths. For clarity, minor shallow depths (< 50mm) were removed from the maps. The purpose was a preliminary investigation to assess flood risk, which can inform the layout of the Project Area infrastructure.

The resulting output grids are statistically analysed to generate maximum water surface (depth) and velocity values from the median of the ensemble of temporal patterns from each set of storm durations.

6.3.1 Current Climate

The flood assessment has estimated flood extents, depths, and velocities for the 10%, 1%, and 0.2% AEP events under the current climate scenario. The flood maps show overland flow paths. For clarity, minor shallow depths (< 50mm) were removed from the maps. This depth would typically be managed via stormwater infrastructure. The purpose was a preliminary investigation to appraise flood risk that can inform the layout of site infrastructure.

The resulting output grids are statistically analysed to generate maximum water surface (depth) and velocity values from the median of the ensemble of temporal patterns from each set of storm durations for the current climate scenario.

During the detailed design phase of works, the new transmission line should be sited through careful consideration of topography. The modelling undertaken was limited and indicative only due to the coarse resolution of the available elevation grids in Larcom Creek. Modelled flows are approximate estimates that were not calibrated to local flood gauges or validated via RFFE. Appendix A provides corridor mapping with the best available information on where land may be flood-prone. This imagery also indicates the available terrain.

Summary observations related to flood behaviour, noting that flood maps are provided in Appendix A.2, are as follows:

- 10% AEP: The flood-mapped results indicate that the flows are confined to the minor drainage features within the Project Area. Broad areas of shallow flow are shown. Some relate to artefacts of the coarser resolution used within the flood model. Flow paths are developing and are well-formed.
- 1% AEP: The flow paths through the Project Area are beginning to spread outside their natural watercourses. In general, flood flows are becoming more hazardous throughout the Project Area. Large flow paths are forming within the Calliope River and Larcom Creek catchments. Flood hazards are increasing due to deeper and faster flows in the watercourse.
- 0.2% (1 in 500) AEP: This flood event is considered very rare and provides an upper credible estimate of very rare floods based on the observational record. A large section is increasing in flood hazard. Peak modelled water depths are breaking out of the banks and flowing throughout the floodplain.

The towers are located on relatively higher land and above expected surface water flow paths. As such, there is no foreseeable mechanism for the tower's placement to disrupt overland flow and, in turn, generate afflux. Equally, impacts are considered unlikely outside of the Project Area.

Table 6.1 presents the estimated peak design discharge for the current climate scenario.

Table 6.1 Estimates of peak discharge at key locations - Current Climate

Location ID	Nearby Location	10% AEP (m3/s)	1% AEP (m3/s)	0.2% AEP (m3/s)
87	CC14	47.8	101.2	142
70	CC20	9.3	16.8	25.1
61	CC22	12.3	22.1	33
62	CC24	5.7	9	13.8
CollardsCk	CC40	27.1	48.8	73.2
CollardsCk3	CC44	7.1	11.6	17.8
CollardsCk5	CC47	25	67.8	144.8
BellCK1	CC55	137.4	302.4	487.9
RunningCk4	CC70	9.7	27.8	40.1
RunningCk6	CC73	128.5	244.4	335.8
RunningCk8	CC78	6.9	12.6	18.4
RunningCk9	CC80	2.3	4.1	6.2
CalliopeRv	CC83	434.8	1266.6	1713
AlmaCk1	CC85	29.6	107.9	281.9
ZigZagCk	CC90	42.4	86.8	126.4
HarperCk1	CC95	4.6	8.6	13.1
HarperCk2	CC96	38.1	88.4	129.1
HarperCk	CC98	148.6	340.5	503.6
PaddockCk	CC101	100	271.5	361.5
AlarmCk	CC104	12.1	32.6	43
AlarmCk2	CC105	22.5	48.6	68.9
BranchCk	CC122	86.8	187.4	271
BranchCk2	CC124	13.5	25.1	36.5
LarcomCk	CC131	45.9	99.9	132.3
LarcomCk3	CC135 CC134	316.5	1107.5	1769.5
LarcomCk5	CC133	57.3	137.3	201.4
LarcomCk6	CC139	38.7	94.4	124.1
CalliopeT2	CC144	10.3	21.3	29.2
FarmerCk	CC146	17.7	50.5	66.7
FarmerCk2	CC152	51.4	111.6	169.1
CalliopeRvT	CC180 CC181	6.2	19.7	25.6

6.3.2 Future Climate Scenario

The Project has an expected operational life of 50 years. In March 2024, the Australian Government’s Department of Climate Change, Energy, the Environment and Water (DCCEEW), in partnership with Engineers Australia and the National Emergency Management Agency, released the AR&R v4.2 Guideline chapter on Climate Change Considerations. The AR&R v4.2 guideline now recognises that rising global temperatures are linked to estimates of design rainfall. The AR&R v4.2 guideline provides a method to assess various climate scenarios. This consideration encompasses a range of factors that influence design flood estimates, including changes in rainfall losses, temporal patterns, and sea level rise. The latest AR&R v4.2 guidance indicates that the magnitude of a design flood event will increase over the Project’s design life.

The future climate scenario predicts an increase in peak modelled flows of between 22% to 90% for the 10% AEP event. The 1 in 500 AEP predicts that peak modelled flows will increase by 13% to 47%. These increases in flow also indicate a possible change to the geomorphological behaviour of the streams. The increase in flood severity will likely result in higher velocities and stream power, in turn causing shear stress along the existing watercourses. While towers are to be located on relatively higher land and above expected surface water flow paths, channel beds may begin to meander or widen from their existing courses. This impact and altered behaviour occurring within a watercourse is not related to the construction of towers, but to the general shift in flood behaviour. Given the overall uncertainty in future climate behaviour, future flood behaviour is unlikely to be wholly attributable to the presence of a tower.

Table 6.2 presents the estimated peak design discharge for the future climate scenario.

Table 6.2 Estimates of peak discharges at key locations - Future Climate (2090 SSP3)

Location ID	Nearby Location	10% AEP (m3/s)	1% AEP (m3/s)	0.2% AEP (m3/s)
87	CC14	64.9	142	178.1
70	CC20	12.2	25.1	31.2
61	CC22	16.2	33	41.7
62	CC24	7.7	13.8	17
CollardsCk	CC40	37.1	73.2	91.3
CollardsCk3	CC44	9.9	17.8	21.9
CollardsCk5	CC47	30.5	144.8	183.9
BellCK1	CC55	175.2	487.9	588
RunningCk4	CC70	13.9	40.1	52.9
RunningCk6	CC73	155.8	335.8	410.2
RunningCk8	CC78	8.7	18.4	23.1
RunningCk9	CC80	2.9	6.2	7.7
CalliopeRv	CC83	585.4	1713	2012.4
AlmaCk1	CC85	35.6	281.9	415
ZigZagCk	CC90	52.2	126.4	171.1
HarperCk1	CC95	5.9	13.1	16
HarperCk2	CC96	46.5	129.1	172.2
HarperCk	CC98	188.6	503.6	603.7
PaddockCk	CC101	143.1	361.5	451.8

Location ID	Nearby Location	10% AEP (m3/s)	1% AEP (m3/s)	0.2% AEP (m3/s)
AlarmCk	CC104	18.6	43	56.9
AlarmCk2	CC105	30	68.9	85.6
BranchCk	CC122	108.2	271	351.9
BranchCk2	CC124	16.7	36.5	44.5
LarcomCk	CC131	62.5	132.3	150.4
LarcomCk3	CC135 CC134	439.7	1769.5	2217.8
LarcomCk5	CC133	82.2	201.4	253.7
LarcomCk6	CC139	55.2	124.1	151.2
CalliopeT2	CC144	13.7	29.2	36.6
FarmerCk	CC146	26.2	66.7	81.8
FarmerCk2	CC152	66.6	169.1	202.9
CalliopeRvT	CC180 CC181	9.7	25.6	32.6

6.4 FLOOD VALIDATION

This assessment has undertaken indicative and regional-scale flood modelling of the likely best estimate of design flood events. This is not intended to represent any historical or actual event. A design flood is a probabilistic or statistical estimate, generally based on a probability analysis of flood or rainfall data. The frequency of 1% AEP flood events is categorised as on the boundary between rare and very rare. A 10% AEP flood is classified as on the boundary between frequent and rare.

The absence of recorded streamflow data in the Project Area prevented the calibration of flood flows. In this scenario, the typical approach is to estimate predicted flood discharges using the Regional Flood Frequency Estimation (RFFE) model. RFFE is a tool developed for AR&R v4.2 to estimate design flows for ungauged catchments. It uses a region-of-influence approach based on gauged data and at-site flood frequency estimates, similar to the analysis presented in Section 4.4. RFFE uses a parameter regression technique that relates rainfall intensity, catchment area, and catchment shape factor as follows:

$$\log_{10}(Q_{50\% AEP}) = b_0 + b_1(Area) + b_2(Intensity_{6h,50\% aep}) + b_3(Shape Factor)$$

Once the peak flow for the 50% AEP event is determined, the slope of the flood frequency curve is applied. This then allows the other flood frequencies to be estimated. Table 6.3 presents the RFFE results for numerous locations within the Project Area. The catchment area, the coordinates of the catchment's outlet, and the centroid are also shown. A review of the nearby regional FFAs indicates that no similar catchments to those of the catchments within the Project Area exist.

Table 6.3 Regional Flood Frequency Estimation of peak discharges

Location	Area (km ²)	Outlet	Centroid	Shape Factor	10% AEP	5% AEP	1% AEP
CC121	14.86	150.9296 -23.934	150.918 -23.956	0.713	405	678	1569
CC122	1.40	150.9441 -23.934	150.945 -23.936	0.255	265	463	1153
CC133	2.14	150.9699 -23.9310	150.974 -23.937	0.529	287	501	1255
CC135	263.2	150.9966 -23.9295	150.985 -23.874	0.385	748	1185	2540
CC144	1.05	151.0353 -23.9286	151.034 -23.921	0.832	265	461	1148

Location	Area (km ²)	Outlet	Centroid	Shape Factor	10% AEP	5% AEP	1% AEP
CC146	3.15	151.0458 -23.9263	151.042 -23.919	0.519	322	554	1346
CC151	6.50	151.0665 -23.9244	151.060 -23.905	0.900	370	632	1510
CC152	3.58	151.0673 -23.9238	151.073 -23.914	0.673	333	572	1391
CC160	9.31	151.0904 -23.9099	151.083 -23.893	0.655	398	671	1577
CC164	6.63	151.1108 -23.8951	151.100 -23.874	0.991	379	637	1489
CC166	4.36	151.1280 -23.8902	151.122 -23.883	0.479	397	675	1614
CC172	2.10	151.1613 -23.8639	151.154 -23.864	0.516	358	603	1414

Source: <https://rffe-2021.wmawater.com.au/>

Figure 6.1 and Figure 6.2 are scatter plots of the catchment area and the peak discharges presented in Table 6.3 and shown below as blue diamonds. The regional at-site flood frequency analysis areas and peak discharges are plotted in green.

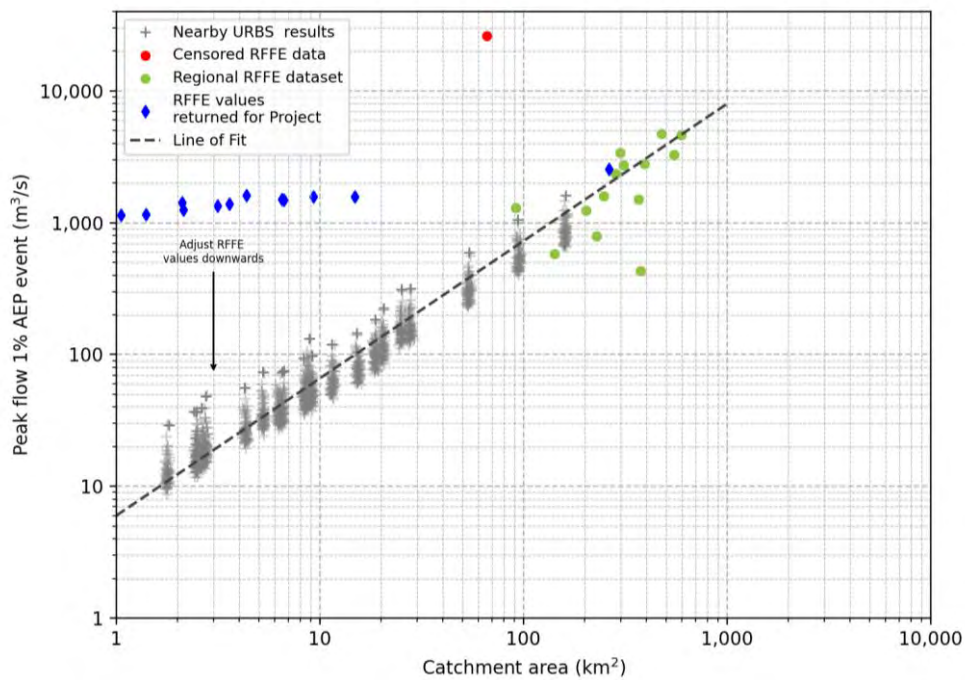

Figure 6.1 1% AEP from adjacent at-site FFA, nearby hydrologic models and RFFE output

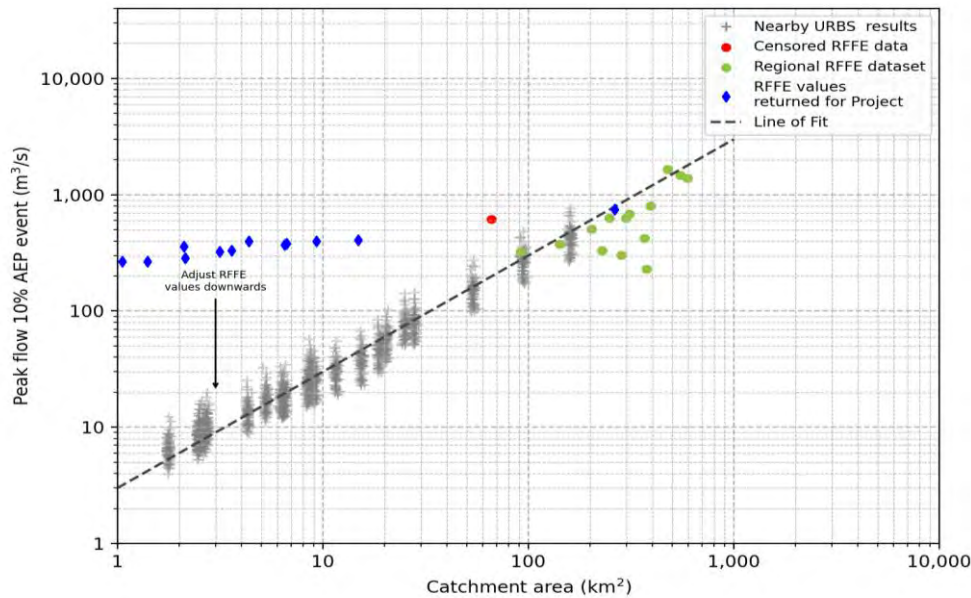

Figure 6.2 10% AEP from adjacent at-site FFA, nearby hydrologic models and RFFE output

An explanation for why the RFFE returns values that do not decrease with a diminishing catchment area lies in the equation's structure. The absence of regional flood frequency discharges with similar catchment areas to those in the Project Area appears to be a significant limitation. As such, the term related to the equation's catchment area can be reduced towards a unit value, and the other terms will dominate. Additionally, the at-site flood frequency analysis appears to incorporate an outlier from the Kenbula Station on the Dee River, shown as red in Figure 6.1 and Figure 6.2. The inclusion of this data point and the model schematisation appear to result in the RFFE model overpredicting peak discharges relative to catchment areas in the Project Area, as shown in blue.

To confirm this hypothesis, the peak-modelled flows from an available URBS hydrologic model, also located in the Calliope River basin, are shown in the figures as grey plotting positions. These URBS results fit with the expected behaviour of the at-site flood frequency analysis values shown in green.

The original RFFE values were adjusted to account for these demonstrated anomalies. The values shown in Table 6.4 were adjusted based on fitting the values in Table 6.3 to a more natural relationship. Table 6.4 provides a summary of likely estimates of regional flood frequency at each location after allowing for the catchment area.

Table 6.4 Adjusted RFFE model peak discharge

Location	Area (km ²)	10% AEP	5% AEP	1% AEP
CC121 Branch Creek	14.86	43	65	119
CC133 Larcom Creek Trib	2.14	6.2	9.3	17
CC135 Larcom Creek (d/s)	263.2	763	1145	2106
CC144 Tributary	1.05	3.0	4.6	8.4
CC151 Farmer Creek	6.50	19	28	52
CC160 Gravel Creek	9.31	27	40	74
CC164 Oaky Creek	6.63	19	29	53

7 POTENTIAL IMPACTS ON MNES

7.1 OVERVIEW

In the absence of appropriate controls and assuming the worst-case scenario, the potential impacts of the Project on MNES are listed below. While these potential impacts may primarily occur during construction and decommissioning, they also may occur during operation. The potential impacts are as follows:

- degradation of surface water quality due to:
 - elevated concentrations of sediment and nutrients bound to sediment in any runoff;
 - elevated pH and fine sediment concentrations in runoff from mobile concrete batching plant areas;
 - chemical spills/leaks entering streams (e.g. diesel fuel or hydraulic oils from mobile plant);
- increased erosion within watercourses due to:
 - damage to stream bed and bank from construction activities adjacent to and in-stream (e.g. stream crossings);
 - damage to riparian vegetation from construction activities on stream banks and land adjacent to watercourses;
 - runoff being concentrated by impervious areas associated with the Project;
- potential for alteration of flood flows and levels due to infrastructure located in close proximity to streams and watercourse networks;
- loss of catchment yield during construction due to capture of water in sediment dams;

The following is an itemised discussion of these potential impacts as they relate to the identified themes within the PER guidelines. Appendix A contains a response table to be read in conjunction with Sections 7 and 9. Section 9 presents the management and mitigation measures related to these impact themes.

An assessment of the potential impacts of the Project within and downstream of the Project Area was undertaken by using the details presented in earlier Sections. This included regional flood modelling, examination of aerial photography, and assessment of the layout of the proposed Project. In brief, the Project will require the construction of access tracks and platforms around the towers. During construction, construction compounds and laydown areas will be established. In aggregate, the construction will lead to an increase in impervious area, resulting in localised increases in runoff rate and volume. The net change in impervious area is negligible when compared with the overall catchment size.

Section 4 presents the findings of the desktop study and the soil resources. Section 2 outlines the Project activities and the commitment to minimal surface disturbance, along with a strategy to progressively restore the land to its pre-disturbance agricultural capability and usage.

7.2 ID#1 - RISK OF INCREASED SEDIMENT AND EROSION RUN-OFF

During the construction and decommissioning of components of the Project, soils will be disturbed, potentially leading to sediments and/or pollutants being entrained in rainfall runoff and entering local waterways during vegetation removal, excavation, and material stockpiling. Discharge of sediment-laden runoff from the Project has the potential to result in the deterioration of the downstream receiving water quality, for example:

- The Project may disrupt soils, leading to the generation of sediments, which in turn will bind with oils/grease and other nutrients.
- Works within or near a watercourse are a risk to downstream water quality due to the disturbance and the mobilisation of sediments and pollutants. Work occurring outside watercourse networks may also indirectly mobilise sediment and pollutants via wind and rainfall. Construction of the Project would not require controlled discharges to watercourses.
- Mobilised sediments, including high concentrations of nutrients (fertilisers), may trigger algal blooms that result in anoxic conditions within any fish habitat. Mobilised sediments containing heavy metals and other contaminants can degrade aquatic habitats.
- Soils within the Project Area may contain residual herbicides/pesticides from historical or present-day farming practices.
- Loss of topsoil resources on the land and ongoing erosion may reduce the area of arable land and/or damage private property.
- Erosion and sediment mobilisation may lead to degradation of water quality in lakes, estuaries and dams. This, in turn, will impact the health of the ecosystem and impact aquatic fauna and flora, as well as increasing turbidity and decreasing water quality in downstream watercourses.

7.3 ID#2 - RISK OF IMPACTS ON STREAM STABILITY AND RIPARIAN HEALTH

Without undertaking progressive and effective rehabilitation, the Project may affect stream stability and the hydrologic regime. Peak stormwater discharges from the Project Area for impervious areas may increase slightly through the creation of compacted gravel roads and some small hardstands. Exposing large areas will increase water volumes and runoff rates. This, in turn, increases the risk from higher flow rates impacting the downstream watercourses. Over time, these higher flows will alter the stream's geomorphology, leading to bank slumping and erosion.

7.4 ID#3 - RISK TO RECEIVING WATER QUALITY ASPECTS

The Project Area traverses several watercourses and drainage features. The potential impacts of the Project may include changes in water quality characteristics, including temperature, which in turn may adversely affect biodiversity, ecological health, or aquatic ecosystems. Other potential impacts of the Project may include the release or mobilisation of persistent organic chemicals, heavy metals, or other potentially harmful chemicals that accumulate in the aquatic or marine environment, leading to adverse outcomes for biodiversity, ecological and aquatic health.

Potential works that may impact surface water quality during the project's construction phase include those associated with Disturbance Footprint clearance and site preparation. Additional construction activities related to foundation construction, drainage works, and the use and storage of chemicals, such as fuel, additives, and lubricants.

Other potential water quality impacts during the operational phase associated with the day-to-day activities during this phase would be limited to:

- Stormwater runoff from impervious surfaces results in localised erosion.
- Accidental spills or discharge through the use and storage of chemicals such as fuel.

7.5 ID#4 - RISK OF INCREASED SEDIMENT AND EROSION DUE TO FUTURE CLIMATE SCENARIO

The Project has an expected operational life of 50 years, and so will be influenced by future climate rainfall and flooding. The analysis has implemented the latest AR&R v4.2 Guideline, which instructs that rising global temperatures are linked to estimates of design rainfall and flood magnitude. Over the long term, the Project will be subject to an increasing frequency of storm events, and so any soil disturbance and erosion could be expected to occur more frequently. This change is unrelated to the Project, so observed changes cannot necessarily be attributed to it.

The potential impacts of future climate scenarios range from SSP1 (very-low emissions) to SSP5 (high emissions). Noting the wide uncertainty for each pathway, the future climate (2090) flood modelling used the SSP3 scenario. The modelling indicates that flood flows will increase, and this has the potential to lead to more sediments and/or pollutants entering waterways. The Project is likely to require ongoing maintenance and vegetation clearance activities; this, coupled with predicted increases in rainfall event severity, may compound the potential impacts on erosion and sediment generation.

7.6 ID#5 - RISK OF INCREASED IMPACTS ON STREAM STABILITY DUE TO FUTURE CLIMATE SCENARIO

Future climate is predicted to lead to an increase in storm event magnitude, and thus, the potential impacts on downstream watercourses and their stability are significant. An increase in the frequency and magnitude of stream flows will compound the impact on downstream watercourses.

The potential impacts of flood modelling were assessed using the SSP3 scenario. The modelling of flows shows that regional flood flows will rise throughout. This will lead to higher stream power and bed shear stress within the downstream watercourses. The Project also extends to the tidal and coastal margins, so sea level rise will influence storm surge and peak water levels at the downstream limit of the watercourse.

8 MNES IMPACT ASSESSMENT

8.1 OVERVIEW

The following section presents an assessment of all relevant hydrologic impacts on MNES, including those during the Project's construction, operation and decommissioning stages. The risk assessment tables are presented in Appendix A and are to be read in conjunction with Sections 7 and 9.

This section summarises the qualitative risk evaluation undertaken to assess the potential risks associated with the Project. The assessment of impacts on MNES follows a systematic risk assessment methodology outlined in Australian Standard/New Zealand Standard (AS/NZS) ISO 31000:2018, *Risk Management—Principles and Guidelines (2009)*. For each MNES, the following process is applied:

- Identify Impact Pathways: Describe the mechanism by which the project activity could affect the MNES. This identifies the vulnerable element and its consequence;
- Characterise the Impact: Define the nature, extent, timing, and likelihood of the impact;
- Assess Significance: Evaluate the impact against the issued PER guidelines. This will analyse the likelihood and consequence ratings;
- Identify Mitigation Measures: Propose specific, measurable actions to avoid, mitigate, or manage the impact; and,
- Determine Residual Impact: Re-assess the significance of the impact after the application of mitigation measures.

8.2 METHODOLOGY

Risk assessment involves considering the sources of risk, their consequence and the likelihood of the defined incident occurring. Likelihood and consequences are combined to determine the level of risk. Therefore, risk criteria were developed to evaluate risk by distinguishing between the likelihood of the event and its implications. Likelihood is defined as a qualitative description of the probability and frequency of an event. Consequence is defined as the event's outcome expressed in terms of death, injury, loss, or some form of disadvantage.

Table 8.1 through Table 8.3 set out the criteria used to rank the likelihood and consequences of potential impacts, and how they are combined to determine the level of impact. The degree of likelihood is outlined in Table 8.1, while the magnitude of impacts/consequences is described in Table 8.2. Finally, the likelihood and impact magnitude are combined to be classified for the significance of impacts in Table 8.3.

Table 8.1 Qualitative measure of likelihood

Qualitative measure of likelihood (how likely is it that this event/issue will occur after control strategies have been put in place)	
Highly likely	Is expected to occur in most circumstances
Likely	Will probably occur during the life of the development
Possible	Might occur during the life of the development
Unlikely	Could occur but considered unlikely or doubtful
Rare	May occur in exceptional circumstances
Very rare	Likely to occur within a credible limit of extrapolation of observed events

Table 8.2 Qualitative measure of consequence

Qualitative measure of consequences (what will be the consequence/result if this issue does occur rating)	
Minor	Minor incident of environmental damage that can be reversed
Moderate	Isolated and short-term environmental damage
High	Substantial instances of environmental damage.
Major	Widespread and major loss of environmental amenity and real danger of continuing.
Critical	Severe widespread loss of environmental amenity and irrecoverable environmental damage

The level of risk depends on the likelihood of the risk occurring and its consequences. The risk criteria employed for this assessment, which were drawn from the ranking criteria presented in **Table 8.3**.

Table 8.3 Semi-qualitative risk rating matrix

Likelihood	Level of consequence				
	Insignificant	Minor	Moderate	Major	Catastrophic
Almost certain	Medium	High	Extreme	Extreme	Extreme
Likely	Medium	Medium	High	Extreme	Extreme
Possible	Low	Medium	Medium	High	Extreme
Unlikely	Very Low	Low	Medium	Medium	High
Rare	Negligible	Very Low	Low	Medium	Medium

9 MITIGATION AND MANAGEMENT MEASURES

9.1 OVERVIEW

Section 7 introduced the potential impacts on MNES aspects. This section presents the mitigation and management measures that will be utilised to reduce the risk to the lowest practicable level. Risk identification was undertaken based on:

- Assessing the activities associated with the Project presented in Section 3;
- Reviewing topography, soil types and surface geology in Section 4; and,
- Undertaking regional flood modelling and assessment in Sections 5 and 6;

The Project is a duplication of a transmission line in predominantly rural catchments adjacent to an existing transmission infrastructure. The primary risks relate to sediment discharge and alteration of stream morphology. Risk management measures documented for the Project are also detailed in:

- Baseline Water Quality Monitoring Plan (the Baseline WQMP), developed by Vision Environment.
- A Water Quality Management Plan (WQMP), developed by WRM, provides a framework for managing water quality during construction and operational phases of the Project.
 - The plan establishes monitoring, management and reporting protocols to protect receiving water quality and comply with regulatory requirements. This plan will consider and review the monitoring set out by the Baseline WQMP by Vision Environment
- Powerlink's Environmental Management Plan (EMP).

Appendix A summarises the unmitigated risks and was rated in terms of likelihood and consequence using the criteria presented in Table 8.1 and Table 8.2. Table 9.2 lists the management measures required to mitigate potential surface water impacts.

The primary objective is to ensure progressive rehabilitation during the construction of the Project. This will ensure minimisation of potential impacts. For all stages of the asset lifecycle, all measures are to comply with Powerlink's EMP.

9.2 MITIGATION AND MANAGEMENT MEASURES

Powerlink's EMP outlines the implementation of erosion and sediment control measures.

9.2.1 ID#1 - Mitigating an increase in sediment and erosion run-off

Powerlink's Principal Contractor will prepare a Construction ESCP in accordance with the IECA Best Practice Erosion and Sediment Control handbook⁴. At a high level, a range of mitigation measures identified to minimise these potential impacts are as follows:

- Design, construction and maintenance of erosion and sediment control measures will be in accordance with IECA's Best Practice handbook for guidelines (2008), which Queensland Local Councils and State Departments endorse;
- Disturbance Footprint drainage works will aim to minimise potential impacts on the existing overland flow paths. Where required, stream crossings will be built in accordance with Acceptable Design Requirements;

- A CEMP and ESCP will be developed for the Project by the Principal Contractor, detailing methods for minimising sediment-laden runoff in accordance with the Best Practice Erosion and Sediment Guidelines (IECA, 2008);
- For the various stages of work, develop and implement erosion and sediment control measures to be applied during the construction phase (including dust control). Erosion controls (e.g. rip rap) will be installed where considered necessary in accordance with Best Practice Erosion and Sediment Guidelines (IECA, 2008);
- Inspections will ensure controls are appropriate for the current construction phase and are suitably maintained. The inspections will identify areas ready to be rehabilitated and ensure that progressive rehabilitation can commence, and the state of existing rehabilitation areas for rehabilitation success, failure or signs of erosion;
- Following construction, areas that were cleared to facilitate the construction and not required for ongoing operation will be rehabilitated to the maximum extent practicable in accordance with the conditions of approval. This rehabilitation will occur progressively as construction stages of the Project are completed;
- In accordance with a Rehabilitation Management Plan, required to be developed by the Principal Contractor, re-vegetation of soil will be with native or naturalised perennial species to stabilise the land, reduce peak stormwater flows and reduce sediment discharge via stormwater runoff.

The potential for ongoing erosion post-construction for the Project is low, provided appropriate rehabilitation of disturbed areas is undertaken and any areas identified as exhibiting signs of erosion above expected background levels are addressed.

9.2.2 ID#2 - Mitigating impacts on stream stability and riparian health

A range of perennial and ephemeral flow paths and local depressions are located within the Project Area. While the Project design aims to avoid works close to or within waterways, waterway crossings will be required for site access. Project watercourse crossings will be designed to minimise impacts on stream stability (and fish passage), with reference to the ADR. Waterway crossings warrant consideration of flood conditions in these waterways and streams, with appropriate cross-drainage design to achieve flood immunity requirements for the access roads and internal access tracks. ADR⁵ fish passage requirements are dependent on the designated waterway, include:

- Construction duration limitations;
- Adequately sized culverts/ bed-level or low-level crossings to be provided to allow for the conveyance of overland flow under and/or across the access track;
- Adequate erosion protection across and downstream of the access track crossing should be provided;
- Provided the watercourse crossings are designed and constructed in accordance with relevant guidelines, the Project waterway crossings are not expected to result in any measurable impacts to stream health, including water quality and fish passage.

Where practicable, infrastructure will be sited and maintained outside of the vegetated riparian zone.

⁵ [Accepted development requirements for operational work that is constructing or raising waterway barrier works: September 2025](#)

- Rehabilitate disturbed areas and provide scour protection to bed and banks as required to mitigate any areas with increased potential for erosion due to changes in flow regimes associated with Project infrastructure in accordance with ADR;
- Where practicable, undertake works near streambanks during periods of low rainfall erosivity from April to September when construction timing restrictions are recommended;

The Project will increase impervious area by introducing hardstands and substation infrastructure, this will increase runoff. However, this increase in impervious area is negligible for the overall Project Area. Drainage from these impervious areas will not be directly connected, providing an opportunity for stormwater to be distributed and infiltrated between the impervious area and the receiving watercourse. Consequently, the hydrologic impacts of the Project at the catchment scale are likely to be undetectable.

9.2.3 ID#3 - Mitigating Water Quality Impacts

Appendix A summarises the Project's risk to the water quality objectives detailed by the following plans;

- Water Plan (Calliope River Basin) 2006, Section 9.3.3;
- Reef 2050 Water Quality Improvement Plan (2017-2022) section 0 describes how the Project is aligned with the local targets from the Fitzroy Region Calliope Catchment Water Quality Target.

Water quality mitigation will be achieved by adhering to the monitoring methodology provided in the WQMP and Powerlink's EMP. The EMP and related documents provide Powerlink's approach and measures for managing hazardous materials, including oils, fuels, and other chemicals. At a high level, a range of mitigation measures identified to minimise these potential impacts for ID#3 are as follows:

- Safe storage of chemicals and hydrocarbon materials (e.g. away from waterways and drainage lines), to ensure that any spillages are contained;
- All hazardous materials and chemicals would be stored in accordance with relevant Australian standards and other state and local guidelines.

Temporary use areas will be rehabilitated with the primary objective of achieving site stability, with a focus on establishing a grass cover. With the implementation of the outlined measures, the potential water quality impacts would be adequately managed during the Project's construction and decommissioning phases.

9.3 ALIGNMENT WITH REEF 2050 WATER QUALITY IMPROVEMENT PLAN –

9.3.1 Reef 2050 Water Quality Improvement Plan 2017-2022

The Reef 2050 Water Quality Improvement Plan (Reef 2050 WQIP) 2017-2022 aims to demonstrate the link between broader reef health and improving water quality, as well as the human factors that are key in influencing Reef health. These objectives demonstrate the nesting of the Reef 2050 WQIP within the Broader 2050 Plan. The Reef 2050 WQIP guides the achievement of the Reef 2050 Long-Term Sustainability Plan (Reef 2050 Plan) water quality themes for managing the GBR WHA.

Within the Reef 2050 WQIP, specific targets have been identified within the Fitzroy Region and the Calliope Catchment. The Project's WQMP will ensure compliance with the WQ targets listed in Appendix A-A.3.

9.3.2 Reef 2050 Long-Term Sustainability Plan 2021-25

Appendix A-A.2 outlines the relevant Reef 2050 Objectives and Goals 2021-25 in the theme of water quality management for the GBR WHA. The Reef 2050 Plan identifies seven themes: ecosystem

health, biodiversity, heritage, water quality, community benefits, economic benefits and governance, for managing the GBR WHA. The Project will comply with the Reef 2050 Plan.

9.3.3 Water Plan (Calliope River Basin) 2006

The purpose of the Water Plan (Calliope River Basin) 2006 is to:

- Define the availability of water in the plan area;
- Provide a framework for sustainably managing water and the taking of water;
- Identify priorities and mechanisms for addressing future water requirements;
- Reverse, where practicable, degradation that has occurred in natural ecosystems; and
- Regulate the capture and use of overland flow (i.e., surface runoff not contained in watercourses).

The Project's impacts on water quality, ecosystems, and ecological outcomes are consistent with the water quality targets established for the Fitzroy Region – Calliope Catchment.

9.3.4 Fitzroy Region Calliope catchment water quality target

Under the Reef 2050 WQIP, water quality targets have been set for each catchment that drains to the GBR. These targets account for land use and pollutant loads in each catchment. Water quality targets for the Fitzroy Region – Calliope Catchment are listed in Appendix A-A.3, and the WQMP details how the Project will monitor and comply with these targets.

9.4 CUMULATIVE IMPACTS

The Reef 2050 Plan requires cumulative impacts on the Reef to be assessed to achieve resilience to long-term threats, such as climate change. Land use along the alignment of the Project includes existing significant State linear infrastructure, transport corridors, gas pipelines, grazing and conservation areas. Related development from the Project will not change or alter the current land use.

Other unrelated projects in the surrounding area (i.e., within 20 km of the Project) may also impact the environment and the protected matters considered in this assessment. A review of the EPBC portal identified nearby projects. Table 9.1 lists these EPBC-related projects to assess the cumulative effects on relevant MNES.

The Project does not represent or comprise a significant increase in the existing level of development within the region. The Project will have a confined Disturbance Footprint. It will comply with best-practice surface water and erosion and sediment management methodologies to ensure any water-related impacts are managed and do not cumulatively affect the surrounding and downstream environments.

The Project's interface with other projects in the broader areas, as well as existing grazing, broadacre cropping, or conservation areas, is unlikely to interact with respect to watercourses. As such, cumulative impacts related to this Project are considered highly unlikely. Specifically:

- **Water Quality:** The Project will incorporate appropriate water management measures as far as practicable to achieve compliance with Calliope Water Quality Objectives and minimise any water quality impacts so as not to add to potential water quality impacts from upstream and downstream land uses and activities such as dredging.
- **Water Quantity:** The change in impervious area represents less than 0.5% of the total Project Area. Drainage from these impervious areas will not be directly connected, providing an opportunity for stormwater to be distributed and infiltrated between the impervious area and the receiving watercourse. Consequently, the hydrologic impacts of the Project at the catchment scale

are likely to be undetectable and therefore will not add to potential hydrological impacts from land uses upstream.

- The Project is unlikely to have impacts on marine MNES values due to the (1) Project's small linear nature of impacts being located sufficiently upstream of marine areas such as the GBRMP, and (2) the Project's mitigation and management measures. It is therefore unable to directly affect marine MNES values or contribute to potential impacts from other land uses. WQMP and ESCP practices identified for the project will ensure these habitats are not disturbed in accordance with the Reef 2050 Water Quality Improvement Plan.

Table 9.1 EPBC-referred projects within the 20 km buffer of the Project Area

Project Title and EPBC Reference Number	Industry Type	Status as at September 2025	Referral Outcome	Approximate Distance from Project Area (km)	Approximate Disturbance footprint (ha)	
Aluminium Smelter Expansion (2001/477)	Manufacturing	Post-Approval	Controlled Action	16.5	20	
Coal Mining Lease 6993 (The Bluff) (2002/569)	Mining	Post-Approval	Controlled Action	0.5	130	
Talisman Saber 2005 Military Exercise (2004/1819)	Commonwealth	Post-Approval	Controlled Action	3.0	unknown	
Install & operate gas pipeline (2005/2059)	Energy Generation and Supply (non-renewable)	Post-Approval	Controlled Action	Intersects Project Area	unknown	
Wiggins Island Coal Terminal (2005/2374)	Transport - Water	Post-Approval	Controlled Action	Intersects Project Area	520	
Gladstone - Fitzroy Pipeline (2007/3501)	Transport - Water	Post-Approval	Controlled Action	Intersects Project Area	330	
Curtis Island Liquefied Natural Gas (LNG) precinct and associated infrastructure	Development of a Natural Gas Liquefaction Park (2008/4057)	Energy Generation and Supply (non-renewable)	Post-Approval	Controlled Action	7.4	200
	Development of marine facilities to service the natural gas liquefaction park (2008/4058)	Energy Generation and Supply (non-renewable)	Post-Approval	Controlled Action	7.0	20
	Gas Pipeline with Alternative Pipeline to Supply Natural Gas Liquefaction Park (2008/4096)	Energy Generation and Supply (non-renewable)	Post-Approval	Controlled Action	Intersects Project Area	2,000
	Queensland Curtis LNG Project - Pipeline Network (2008/4399)	Energy Generation and Supply (non-renewable)	Post-Approval	Controlled Action	Intersects Project Area	3,680
	Queensland Curtis LNG Project - LNG Marine Facilities (2008/4401)	Energy Generation and Supply (non-renewable)	Post-Approval	Controlled Action	Intersects Project Area	40

Project Title and EPBC Reference Number	Industry Type	Status as at September 2025	Referral Outcome	Approximate Distance from Project Area (km)	Approximate Disturbance footprint (ha)
Development, Construction and Decommissioning of LNG Plant and Onshore Facilities (2008/4402)	Energy Generation and Supply (non-renewable)	Post-Approval	Controlled Action	7.4	300
Shipping Activities Associated with the QLD Curtis LNG Project (2008/4405)	Energy Generation and Supply (non-renewable)	Post-Approval	Controlled Action	6.0	unknown
Port of Gladstone Western Basin Strategic Dredging and Disposal Project (2009/4904)	Transport - Water	Post-Approval	Controlled Action	6.0	880
Construct and operate 447km high pressure gas transmission pipeline (2009/4976)	Energy Generation and Supply (non-renewable)	Post-Approval	Controlled Action	Intersects Project Area	2,682
LNG Plant and Ancillary onshore and marine facilities (2009/4977)	Energy Generation and Supply (non-renewable)	Post-Approval	Controlled Action	7.5	750
Boundary Hill South Lease Extension (2012/6324)	Mining	Post-Approval	Controlled Action	12.6	317
Port of Gladstone Gatcombe & Golding Cutting Channel Duplication Project (2012/6558)	Transport - Water	Post-Approval	Controlled Action	5.5	250
Turtle Street Beach Resort, Curtis Island, Qld (2015/7585)	Tourism and Recreation	Post-Approval	Controlled Action	17.5	20
Clinton Vessel Interaction Project - Clinton Widening, Qld (2017/7976)	Transport - Water	Post-Approval	Controlled Action	2.5	21
Lot 7 Borrow Pits, Aldoga Road, Gladstone, Qld (2018/8381)	Waste Management (sewerage)	Post-Approval	Controlled Action	4.7	121
Aldoga Solar Farm Project (2020/8773)	Energy Generation and Supply (renewable)	Post-Approval	Controlled Action	7.0	394

Project Title and EPBC Reference Number	Industry Type	Status as at September 2025	Referral Outcome	Approximate Distance from Project Area (km)	Approximate Disturbance footprint (ha)
Specimen Hill Wind Farm (2020/8864)	Energy Generation and Supply (renewable)	Post-Approval	Controlled Action	Intersects Project Area	836
H2-Hub Gladstone - Export-class Green Hydrogen and Ammonia Complex (2021/9049)	Manufacturing	Referral Decision	Controlled Action	Intersects Project Area	126
Callide Wind Farm (2021/9057)	Energy Generation and Supply (renewable)	Post-Approval	Controlled Action	2.5	896
Forest Springs - Commercial and residential development (2021/9135)	Commercial Development	Post-Approval	Controlled Action	6.0	60
Upper Calliope Solar Farm (2023/09752)	Energy Generation and Supply (renewable)	Assessment		Intersects Project Area	2,678
Hughes Road Battery Energy Storage System (2024/09892)	Energy Generation and Supply (renewable)	Assessment		14	4
Big G Pumped Hydropower Energy Storage (2024/10056)	Energy Generation and Supply (renewable)	Referral Decision		Intersects Project Area	507

9.5 SUMMARY AND TIMING OF MEASURES

Table 9.2 summarises the potential risk and outlines the timeframe for implementation of the measure.

Table 9.2 Management and Mitigation Measures relating to Water Resources

Potential Risk	Proposed Management and Mitigation Measure	Project Stage
Soil and water quality	Maintaining the natural state of the drainage flow paths whenever possible. Internal access roads, where crossing watercourses or streams, will be designed for 10% AEP design flow and may include compacted rock causeways to provide low-maintenance access with limited impact on the waterway or culvert structures.	Detailed design & Construction
Soil and water quality	A CEMP and Annexure will be prepared to outline measures to manage soil and water impacts associated with the construction and decommissioning works.	Prior to the Construction and Decommissioning phase
Soil and water quality	Erosion and sediment control measures will be implemented and maintained at all work sites in accordance with the principles and requirements in the CEMP and supporting management plans.	Prior to and during construction
Soil and water quality	Measures to minimise/manage erosion and sediment transport both within the construction footprint and offsite, including requirements for the preparation of ESCP for all progressive stages of construction.	Prior to and during construction
Soil and water quality	The best-practice principles for erosion and sediment control outlined in the guidelines will be incorporated into the design, construction, and operation phases as part of CEMP and supporting management plans.	Construction & Operation
Soil and water quality	Maintenance of stormwater infrastructure, including any stormwater treatment devices (e.g. swales, basins and culverts), e.g. clearing debris.	Construction
Soil and water quality	Maintenance of suitable ground cover and grassed table drains along access tracks to minimise the potential for erosion and sediment export.	Construction & Operation
Flooding	During construction design flood risk will be considered and include, as a minimum, a review of temporary infrastructure layouts and arrangements to a) avoid and/or minimise obstruction of overland flow paths, b) limit the extent of flow diversion, c) include stormwater management controls to avoid/minimise the impact of flooding, and d) consider measures to mitigate alterations to local runoff conditions due to on-site works and activities.	Construction
Stream stability, riparian health and fish passage	Temporary construction compounds, laydown areas, and concrete batching plans would be maintained away (or above) areas	Construction

Potential Risk	Proposed Management and Mitigation Measure	Project Stage
	<p>anticipated to flood to depths deeper than 250 mm during a 1% AEP flood event.</p> <p>Based on the Project design utilised for this assessment, this mitigation is achieved and will persist if any future design revisions occur.</p>	
Stream stability, riparian health and fish passage	Infrastructure with the potential to cause pollution to waterways in the event of flooding, will be located with a minimum 300 mm freeboard above the maximum 1% AEP flood level. Given the shallow depths across the Project Area, raising these small fill pads is highly unlikely to result in any adverse impacts off-site.	Detailed design
Stream stability, riparian health and fish passage	No flood-sensitive infrastructure will be placed within 20 m of any Strahler 3 or higher order streams, unless relocation is deemed essential and unavoidable. Sensitive infrastructure will be placed outside the flood extent with a minimum 300mm freeboard to the 1% AEP flood level.	Detailed design
Stream stability, riparian health	Controls for receiving waterways, which may include designation of 'no go' zones for construction plant and equipment.	Prior to Construction

10 CONCLUSION

10.1 SUMMARY OF KEY FINDINGS

This assessment estimated the likelihood and consequences of potential impacts on MNES relating to flooding and water quality. The purpose was to identify risks associated with the Project on MNES, including the WHA, NHL, and GBRMP. The Project Area comprises various critical infrastructure assets. The key assets comprise:

- High voltage overhead transmission line;
- Overhead and underground electrical reticulation;
- Substations and switching stations;
- Construction compounds and laydown areas; and,
- Operations and maintenance facilities.

10.1.1 Flood Assessment Outcome

Design flood estimates for locations within the Project Area are summarised and mapped in Appendix B. Future climate projections indicate that peak flows will increase over the Project's expected 50-year design life. However, hydraulic modelling suggests that the Project will not significantly alter regional flood behaviour. Changes to flood levels and velocities are negligible. Infrastructure locations were determined based on the consequences of the flood risk.

10.1.2 MNES and Water Quality

A significant impact assessment was undertaken regarding MNES. The assessment concluded that the Project will not have a substantial impact on the WHA. Furthermore, the NHL and GBRMP will not be adversely affected by changes in hydrology or water quality.

Potential soil and water quality impacts can be managed through an Erosion and Sediment Control Plan (ESCP). This plan will contain best-practice drainage, erosion, and sediment controls. The Baseline WQMP (Vision Environment, 2025) and WQMP (WRM, 2025) were developed to ensure that water quality is monitored and that appropriate triggers are in place. Consequently, construction-related water impacts are expected to be negligible.

10.1.3 Water Quality Management Plan Framework

A Water Quality Management Plan (WQMP) was developed to manage potential impacts during construction and decommissioning. This document operates subordinate to Powerlink's Environmental Management Plan (EMP). Management measures within the WQMP follow a specific hierarchy: avoid, minimise, mitigate, and rehabilitate. This approach ensures that disturbed surfaces are stabilised progressively to prevent sedimentation risks.

The WQMP establishes protocols for routine and event-based monitoring of indicators, including turbidity, pH, and nutrients. Trigger levels (Alert, Action, and Limit) are derived from the Baseline Water Quality Monitoring Program (Vision Environment, 2025) to ensure responses are tailored to local conditions. Adherence to this framework ensures compliance with the objectives of the Reef 2050 Water Quality Improvement Plan.

10.1.4 Cumulative Impacts

Hydrological and water quality assessments confirm that the Project will not contribute to cumulative impacts within the catchment. The Project does not represent a significant increase in the existing level of development within the region.

11 REFERENCES

BOM, 2024	Design Rainfall Data System (2016), Commonwealth of Australia. http://www.bom.gov.au/water/designRainfalls/revised-afd/
Queensland Government, 2023	<i>SILO – Australian Climate Data From 1889 to Yesterday</i>
Ball et al, 2019	<i>'Australian Rainfall and Runoff: A Guide to Flood Estimation'</i> , Ball J, Babister M, Nathan R, Weeks W, Weinmann E, Retallick M, Testoni I, (Editors), © Commonwealth of Australia (Geoscience Australia), 2019.
Geoscience Australia, 2019	AR&R Data Hub (software), Geoscience Australia, Version 2019_v1, April 2019, < http://data.arr-software.org/ >.
AIDR, 2017	<i>'Australian Disaster Resilience Handbook 7 Managing the Floodplain: A Guide to Best Practice in Flood Risk Management in Australia.'</i> Commonwealth of Australia 2017, third edition.
BMT, 2018	<i>TUFLOW User Manual Build 2018-03-AD</i> , BMT WBM Pty Ltd, 2018
BoM, 2025	<i>Design Rainfall Data System (2016), Commonwealth of Australia.</i> http://www.bom.gov.au/water/designRainfalls/revised-afd/
Geoscience Australia, 2019	ARR Datahub (software) Geoscience Australia 2024 v1.01 (11/09/24) https://data.arr-software.org
IECA, 2008.	Best Practice Erosion and Sediment Control. International Erosion Control Association.
WRM Water & Environment, 2025	Water Quality Management Plan Calvale to Calliope Transmission Line Reinforcement Project 2254-02-C1
Vison Environment, 2025	Baseline Water Quality Monitoring Plan
Zhang B., Carter J. 2018)	FORAGE – An online system for generating and delivering property-scale decision support information for grazing land and environmental management. <i>Computers and Electronics in Agriculture</i> , Volume 150, 302-311

12 ABBREVIATIONS AND DEFINITIONS

Table 12.1 Key project terminology

Term	Definition
Project Area	Total area that includes the disturbance footprint (s) and permanent and temporary works.
Rehabilitation	The restoration of land disturbed by The Project to its former condition (as much as practicable), to ensure it is safe, stable, and non-polluting.
Substation	<p>Under the <i>Electricity Act 1994 (S12)</i>, Works, substation and operating works are defined as</p> <p>(1) Works are anything used for, or in association with, the generation, transmission or supply of electricity. Example of works— electric lines and associated equipment, apparatus, electrical equipment, buildings, control cables, engines, fittings, lamps, machinery, meters, substations and transformers if they are used for, or in association with, the generation, transmission or supply of, electricity</p> <p>(2) A substation is a work used for converting, transforming or controlling electricity.</p>

Table 12.2 Flooding Abbreviations and Definitions

Term/ Abbreviation	Definition
AEP (Annual Exceedance Probability)	Annual Exceedance Probability. The change of a flood of a given or large size occurring in any one year, usually expressed as a percentage. In this study AEP has been used consistently to define the probability of occurrence of flooding. The following relationships between AEP and ARI applies to this study (ARR, 2019).

Term/ Abbreviation	Definition
-----------------------	------------

Frequency Descriptor	EY	AEP (%)	AEP (1 in x)	ARI
Very frequent	12			
	6	99.75	1.002	0.17
	4	98.17	1.02	0.25
	3	95.02	1.05	0.33
	2	86.47	1.16	0.50
Frequent	1	63.2	1.58	1.00
	0.69	50.00	2	1.44
	0.5	39.35	2.54	2.00
	0.22	20.00	5	4.48
	0.2	18.13	5.52	5.00
Infrequent	0.11	10.00	10.00	9.49
	0.05	5.00	20	20.0
	0.02	2.00	50	50.0
Rare	0.01	1.00	100	100
	0.005	0.50	200	200
	0.002	0.20	500	500
	0.001	0.10	1000	1000
	0.0005	0.05	2000	2000
Extremely Rare	0.0002	0.02	5000	5000
			↓	
Extreme			PMP	

AHD	Australian Height Datum. A common national surface level datum approximately corresponding to mean sea level.
ARR 2019	Australian Rainfall and Runoff. Guidelines prepared by the Institute of Engineers Australia for the estimation of design floods.
Discharge	The rate of flow of water measured in terms of volume per unit time, for example, cubic metres per second (m ³ /s). Discharge is different from speed or velocity of flow, which is a measure of how fast the water is moving for example, metres per second (m/s).
Flood	Relatively high stream flow which overtops the natural or artificial banks in any part of a stream, river, estuary, lake or dam, and/or local overland flooding associated with major drainage before entering a watercourse, and/or coastal inundation resulting from super-elevated sea levels and/or waves overtopping coastline defences excluding tsunami.
Flood risk	<p>Potential danger to personal safety and potential damage to property resulting from flooding. The degree of risk varies with circumstances across the full range of floods. Flood risk in this manual is divided into 3 types, existing, future and continuing risks. They are described below:</p> <p>Existing flood risk: the risk a community is exposed to as a result of its location on the floodplain.</p> <p>Future flood risk: the risk a community may be exposed to as a result of new development on the floodplain.</p> <p>Continuing flood risk: the risk a community is exposed to after floodplain risk management measures have been implemented. For a town protected by levees, the</p>

Term/ Abbreviation	Definition
	continuing flood risk is the consequences of the levees being overtopped. For an area without any floodplain risk management measures, the continuing flood risk is simply the existence of its flood exposure.
Flood storage areas	Those parts of the floodplain that are important for the temporary storage of floodwaters during the passage of a flood. The extent and behaviour of flood storage areas may change with flood severity, and loss of flood storage can increase the severity of flood impacts by reducing natural flood attenuation. Hence, it is necessary to investigate a range of flood sizes before defining flood storage areas.
Floodplain	Area of land which is subject to inundation by floods up to and including the probable maximum flood event, that is, flood-prone land.
ha	Hectares
Hazard	A source of potential harm or a situation with the potential to cause loss. In relation to this manual, the hazard is flooding, which has the potential to cause damage to the community.
Hydrology	The study of the rainfall and runoff process; in particular, the evaluation of peak flows, flow volumes and the derivation of hydrographs for a range of floods.
mAHD	Metres Australian Height Datum (AHD).
m/s	Metres per second. Unit used to describe the velocity of floodwaters.
m ³ /s	Cubic metres per second or “cumecs”. A unit of measurement of creek or river flows or discharges. It is the rate of flow of water measured in terms of volume per unit time.
MW	Megawatt.
Project Area	The total area in which The Project would be developed. the Project Area covers approximately 14,321 ha.
Risk	Chance of something happening that will have an impact. It is measured in terms of consequences and likelihood. In the context of the manual, it is the likelihood of consequences arising from the interaction of floods, communities, and the environment.
Runoff	The amount of rainfall which ends up as a streamflow, also known as rainfall excess.



APPENDIX A MNES RISK AND MITIGATION TABLES

A.1 MNES RESPONSE TABLE

Source: *Guidelines for a Draft Public Environment Report - EPBC 2024/10044 (the PER guidelines)*
 Matters of National Environmental Significance: Significant Impact Guidelines 1.1 - https://www.dcceew.gov.au/sites/default/files/documents/nes-guidelines_1.pdf

Potential Impacts to Surface Water	Relevant MNES	Pre-Mitigated Impact			Mitigation Measures	Residual (Mitigated) Impact	
		Likelihood	Consequence	Risk Score		Consequence	Risk rating
Modify, alter or inhibit landscape processes, for example, by accelerating or increasing susceptibility to erosion, or stabilising mobile landforms, such as sand dunes, in a World Heritage property.	World Heritage properties with natural heritage values: <i>Values associated with geology or landscapes</i>	Rare	Moderate	Low	<ul style="list-style-type: none"> Refer to ID#1 (Section 9.2.1). This will manage and mitigate sediment and erosion, which could be developed by the Project. 	Minor	Very Low
Divert, impound or channelise a river, wetland or other water body in a World Heritage property.	World Heritage properties with natural heritage values: <i>Values associated with geology or landscapes</i>	Rare	Moderate	Low	<ul style="list-style-type: none"> Refer to ID#2 (Section 9.2.2). This will manage the stability of watercourses, wetlands or other water bodies, mitigating any effects developed by the project. 	Minor	Very Low
Substantially increase concentrations of suspended sediment, nutrients, heavy metals, hydrocarbons, or other pollutants or substances in a river, wetland or water body in a World Heritage property.	World Heritage properties with natural heritage values: <i>Values associated with geology or landscapes</i>	Rare	Moderate	Low	<ul style="list-style-type: none"> Refer to ID#1 (Section 9.2.1). These sections will mitigate water quality issues that could be developed from the Project. 	Minor	Very Low
Introduce noise, odours, pollutants or other intrusive elements with substantial, long-term or permanent impacts on relevant values.	World Heritage properties with natural heritage values: <i>Wilderness, aesthetic, or other rare or unique environment values</i>	Rare	Moderate	Low	<ul style="list-style-type: none"> Refer to ID#1 (Section 9.2.1) and ID#2 (Section 9.2.3). These sections will mitigate water quality issues and sediment and erosion that could be caused by the Project. 	Minor	Very Low
Modify, alter or inhibit landscape processes, for example, by accelerating or increasing susceptibility to erosion, or stabilising mobile landforms, such as sand dunes in a National Heritage place.	National Heritage places with natural heritage values: <i>Values associated with geology or landscapes</i>	Rare	Moderate	Low	<ul style="list-style-type: none"> Refer to ID#1 (Section 9.2.1). This will manage and mitigate sediment and erosion, which could be developed by the Project. 	Minor	Very Low
Divert, impound or channelise a river, wetland or other water body in a National Heritage place.	National Heritage places with natural heritage values: <i>Values associated with geology or landscapes</i>	Rare	Moderate	Low	<ul style="list-style-type: none"> Refer to ID#2 (Section 9.2.2). This will manage the stability of watercourses, wetlands or other water bodies, mitigating any effect developed by the Project. 	Minor	Very Low
Substantially increase concentrations of suspended sediment, nutrients, heavy metals, hydrocarbons, or other pollutants or substances in a river, wetland or water body in a National Heritage place; permanently damage or obscure rock art or other cultural or ceremonial features with World Heritage values.	National Heritage places with natural heritage values: <i>Values associated with geology or landscapes</i>	Rare	Moderate	Low	<ul style="list-style-type: none"> Refer to ID#3 (Section 9.2.3) and ID#2 (Section 9.2.2). These sections will mitigate water quality issues and possible stability of waterways, which could cause damage to areas of cultural significance or World Heritage Values to be impacted by the Project. 	Minor	Very Low
Introduce noise, odours, pollutants or other intrusive elements with substantial, long-term or permanent impacts on relevant values.	National Heritage places with natural heritage values: <i>Wilderness, aesthetic, or other rare or unique environment values</i>	Rare	Moderate	Low	<ul style="list-style-type: none"> Refer to ID#1 (Section 9.2.1) and ID#2 (Section 9.2.3). These sections will mitigate water quality issues, sediment and erosion that could be developed from the Project. 	Minor	Very Low
Result in a substantial change in air quality or water quality (including temperature) which may adversely impact biodiversity, ecological health or integrity or social amenity or human health.	Great Barrier Reef Marine Park: <i>Significant Impact Criteria</i>	Rare	Moderate	Low	<ul style="list-style-type: none"> Refer to ID#1 (Section 9.2.1) and ID#3 (Section 9.2.3). These sections will mitigate water quality issues, sediment and erosion that could be developed from the Project. 	Minor	Very Low
Result in persistent organic chemicals, heavy metals, or other potentially harmful chemicals accumulating in the marine environment such that biodiversity, ecological integrity, social amenity or human health may be adversely affected.	Great Barrier Reef Marine Park: <i>Significant Impact Criteria</i>	Rare	Moderate	Low	<ul style="list-style-type: none"> Refer to ID#1 (Section 9.2.1). These sections will mitigate water quality issues that could be developed from the Project. 	Minor	Very Low

Source: *Guidelines for a Draft Public Environment Report - EPBC 2024/10044 (the PER guidelines)*

A.2 THE REEF LONG-TERM SUSTAINABILITY PLAN 2021-25

Source: *The Reef 2050 Objectives and Goals 2021-2025* - <https://www.dceew.gov.au/sites/default/files/documents/reef-2050-objectives-goals-2021-2025.pdf>

Potential Impacts to Surface Water	Report Section	Mitigation Measures	Objective Compliance
Coral reef habitats maintain good condition and resilience	Reef 2050 Objectives and Goals 2021–2025 Objective 1	<ul style="list-style-type: none"> Supported by the use of upstream ESCP guidelines and ensuring mitigation of water quality risks upstream. Refer to ID#1 (Section 9.2.1) and ID#3 (Section 9.2.3). 	Objective targets met via the Project’s mitigations.
No loss of the extent of natural wetlands	Reef 2050 Objectives and Goals 2021–2025 Objective 3	<ul style="list-style-type: none"> Alterations of landforms caused by Project works will be performed to minimise alteration and ensure stabilisation in line with best practice ESCP guidelines. This will cause no loss of extent to natural wetlands downstream. Refer to ID#1 (Section 9.2.1) and ID#2 (Section 9.2.2). 	Objective targets met via the Project’s mitigations
Wetland condition is improved	Reef 2050 Objectives and Goals 2021–2025 Objective 4	<ul style="list-style-type: none"> By reducing sediment loads from the project and pollutants leaving the Project, downstream Wetland conditions will be improved. Refer to ID#1 (Section 9.2.1) and ID#3 (Section 9.2.3). 	Objective targets met via the Project’s mitigations
Populations of bioculturally important fish and invertebrate species are healthy	Reef 2050 Objectives and Goals 2021–2025 Objective 9	<ul style="list-style-type: none"> Supported by the use of upstream ESCP guidelines and ensuring mitigation of water quality risks upstream. Refer to ID#1 (Section 9.2.1) and ID#3 (Section 9.2.3). 	Objective targets met via the Project’s mitigations
Populations of fish and invertebrate species that are important for recreational, commercial and culturally based fisheries are healthy	Reef 2050 Objectives and Goals 2021–2025 Objective 10	<ul style="list-style-type: none"> Supported by the use of upstream ESCP guidelines and ensuring mitigation of water quality risks upstream. Refer to ID#1 (Section 9.2.1) and ID#3 (Section 9.2.3). 	Objective targets met via the Project’s mitigations
Uses of the Reef are ecologically sustainable as the system changes, in turn sustaining economic and social benefits	Reef 2050 Objectives and Goals 2021–2025 Objective 16	<ul style="list-style-type: none"> Mitigation practices ensure downstream water outcomes will be ecologically sustainable, for economic and social benefits. Refer to ID#1 (Section 9.2.1) and ID#3 (Section 9.2.3) 	Objective targets met via the Project’s mitigations
The quality of water is improved through increased effective land management practices in catchments	Reef 2050 Objectives and Goals 2021–2025 Goal 4	<ul style="list-style-type: none"> By reducing sediment loads from the project and pollutants leaving the Project, the downstream quality of water is improved. Refer to ID#1 (Section 9.2.1) and ID#3 (Section 9.2.3). 	Objective targets met via the Project’s mitigations
Integrated catchment-to-Reef management reduces cumulative impacts	Reef 2050 Objectives and Goals 2021–2025 Goal 5	<ul style="list-style-type: none"> Supported by the use of upstream mitigations using IECA guidelines, ensuring stream stability and mitigation of water quality risks upstream. Refer to ID#1 (Section 9.2.1), ID#2 (Section 9.2.2) and ID#3 (Section 9.2.3). 	Objective targets met via the Project’s mitigations
Biodiversity and heritage protection are enhanced, and ecosystem resilience is supported through strengthened efforts to ensure water-based activities are sustainable	Reef 2050 Objectives and Goals 2021–2025 Goal 7	<ul style="list-style-type: none"> Supported by mitigation of impacts on downstream biodiversity and heritage by ensuring the use of upstream IECA guidelines and ensuring mitigation of water quality risks upstream. 	Objective targets met via the Project’s mitigations
Marine debris, rubbish pollution and at-sea disposal of waste is reduced	Reef 2050 Objectives and Goals 2021–2025 Goal 12	<ul style="list-style-type: none"> Supported by the use of upstream IECA guidelines and ensuring mitigation of water quality risks upstream. 	Objective targets met via the Project’s mitigations
Comprehensive monitoring, evaluation and reporting support informed and agile management responses	Reef 2050 Objectives and Goals 2021–2025 Goal 21	<ul style="list-style-type: none"> Comprehensive monitoring of erosion run-off, stream stability and riparian health, and water quality impacts to align with ID#1 (Section 9.2.1), ID#2 (Section 9.2.2) and ID#3 (Section 9.2.3). 	Objective targets met via the Project’s mitigations

A.3 REEF 2050 WATER QUALITY IMPROVEMENT PLAN

Table A.1 Regional Water Quality Targets

Source: Reef 2050 Water Quality Improvement Plan (2017-2022)

Region	Dissolved inorganic nitrogen		Fine sediment		Particulate nutrients			
					Particulate phosphorus		Particulate nitrogen	
	tonnes	% reduction	kilotonnes	% reduction	tonnes	% reduction	tonnes	% reduction
Cape York	MCL	MCL	23	5	14	5	48	5
Wet Tropics	1700	60	240	25	360	30	850	25
Burdekin	820	60	890	30	490	25	800	25
Mackay Whitsunday	630	70	130	20	150	20	310	20
Fitzroy	MCL	MCL	410	25	430	20	760	15
Burnett Mary	470	55	240	20	210	20	590	20

Table A.2 End-of-catchment anthropogenic water quality targets for the Reef catchments by 2025 and relative priorities for water quality improvement

Source: Reef 2050 Water Quality Improvement Plan -

https://www.reefplan.qld.gov.au/__data/assets/pdf_file/0017/46115/reef-2050-water-quality-improvement-plan-2017-22.pdf

Region	Catchment/ Basin	Area (ha)	Targets								Pesticide target to protect min 99% of aquatic species at end-of-catchment
			Dissolved inorganic nitrogen		Fine sediment		Particulate phosphorus		Particulate nitrogen		
			tonnes	% reduction	kilo-tonnes	% reduction	tonnes	% reduction	tonnes	% reduction	
Fitzroy	Styx River	301,340	MCL	MCL	MCL	MCL	MCL	MCL	MCL	MCL	
	Shoalwater Creek	360,180	MCL	MCL	MCL	MCL	MCL	MCL	MCL	MCL	
	Waterpark Creek	183,650	MCL	MCL	MCL	MCL	MCL	MCL	MCL	MCL	
	Fitzroy River	14,254,470	MCL	MCL	390	30	380	30	640	30	
	Calliope River	224,060	MCL	MCL	15	30	54	30	107	30	
	Boyne River	249,630	MCL	MCL	6	40	5	40	9	40	
Burnett Mary	Baffle Creek	408,470	16	50	11	20	15	20	33	20	
	Kolan River	290,450	34	50	6	20	5	20	14	20	
	Burnett River	3,319,540	150	70	85	20	29	20	68	20	
	Burrum River	337,170	93	50	3	20	3	20	8	20	
	Mary River	946,580	180	50	130	20	160	20	470	20	



Table A.3 REEF 2050 Objectives and Compliance

Objectives	Report Section	Mitigation Measures	Water Quality Target - Compliance
Meet water quality Targets for the Fitzroy Region	Reef 2050 Water Quality Improvement Plan (2017-2022) - Table 1. Regional Water Quality Targets	Meet the water quality targets of the Fitzroy Region. Refer to ID#3 (Section 9.2.3 and 9.3.2)	Comply - Water quality objectives are met via the Project’s mitigation measures.
Meet water quality targets for the Calliope River Catchment within the Fitzroy Region.	Reef 2050 Water Quality Improvement Plan (2017-2022) - Table 2. End-of-catchment anthropogenic water quality targets for the Reef catchments by 2025 and relative priorities for water quality improvement	Meet water quality targets for the Calliope River Catchment within the Fitzroy Region. Refer to ID#4 (Section 9.2.3 and 9.3.2)	Comply - Water quality objectives are met via the Project’s mitigation measures.

APPENDIX B FLOOD MAPS

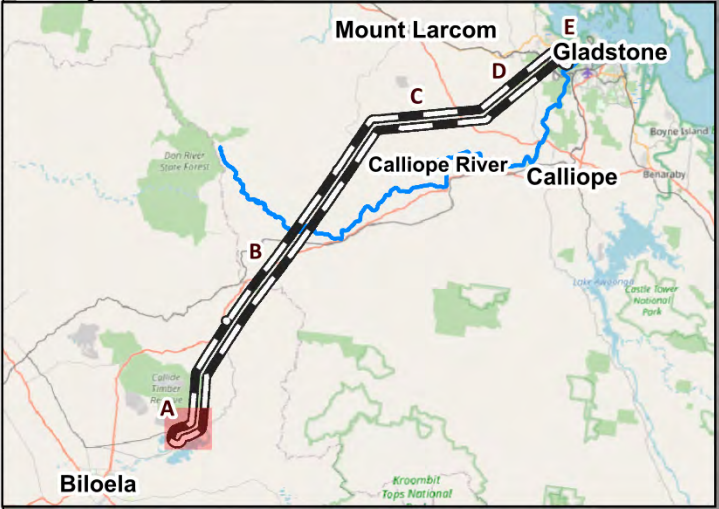
B.1 AERIAL IMAGERY OF CORRIDOR ALIGNMENT



- Legend
-  Project Area
 -  Towers
 -  1 m LiDAR Extent

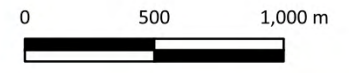





**Calvale to Calliope TL
Surface Water
Impact Assessment**

Aerial Imagery of Corridor

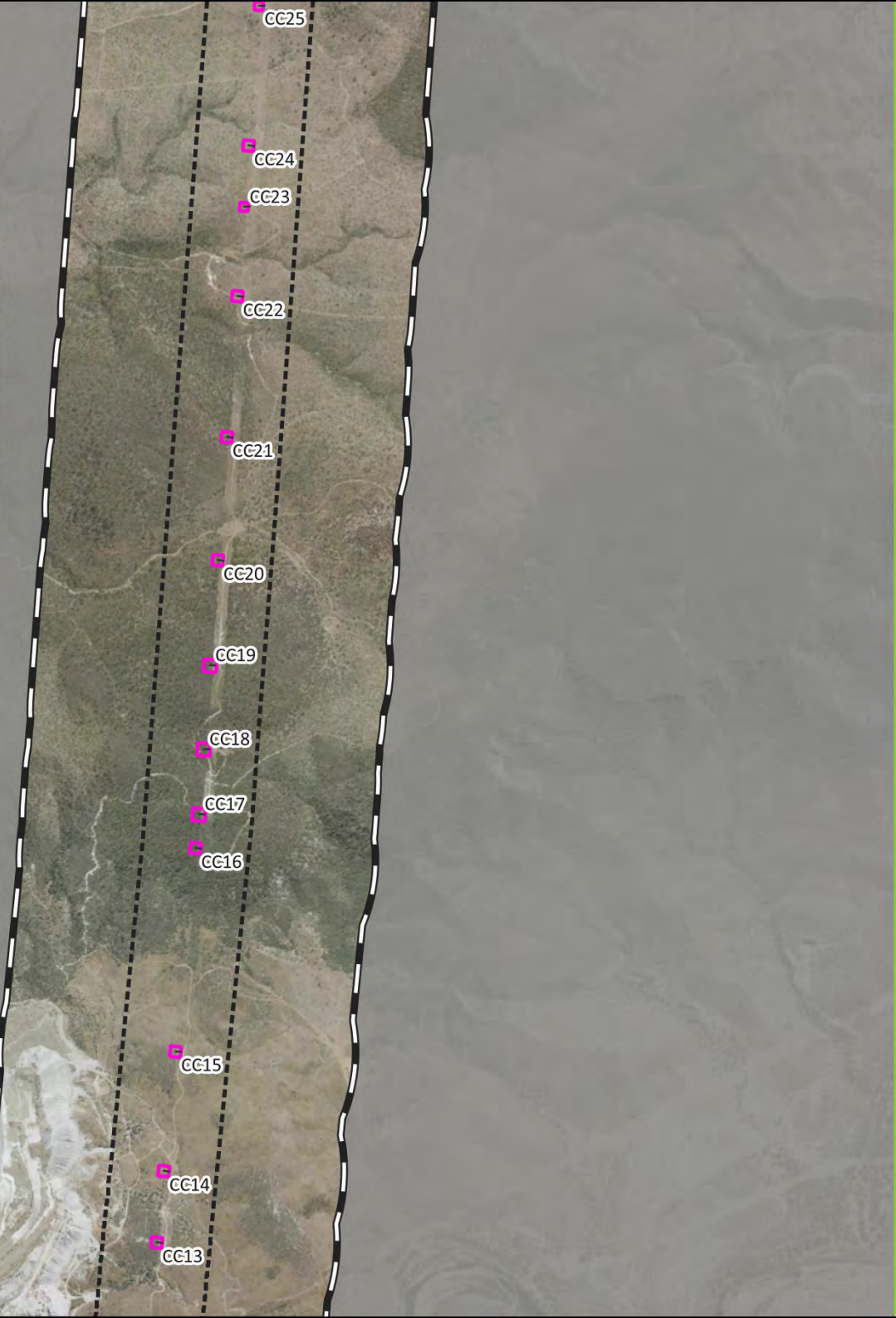
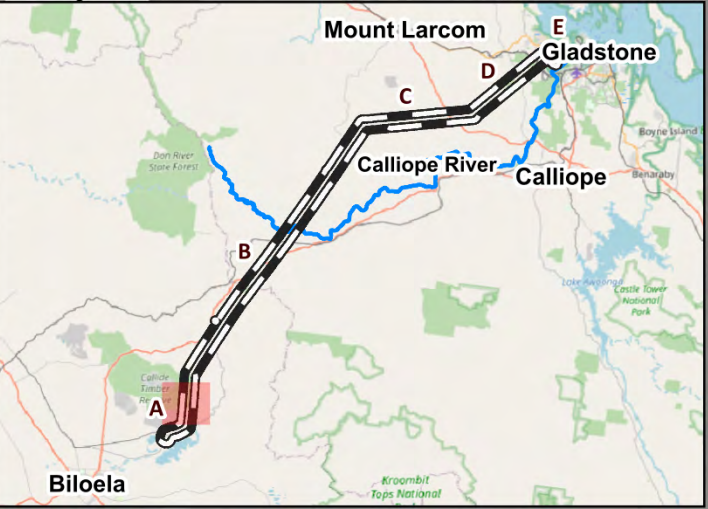

J:\2254-04_C2C-PER_GISAmendments\3_GIS\OGIS\2254-04-Alignment_Mapping.qgz (Figure_Alignment_Aerial_Imagery) [Exported: 06 March 2026]
Projection: EPSG:7856



- Legend
-  Project Area
 -  Towers
 -  1 m LiDAR Extent

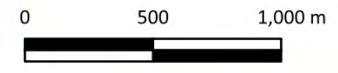



Calvale to Calliope TL Surface Water Impact Assessment

Aerial Imagery of Corridor

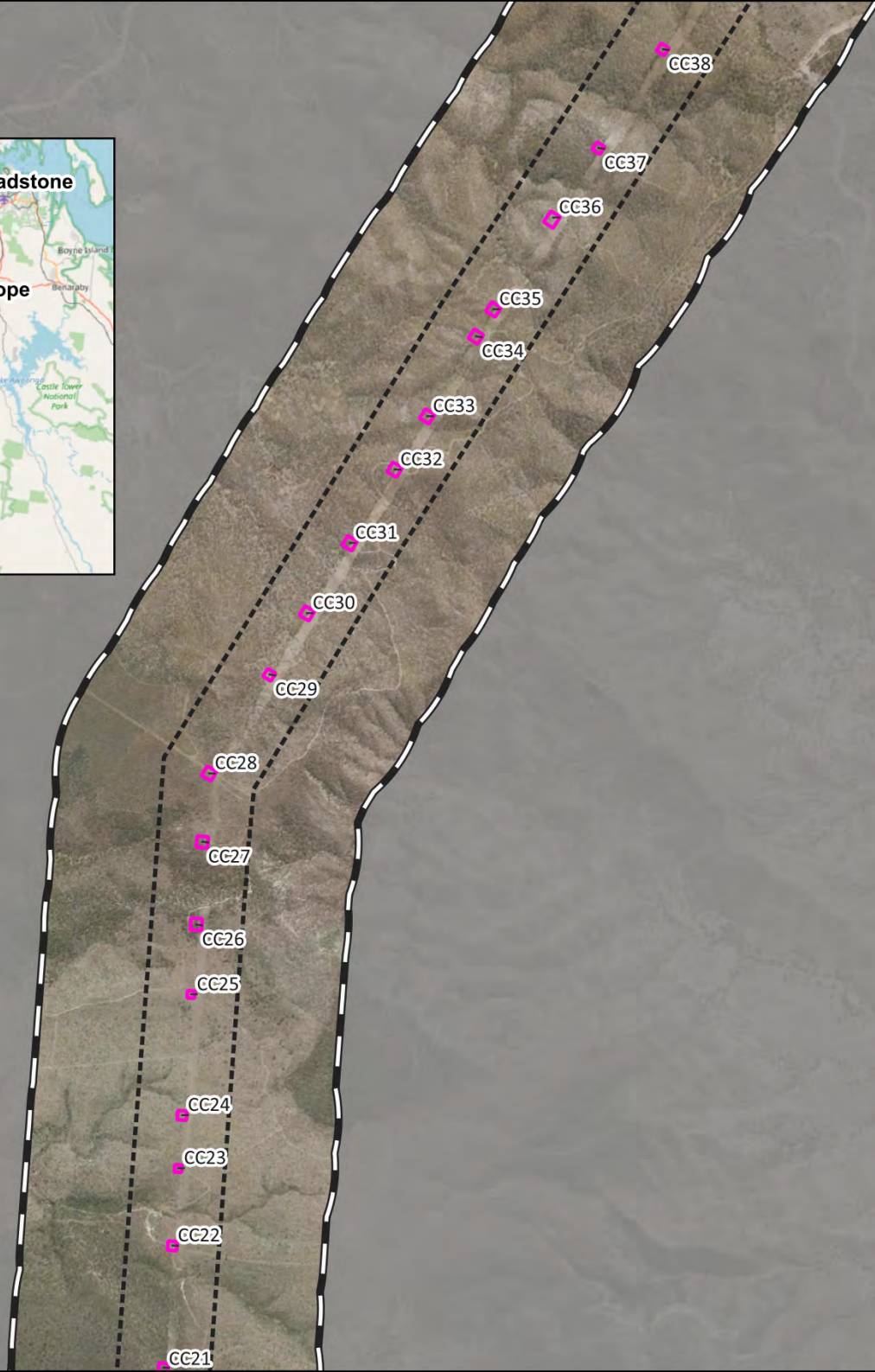



- Legend
-  Project Area
 -  Towers
 -  1 m LiDAR Extent

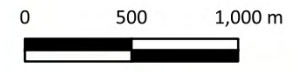

**Calvale to Calliope TL
Surface Water
Impact Assessment**

Aerial Imagery of Corridor



J:\2254-04_C2C-PER_GISAmendments\3_GIS\OGIS\2254-04-Alignment_Mapping.qgz (Figure_Aerial_Imagery) [Exported: 06 March 2026]
Projection: EPSG:7856

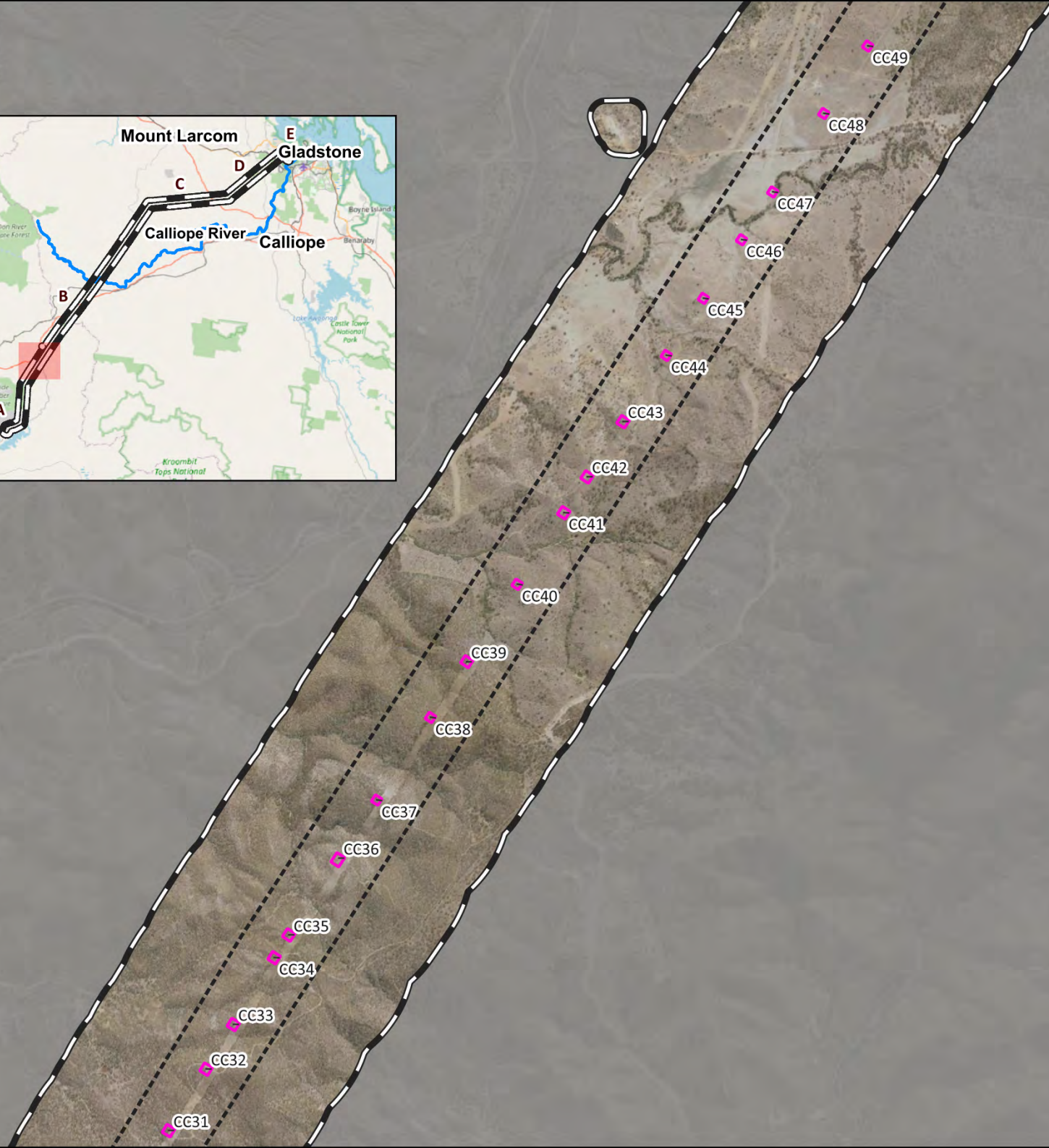

- Legend
- Project Area
 - Towers
 - 1 m LiDAR Extent

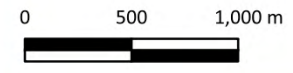



Calvale to Calliope TL Surface Water Impact Assessment

Aerial Imagery of Corridor



J:\2254-04_C2C-PER_GISAmendments\3_GIS\OGIS\2254-04-Alignment_Mapping.qgz (Figure_Aerial_Imagery) [Exported: 06 March 2026]



- Legend
-  Project Area
 -  Towers
 -  1 m LiDAR Extent

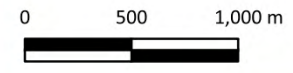

**Calvale to Calliope TL
Surface Water
Impact Assessment**

Aerial Imagery of Corridor



Projection: EPSG:7856



J:\2254-04_C2C-PER_GISAmendments\3_GIS\OGIS\2254-04-Alignment_Mapping.qgz (Figure_Aerial_Imagery) [Exported: 06 March 2026]
Projection: EPSG:7856



- Legend
- Project Area
 - Towers
 - 1 m LiDAR Extent

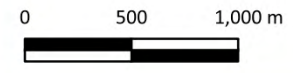

Calvale to Calliope TL Surface Water Impact Assessment

Aerial Imagery of Corridor



J:\2254-04_C2C-PER_GISAmendments\3_GIS\OGIS\2254-04-Alignment_Mapping.qgz (Figure_Aerial_Imagery) [Exported: 06 March 2026]
Projection: EPSG:7856

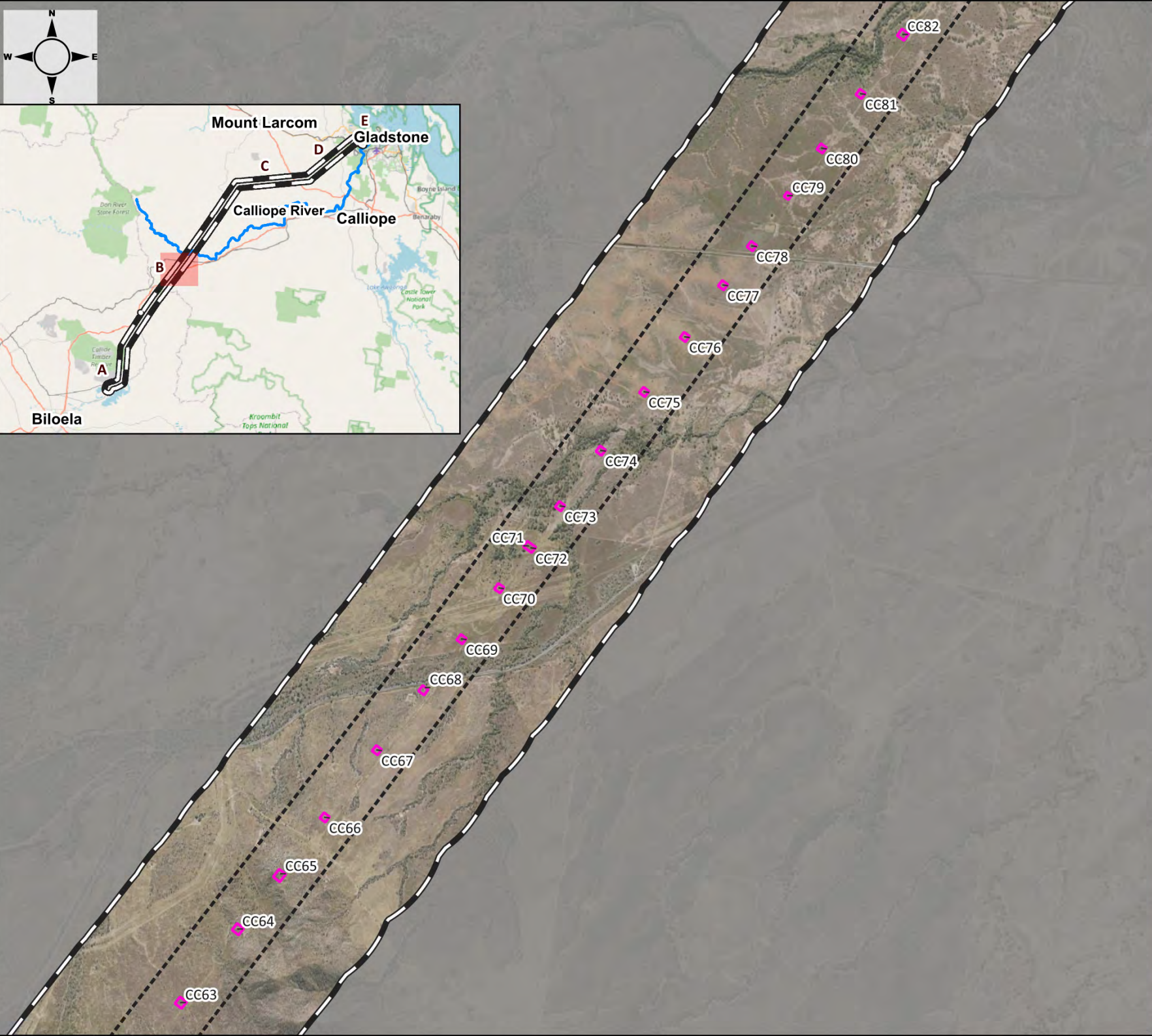
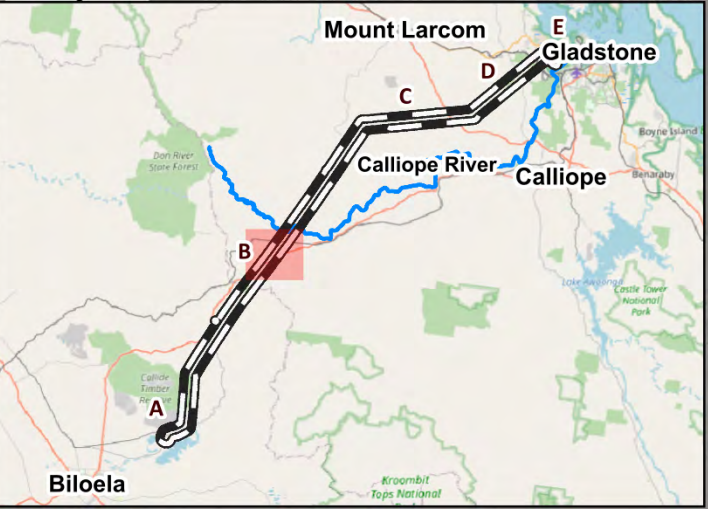

- Legend
- Project Area
 - Towers
 - 1 m LiDAR Extent

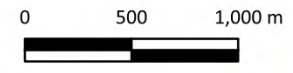

Calvale to Calliope TL Surface Water Impact Assessment

Aerial Imagery of Corridor



J:\2254-04_C2C-PER_GISA\Amendments\3_GIS\OGIS\2254-04-Alignment_Mapping.qgz (Figure_Aerial_Imagery) [Exported: 06 March 2026]
Projection: EPSG:7856



- Legend
- Project Area
 - Towers
 - 1 m LiDAR Extent

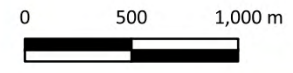



Calvale to Calliope TL Surface Water Impact Assessment

Aerial Imagery of Corridor

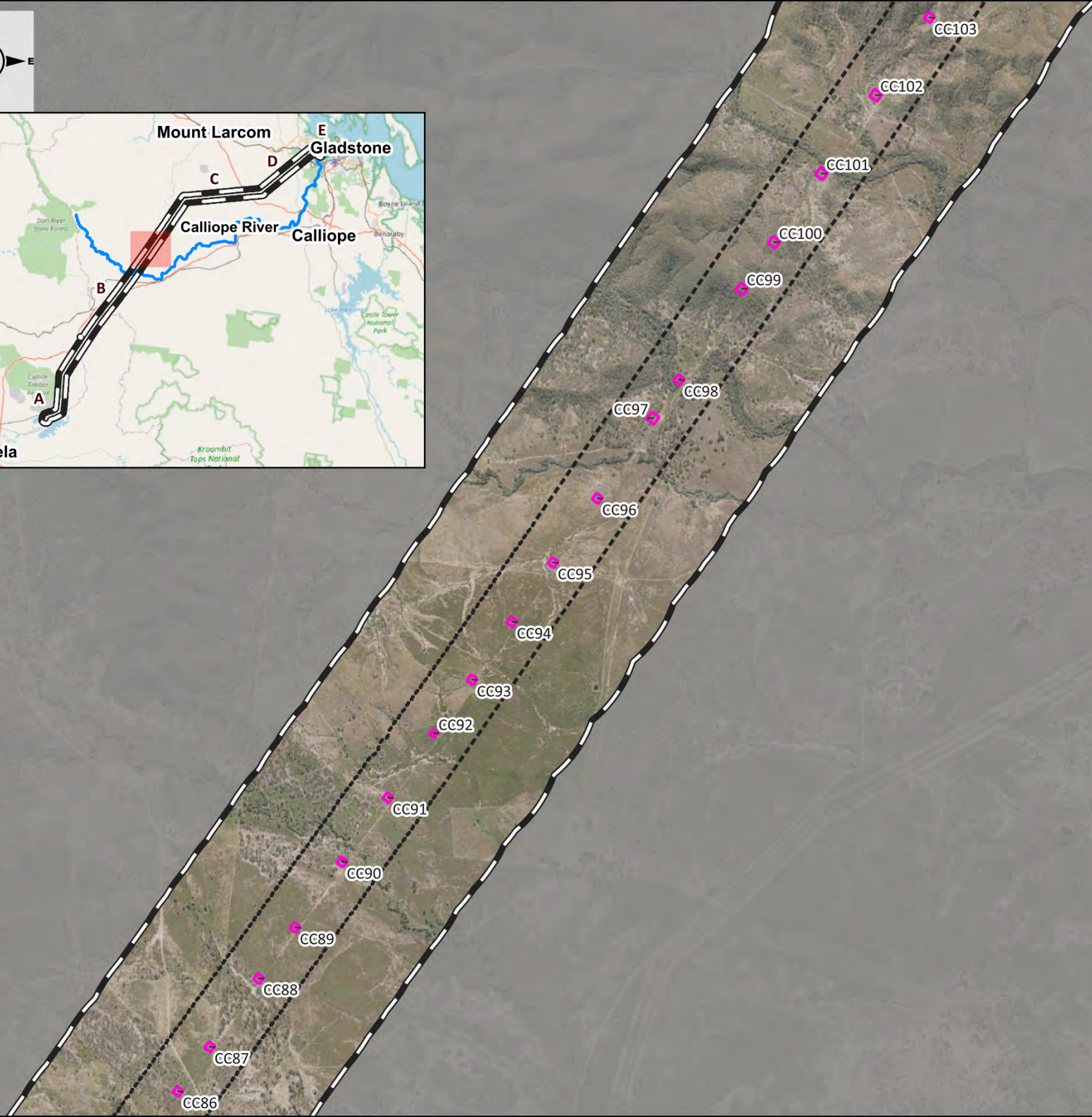
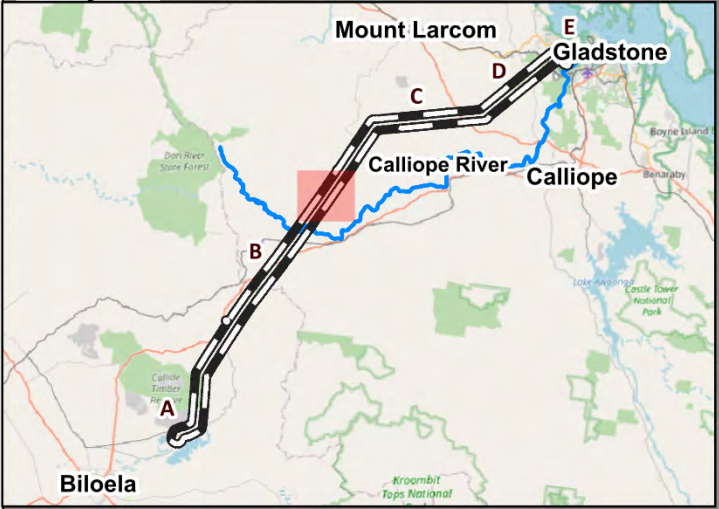



- Legend
-  Project Area
 -  Towers
 -  1 m LiDAR Extent

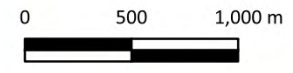





**Calvale to Calliope TL
Surface Water
Impact Assessment**

Aerial Imagery of Corridor

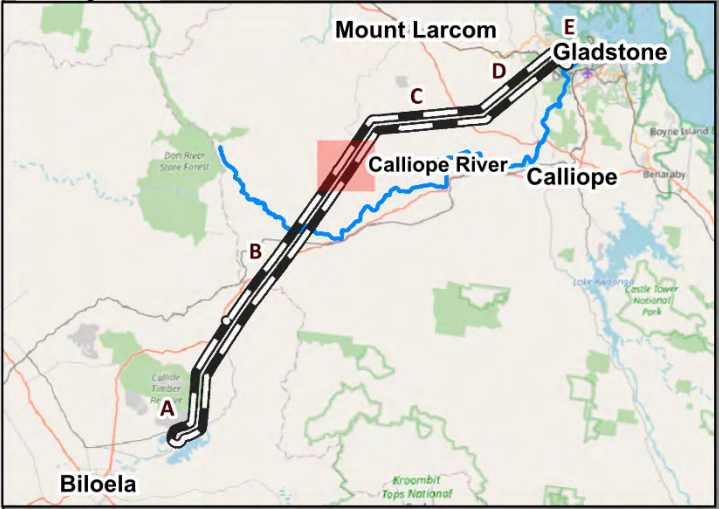

J:\2254-04_C2C-PER_GISAmendments\3_GIS\OGIS\2254-04-Alignment_Mapping.qgz (Figure_Aerial_Imagery) (Exported: 06 March 2026)



- Legend
-  Project Area
 -  Towers
 -  1 m LiDAR Extent

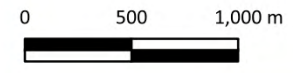

**Calvale to Calliope TL
Surface Water
Impact Assessment**

Aerial Imagery of Corridor



Projection: EPSG:7856

J:\2254-04_C2C-PER_GISAmendments\3_GIS\OGIS\2254-04-Alignment_Mapping.qgz (Figure_Alignment_Aerial_Imagery) [Exported: 06 March 2026]
Projection: EPSG:7856



- Legend
- Project Area
 - Towers
 - 1 m LiDAR Extent

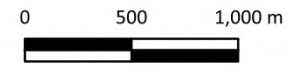



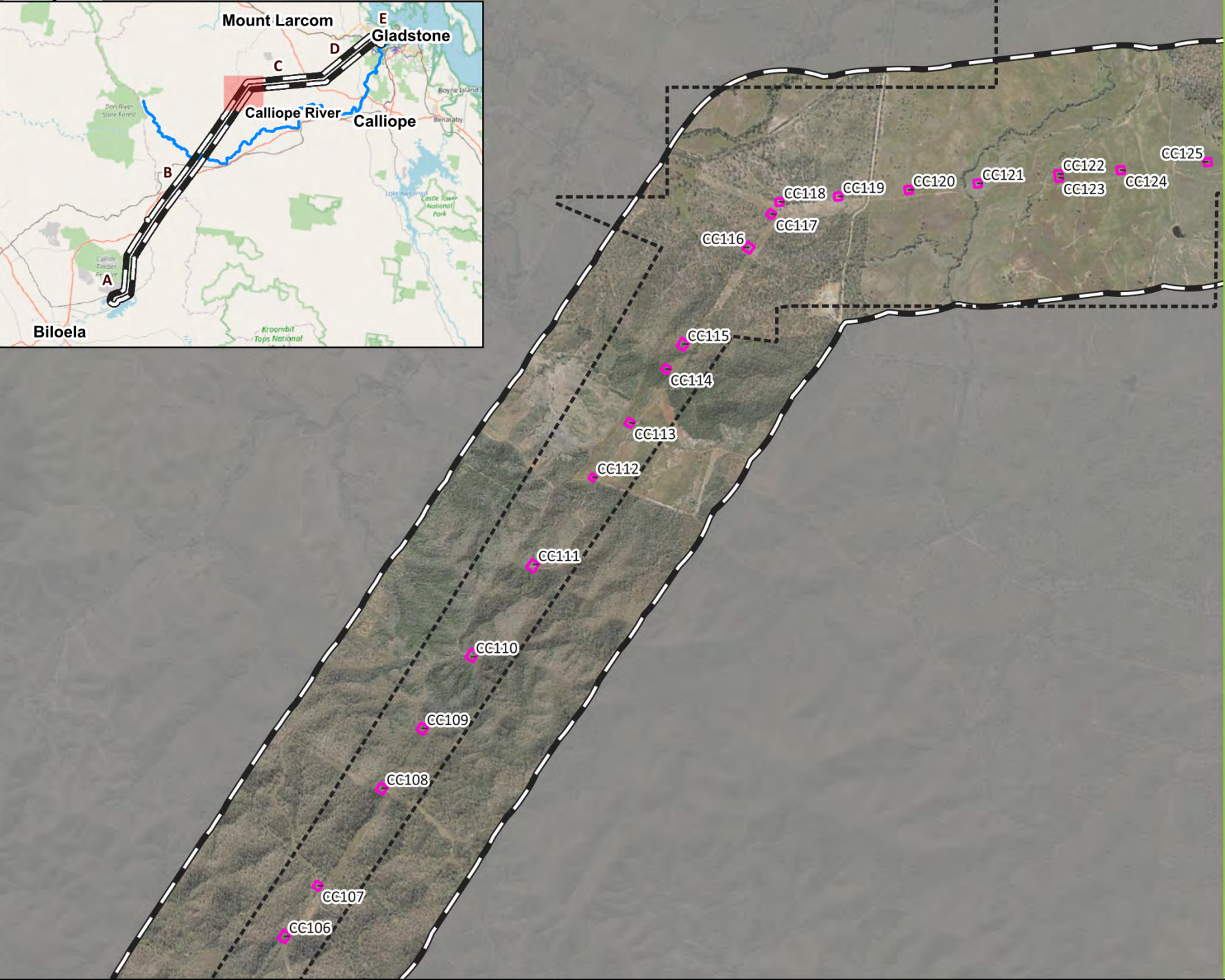

Calvale to Calliope TL Surface Water Impact Assessment

Aerial Imagery of Corridor

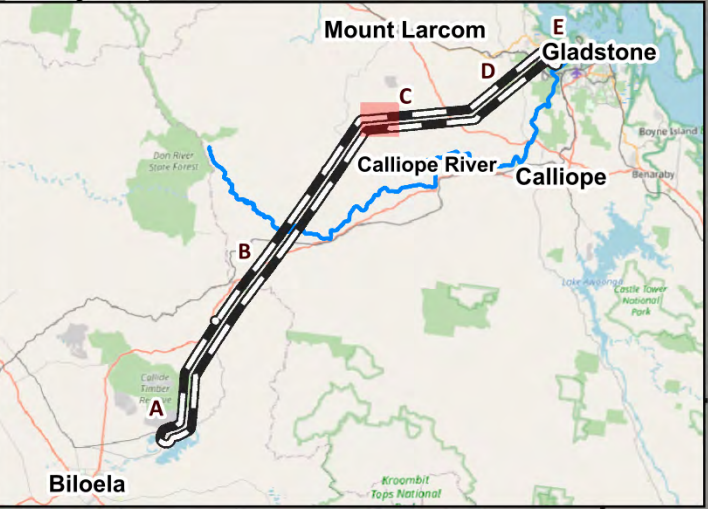

J:\2254-04_C2C-PER_GISA\amendments\3_GIS\GIS\2254-04-Alignment_Mapping.qdz (Figure_Aerial_Imagery) (Exported: 06 March 2026)
Projection: EPSG:7856



- Legend
-  Project Area
 -  Towers
 -  1 m LiDAR Extent

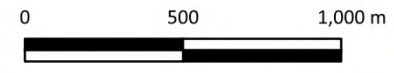
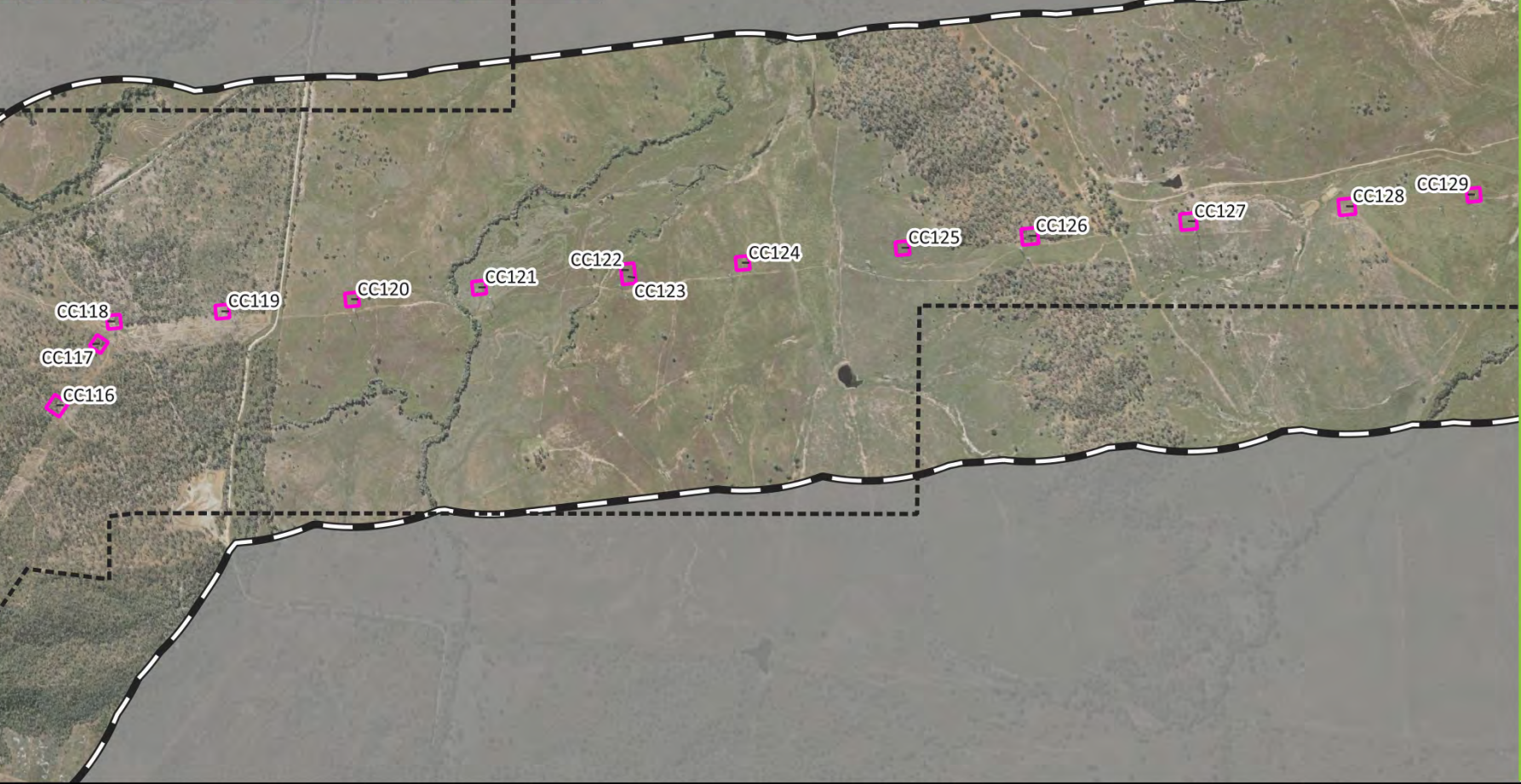

Calvale to Calliope TL Surface Water Impact Assessment

Aerial Imagery of Corridor



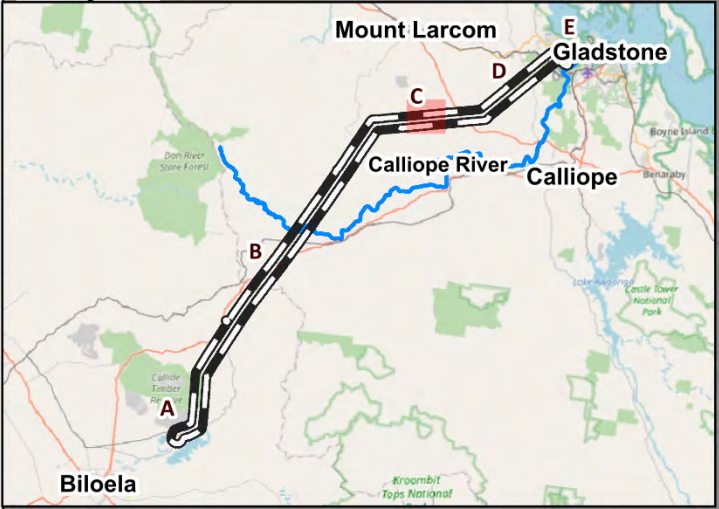

- Legend
- Project Area
 - Towers
 - 1 m LiDAR Extent

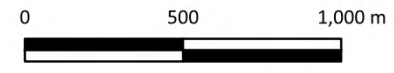
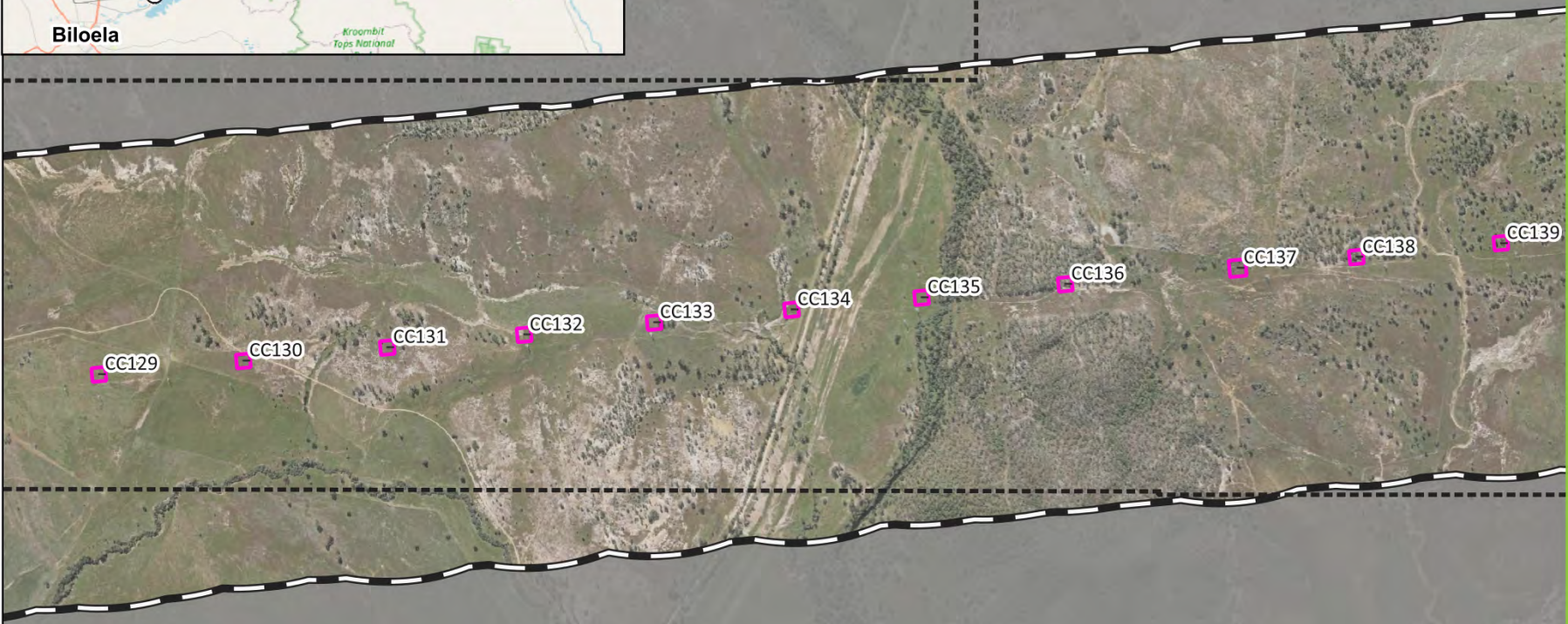

**Calvale to Calliope TL
Surface Water
Impact Assessment**

Aerial Imagery of Corridor



WATER +
ENVIRONMENT

J:\2254-04_C2C-PER_GISA\Amendments\3_GIS\OGIS\2254-04-Alignment_Mapping.qgz (Figure_Aerial_Imagery) (Exported: 06 March 2026)
Projection: EPSG:7856

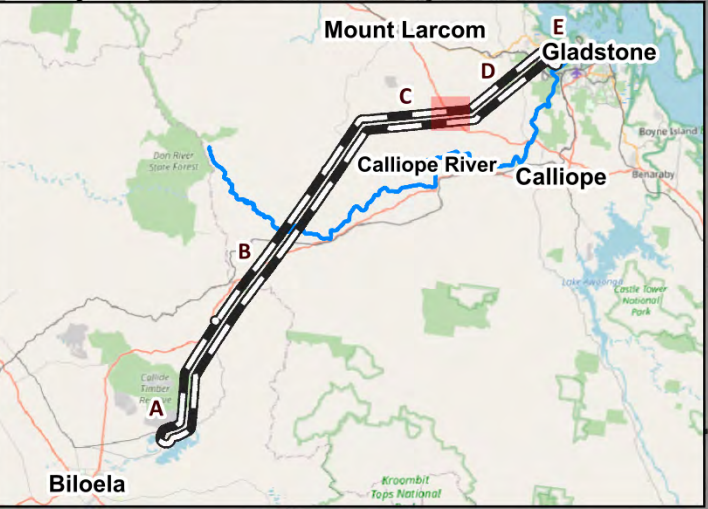

- Legend
- Project Area
 - Towers
 - 1 m LiDAR Extent

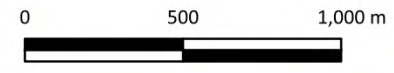
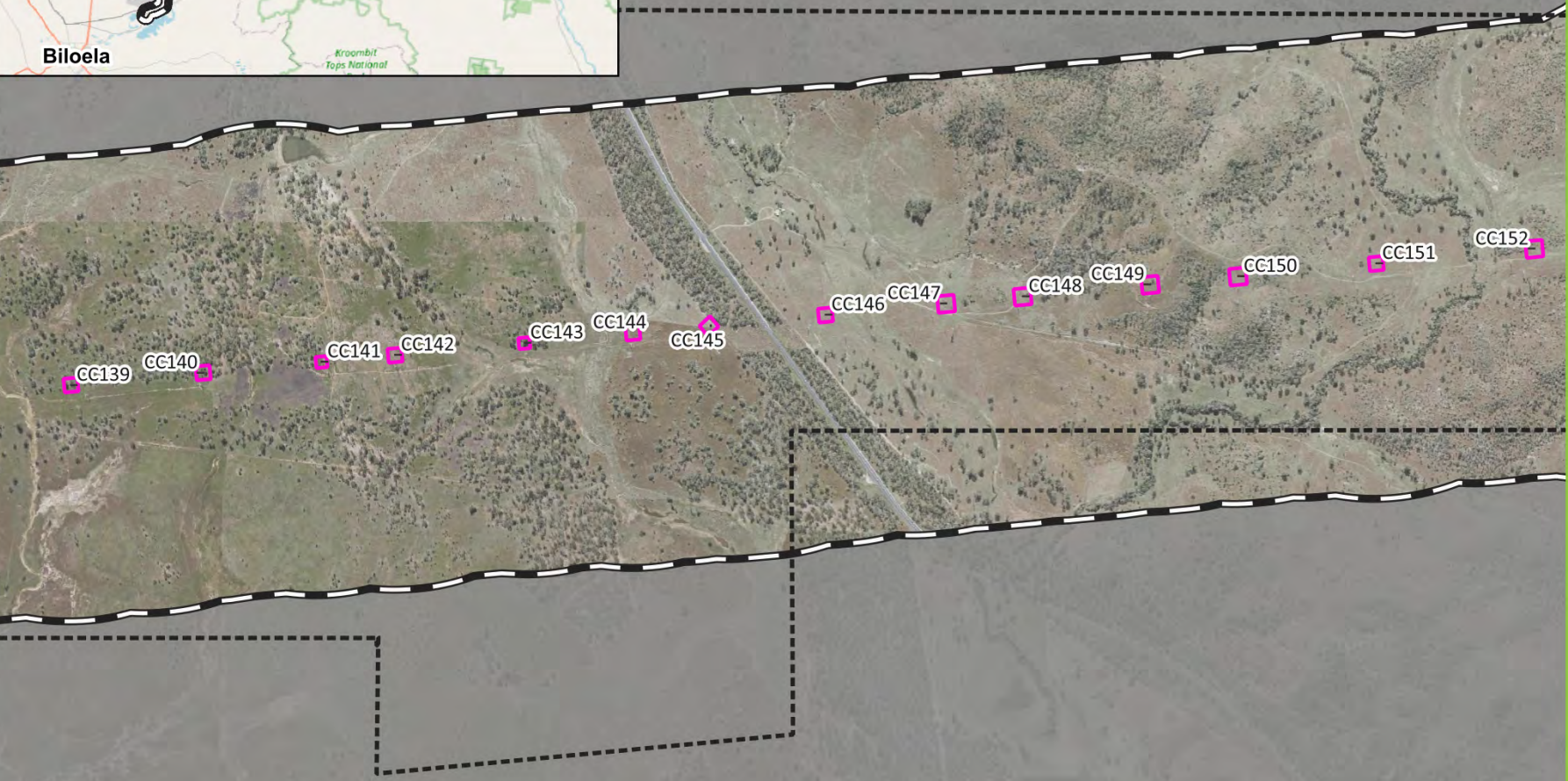



Calvale to Calliope TL Surface Water Impact Assessment

Aerial Imagery of Corridor

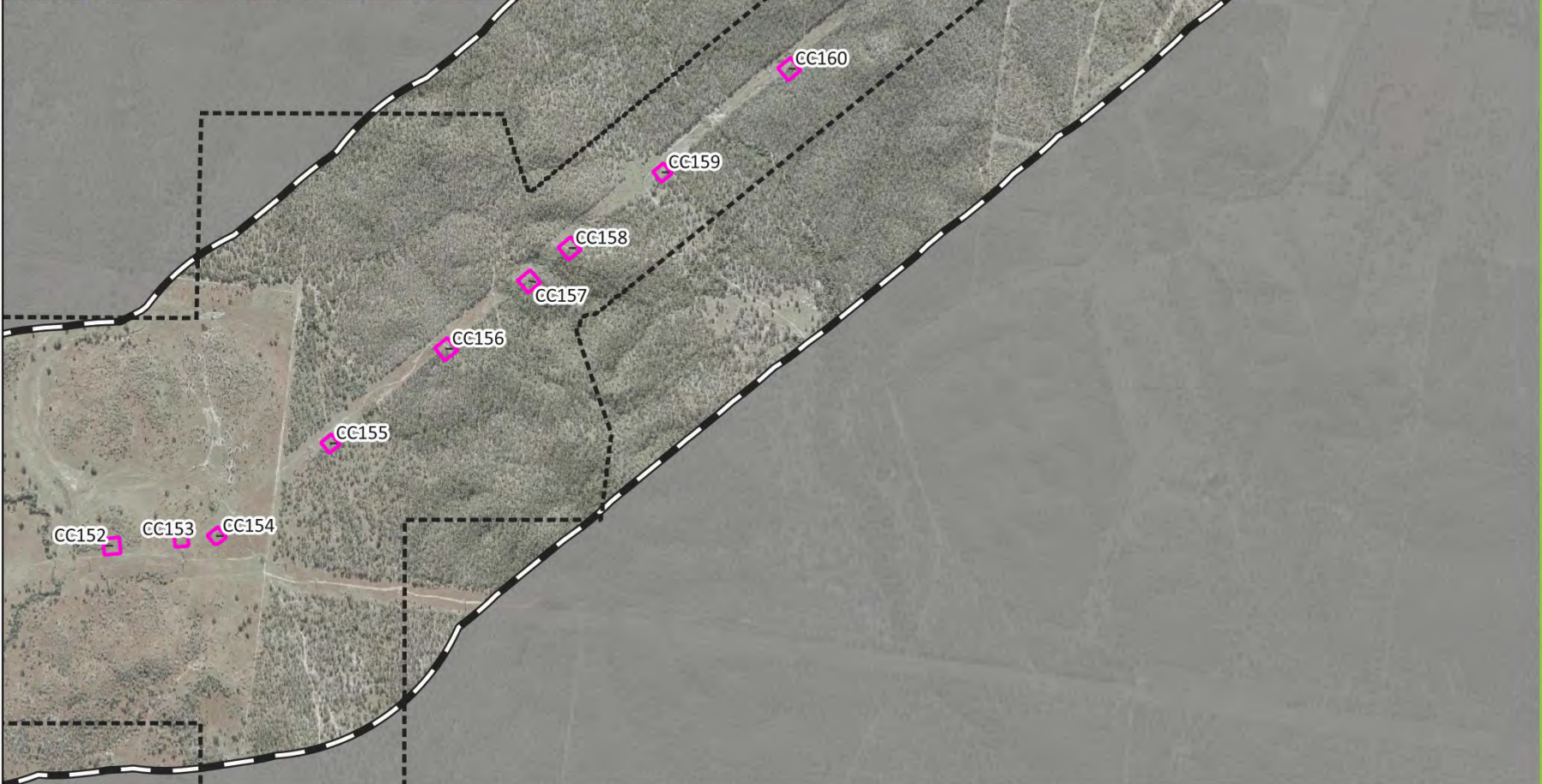
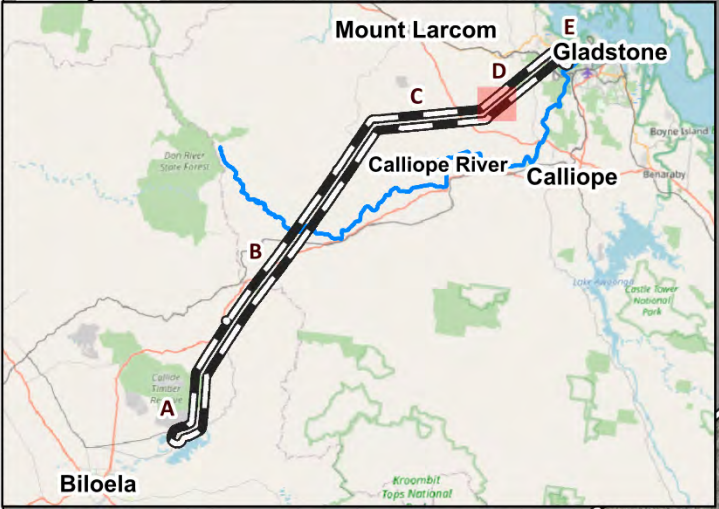



- Legend
-  Project Area
 -  Towers
 -  1 m LiDAR Extent

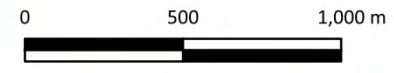

**Calvale to Calliope TL
Surface Water
Impact Assessment**

Aerial Imagery of Corridor



J:\2254-04_C2C-PER_GISAmendments\3_GIS\OGIS\2254-04-Alignment_Mapping.qdz (Figure_Alignment_Aerial_Imagery) [Exported: 06 March 2026]
Projection: EPSG:7856



- Legend
- Project Area
 - Towers
 - 1 m LiDAR Extent

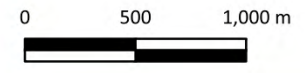

Calvale to Calliope TL Surface Water Impact Assessment

Aerial Imagery of Corridor



J:\2254-04_C2C-PER_GIS\Amendments\3_GIS\OGIS\2254-04-Alignment_Mapping.qgz (Figure_Aerial_Imagery) [Exported: 06 March 2026]
Projection: EPSG:7856



- Legend
- Project Area
 - Towers
 - 1 m LiDAR Extent



Calvale to Calliope TL Surface Water Impact Assessment

Aerial Imagery of Corridor



J:\2254-04_C2C-PER_GISAmendments\3_GIS\OGIS\2254-04-Alignment_Mapping.qdz (Figure_Aerial_Imagery) [Exported: 06 March 2026]
Projection: EPSG:7856



- Legend
- Project Area
 - Towers
 - 1 m LiDAR Extent



Calvale to Calliope TL Surface Water Impact Assessment

Aerial Imagery of Corridor



B.2 REGIONAL FLOOD MAPPING – CURRENT CLIMATE

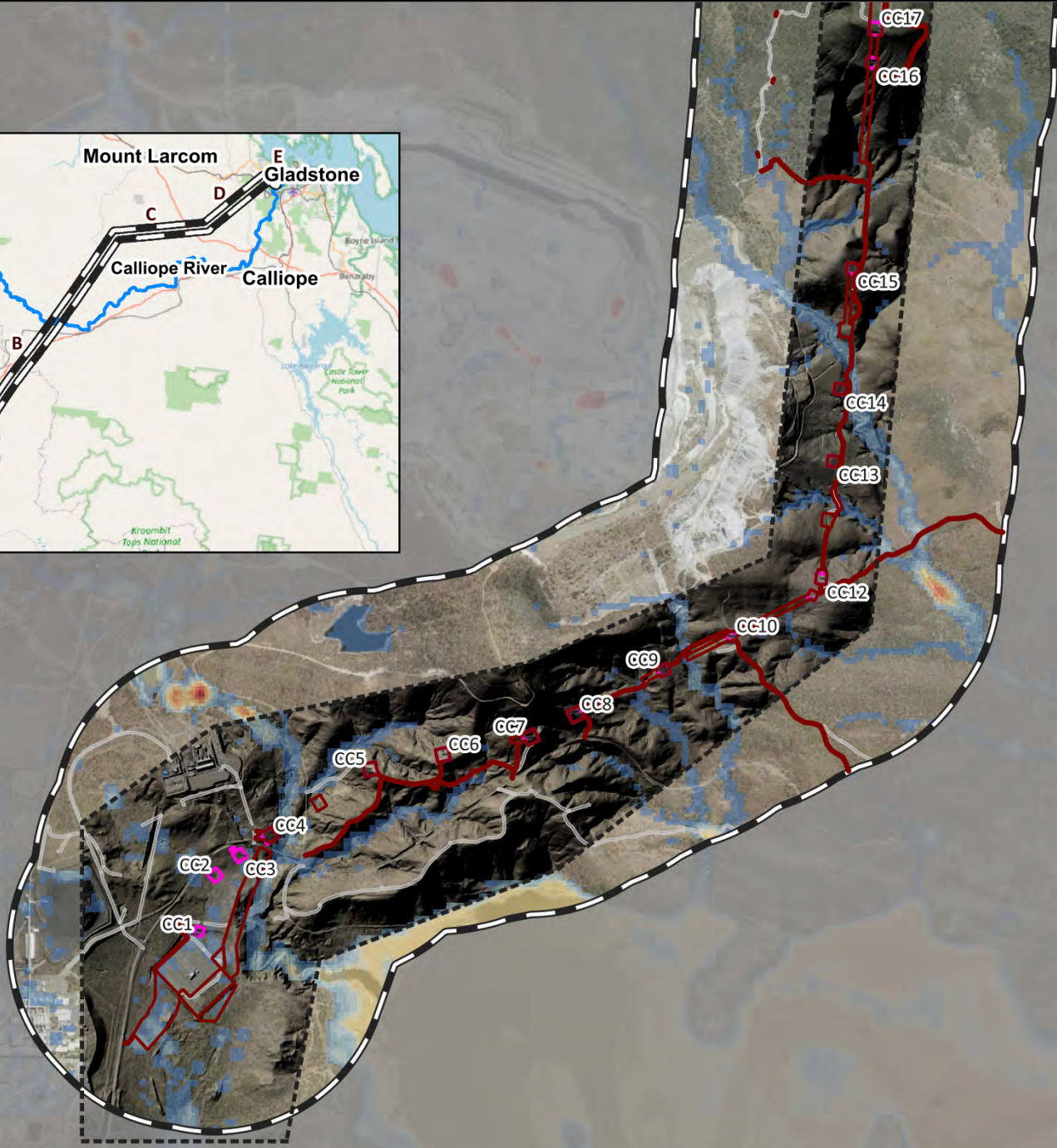

- Legend**
- Project Area
 - Towers
 - 1 m LiDAR Extent
 - Disturbance Footprint
 - Indicative Access Tracks

- Flood depth (m)**
- up to 0.25 m
 - 0.25 to 0.5 m
 - 0.5 to 1.0 m
 - 1.0 to 1.5 m
 - 1.5 to 2.0 m
 - 2.0 to 2.5 m
 - 2.5 to 3.0 m
 - 3.0 to 3.5 m
 - 3.5 to 4.0 m
 - 4.0 to 4.5 m
 - > 4.5 m

Modelling results are based on the best available elevation resolution: Copernicus. The available LiDAR data indicates areas where the elevation and therefore hydraulic model are inconsistent with local survey. All model results should be considered indicative and subject to broader survey validation.

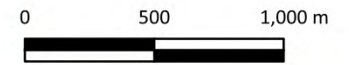

Calvale to Calliope TL Surface Water Impact Assessment

10% AEP Results
Page 1/18

J:\2254-04_C2C-PER_GISAmendments\3_GIS\QGIS\2254-04-Alignment_Mapping.qgz (Figure_Alignment_Depth_10p) (Exported: 06 March 2026)
Projection: EPSG:7856

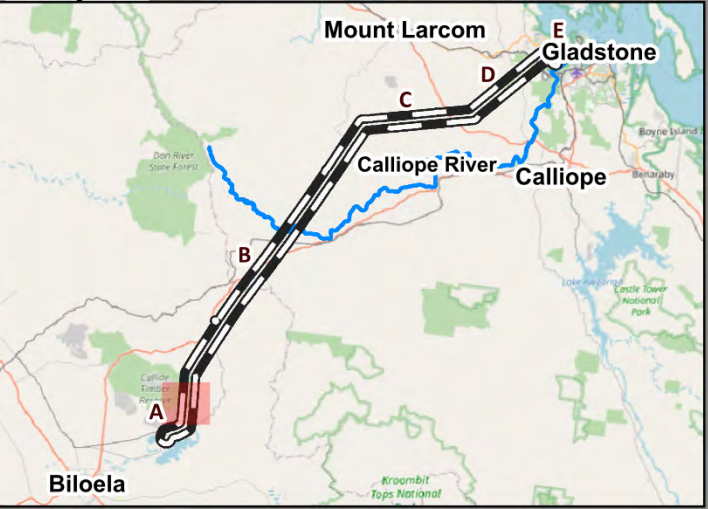

- Legend**
- Project Area
 - Towers
 - 1 m LiDAR Extent
 - Disturbance Footprint
 - Indicative Access Tracks

- Flood depth (m)**
- up to 0.25 m
 - 0.25 to 0.5 m
 - 0.5 to 1.0 m
 - 1.0 to 1.5 m
 - 1.5 to 2.0 m
 - 2.0 to 2.5 m
 - 2.5 to 3.0 m
 - 3.0 to 3.5 m
 - 3.5 to 4.0 m
 - 4.0 to 4.5 m
 - > 4.5 m

Modelling results are based on the best available elevation resolution: Copernicus. The available LiDAR data indicates areas where the elevation and therefore hydraulic model are inconsistent with local survey. All model results should be considered indicative and subject to broader survey validation.

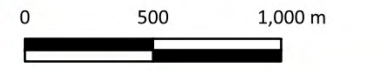

Calvale to Calliope TL Surface Water Impact Assessment

10% AEP Results
Page 2/18



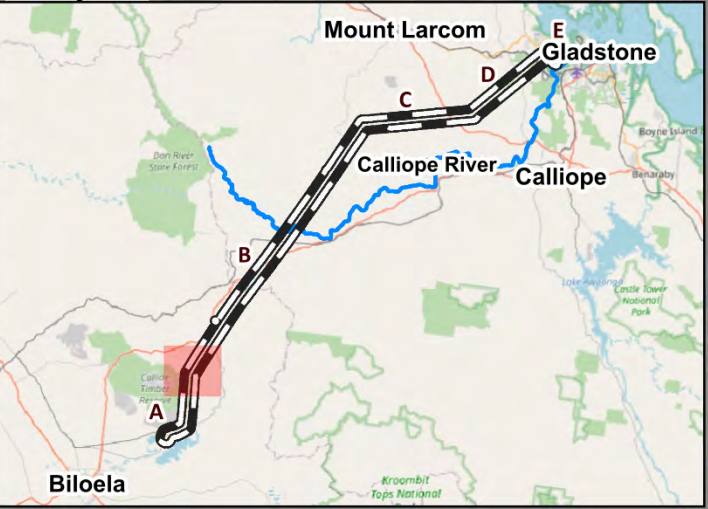

- Legend**
- Project Area
 - Towers
 - 1 m LiDAR Extent
 - Disturbance Footprint
 - Indicative Access Tracks

- Flood depth (m)**
- up to 0.25 m
 - 0.25 to 0.5 m
 - 0.5 to 1.0 m
 - 1.0 to 1.5 m
 - 1.5 to 2.0 m
 - 2.0 to 2.5 m
 - 2.5 to 3.0 m
 - 3.0 to 3.5 m
 - 3.5 to 4.0 m
 - 4.0 to 4.5 m
 - > 4.5 m

Modelling results are based on the best available elevation resolution: Copernicus. The available LiDAR data indicates areas where the elevation and therefore hydraulic model are inconsistent with local survey. All model results should be considered indicative and subject to broader survey validation.

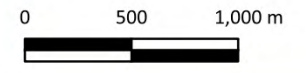

**Calvale to Calliope TL
Surface Water
Impact Assessment**

10% AEP Results
Page 3/18



J:\2254-04_C2C-PER_GISAmendments\3_GIS\GIS\2254-04-Alignment_Mapping_02\Figure_Alignment_Depth_10p (Exported: 06 March 2026)

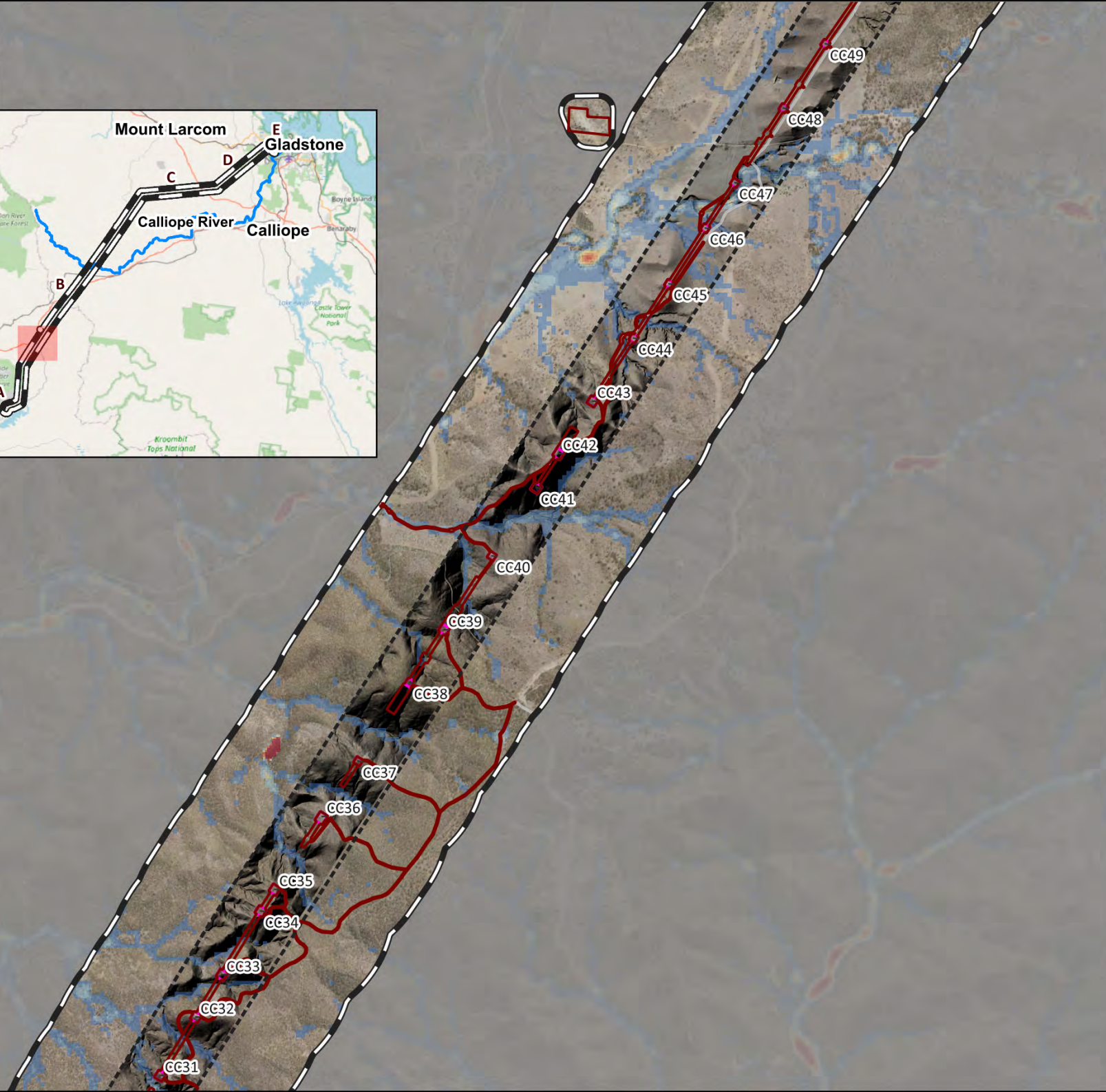

- Legend**
- Project Area
 - Towers
 - 1 m LiDAR Extent
 - Disturbance Footprint
 - Indicative Access Tracks

- Flood depth (m)**
- up to 0.25 m
 - 0.25 to 0.5 m
 - 0.5 to 1.0 m
 - 1.0 to 1.5 m
 - 1.5 to 2.0 m
 - 2.0 to 2.5 m
 - 2.5 to 3.0 m
 - 3.0 to 3.5 m
 - 3.5 to 4.0 m
 - 4.0 to 4.5 m
 - > 4.5 m

Modelling results are based on the best available elevation resolution: Copernicus. The available LiDAR data indicates areas where the elevation and therefore hydraulic model are inconsistent with local survey. All model results should be considered indicative and subject to broader survey validation.

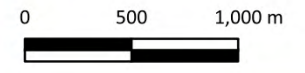

Calvale to Calliope TL Surface Water Impact Assessment

10% AEP Results
Page 4/18



WATER +
ENVIRONMENT

Projection: EPSG:7856

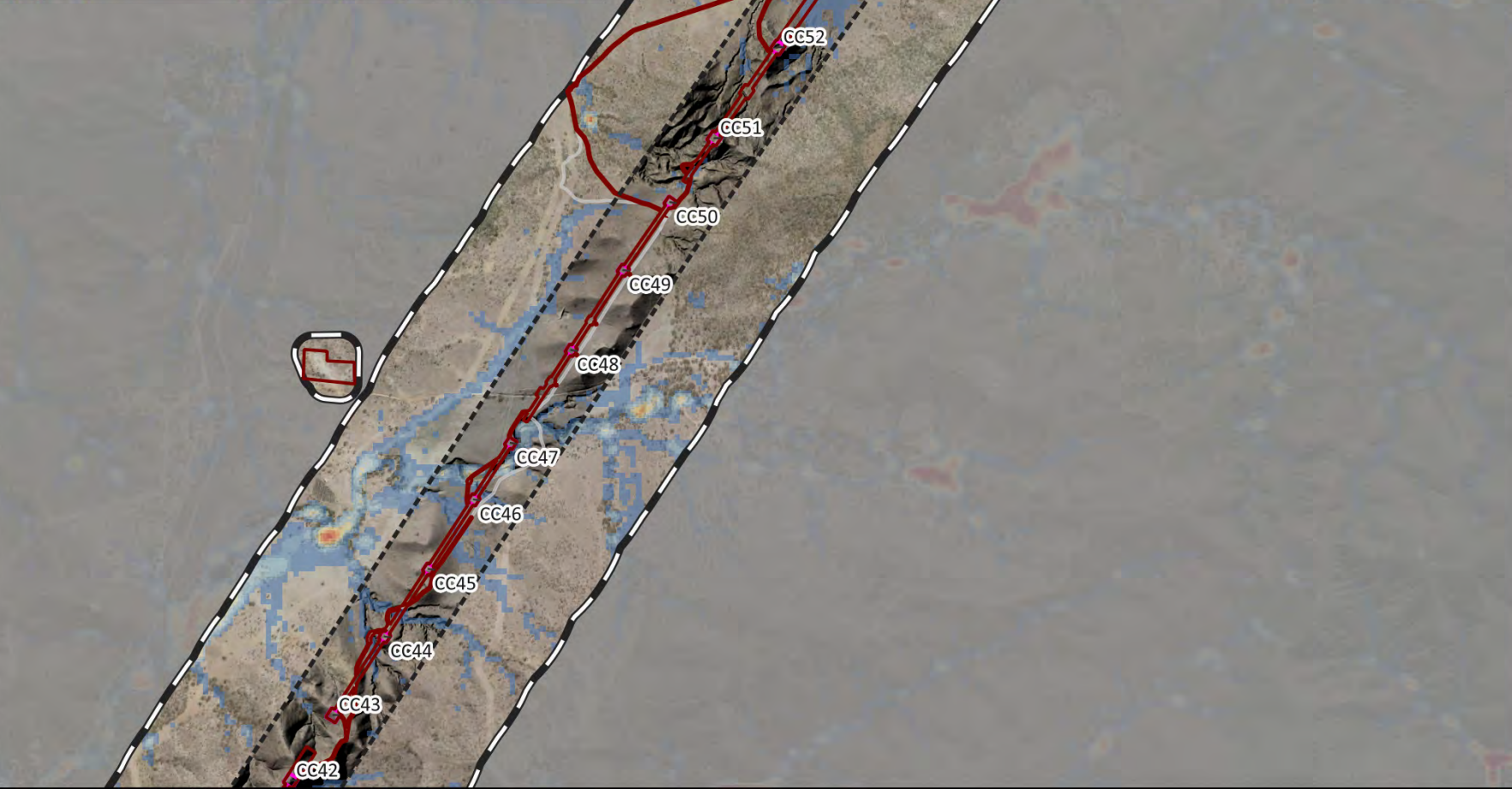

- Legend**
- Project Area
 - Towers
 - 1 m LiDAR Extent
 - Disturbance Footprint
 - Indicative Access Tracks

- Flood depth (m)**
- up to 0.25 m
 - 0.25 to 0.5 m
 - 0.5 to 1.0 m
 - 1.0 to 1.5 m
 - 1.5 to 2.0 m
 - 2.0 to 2.5 m
 - 2.5 to 3.0 m
 - 3.0 to 3.5 m
 - 3.5 to 4.0 m
 - 4.0 to 4.5 m
 - > 4.5 m

Modelling results are based on the best available elevation resolution: Copernicus. The available LiDAR data indicates areas where the elevation and therefore hydraulic model are inconsistent with local survey. All model results should be considered indicative and subject to broader survey validation.

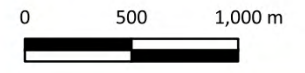

**Calvale to Calliope TL
Surface Water
Impact Assessment**

10% AEP Results
Page 5/18



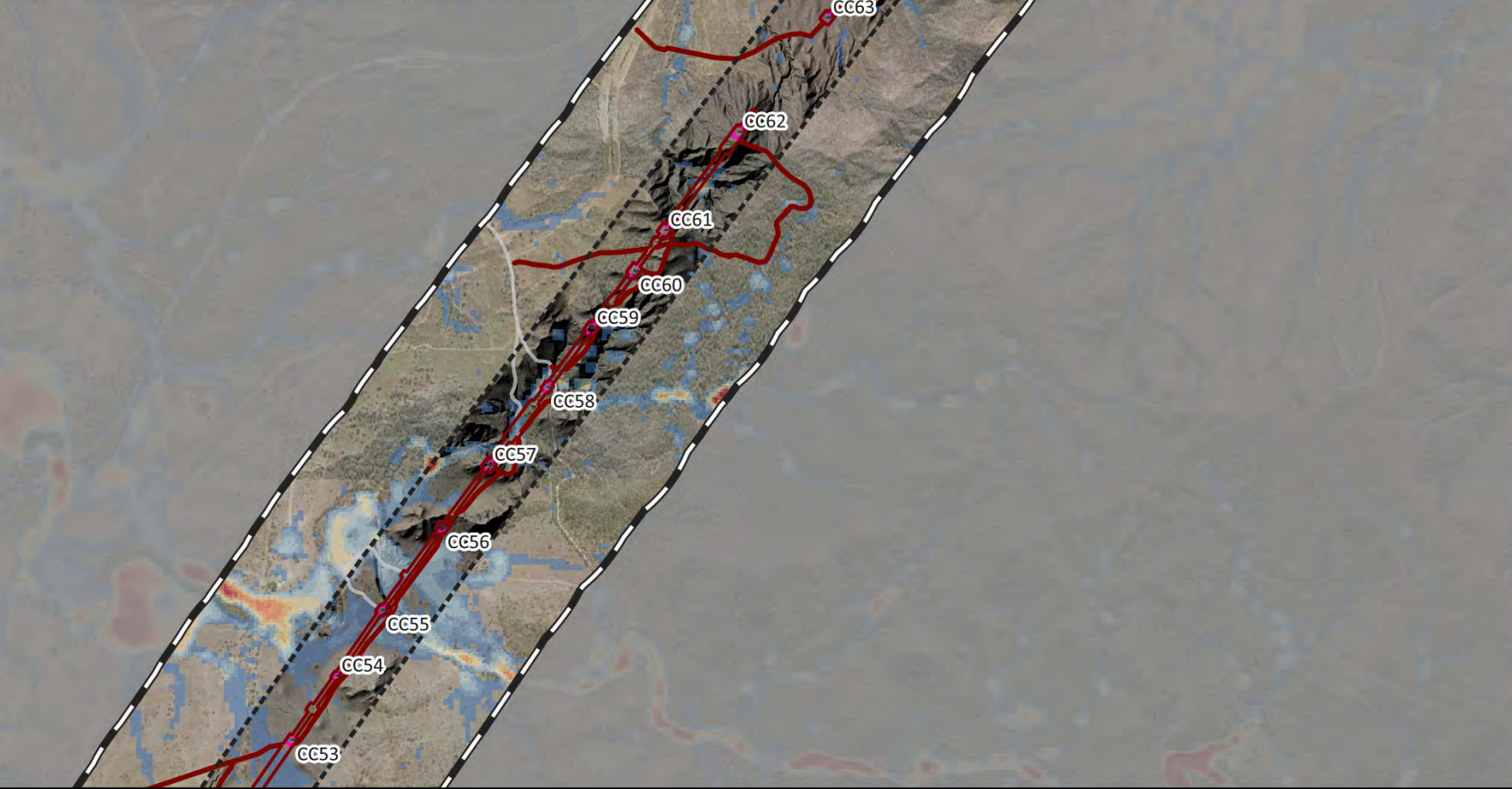

- Legend**
- Project Area
 - Towers
 - 1 m LiDAR Extent
 - Disturbance Footprint
 - Indicative Access Tracks

- Flood depth (m)**
- up to 0.25 m
 - 0.25 to 0.5 m
 - 0.5 to 1.0 m
 - 1.0 to 1.5 m
 - 1.5 to 2.0 m
 - 2.0 to 2.5 m
 - 2.5 to 3.0 m
 - 3.0 to 3.5 m
 - 3.5 to 4.0 m
 - 4.0 to 4.5 m
 - > 4.5 m

Modelling results are based on the best available elevation resolution: Copernicus. The available LiDAR data indicates areas where the elevation and therefore hydraulic model are inconsistent with local survey. All model results should be considered indicative and subject to broader survey validation.



**Calvale to Calliope TL
Surface Water
Impact Assessment**

10% AEP Results
Page 6/18



J:\2254-04_C2C-PER_GISAmendments\3_GIS\QGIS\2254-04-Alignment_Mapping_02\Figure_Alignment_Depth_10p (Exported: 06 March 2026)
Projection: EPSG:7856

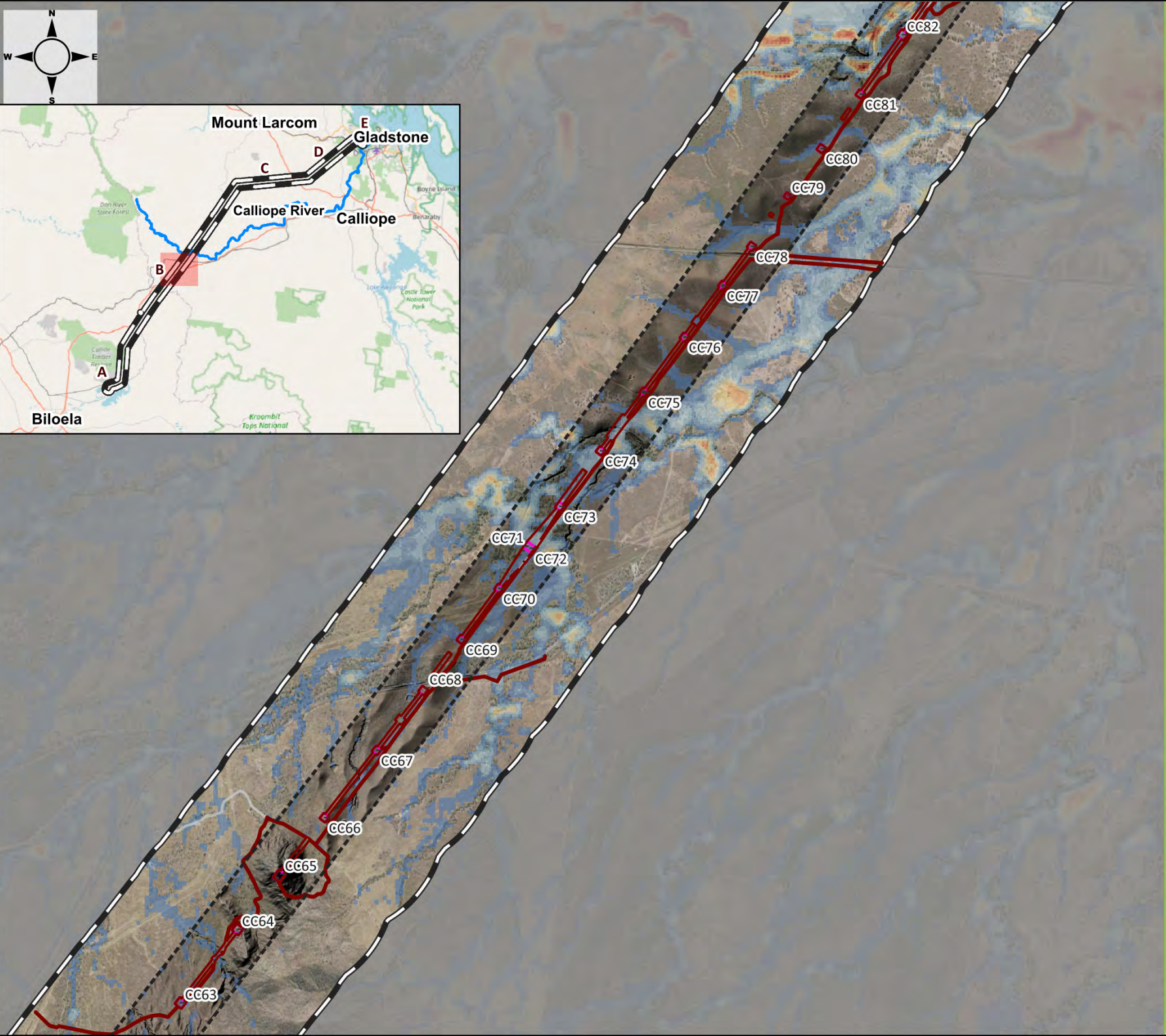
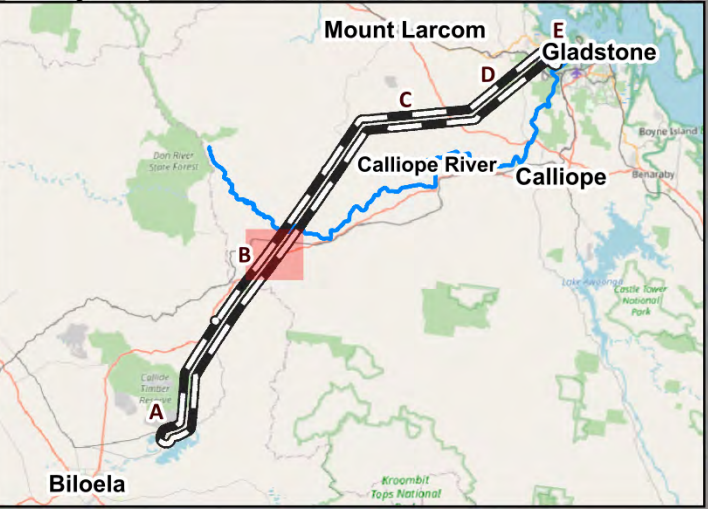

- Legend**
- Project Area
 - Towers
 - 1 m LiDAR Extent
 - Disturbance Footprint
 - Indicative Access Tracks

- Flood depth (m)**
- up to 0.25 m
 - 0.25 to 0.5 m
 - 0.5 to 1.0 m
 - 1.0 to 1.5 m
 - 1.5 to 2.0 m
 - 2.0 to 2.5 m
 - 2.5 to 3.0 m
 - 3.0 to 3.5 m
 - 3.5 to 4.0 m
 - 4.0 to 4.5 m
 - > 4.5 m

Modelling results are based on the best available elevation resolution: Copernicus. The available LiDAR data indicates areas where the elevation and therefore hydraulic model are inconsistent with local survey. All model results should be considered indicative and subject to broader survey validation.

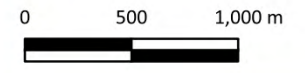

Calvale to Calliope TL Surface Water Impact Assessment

10% AEP Results
Page 7/18



J:\2254-04_C2C-PER_GISAmendments\3_GIS\GIS\2254-04-Alignment_Mapping\fig_10p | Exported: 06 March 2026
Projection: EPSG:7856



- Legend**
- Project Area
 - Towers
 - 1 m LiDAR Extent
 - Disturbance Footprint
 - Indicative Access Tracks

- Flood depth (m)**
- up to 0.25 m
 - 0.25 to 0.5 m
 - 0.5 to 1.0 m
 - 1.0 to 1.5 m
 - 1.5 to 2.0 m
 - 2.0 to 2.5 m
 - 2.5 to 3.0 m
 - 3.0 to 3.5 m
 - 3.5 to 4.0 m
 - 4.0 to 4.5 m
 - > 4.5 m

Modelling results are based on the best available elevation resolution: Copernicus. The available LiDAR data indicates areas where the elevation and therefore hydraulic model are inconsistent with local survey. All model results should be considered indicative and subject to broader survey validation.

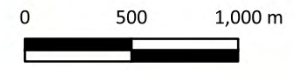

Calvale to Calliope TL Surface Water Impact Assessment

10% AEP Results
Page 8/18





- Legend**
- Project Area
 - Towers
 - 1 m LiDAR Extent
 - Disturbance Footprint
 - Indicative Access Tracks

- Flood depth (m)**
- up to 0.25 m
 - 0.25 to 0.5 m
 - 0.5 to 1.0 m
 - 1.0 to 1.5 m
 - 1.5 to 2.0 m
 - 2.0 to 2.5 m
 - 2.5 to 3.0 m
 - 3.0 to 3.5 m
 - 3.5 to 4.0 m
 - 4.0 to 4.5 m
 - > 4.5 m

Modelling results are based on the best available elevation resolution: Copernicus. The available LiDAR data indicates areas where the elevation and therefore hydraulic model are inconsistent with local survey. All model results should be considered indicative and subject to broader survey validation.

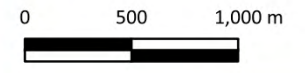

**Calvale to Calliope TL
Surface Water
Impact Assessment**

10% AEP Results
Page 9/18



J:\2254-04_C2C-PER_GISAmendments\3_GIS\QGIS\2254-04-Alignment_Mapping_02\Figure_Alignment_Depth_10p | Exported: 06 March 2026
Projection: EPSG:7856



- Legend**
- Project Area
 - Towers
 - 1 m LiDAR Extent
 - Disturbance Footprint
 - Indicative Access Tracks

- Flood depth (m)**
- up to 0.25 m
 - 0.25 to 0.5 m
 - 0.5 to 1.0 m
 - 1.0 to 1.5 m
 - 1.5 to 2.0 m
 - 2.0 to 2.5 m
 - 2.5 to 3.0 m
 - 3.0 to 3.5 m
 - 3.5 to 4.0 m
 - 4.0 to 4.5 m
 - > 4.5 m

Modelling results are based on the best available elevation resolution: Copernicus. The available LiDAR data indicates areas where the elevation and therefore hydraulic model are inconsistent with local survey. All model results should be considered indicative and subject to broader survey validation.



Calvale to Calliope TL Surface Water Impact Assessment

10% AEP Results
Page 10/18



J:\2254-04_C2C-PER_GISAmendments\3_GIS\GIS\2254-04-Alignment_Mapping.aprx (Figure_Alignment_Depth_10p) (Exported: 06 March 2026)
Projection: EPSG:7856

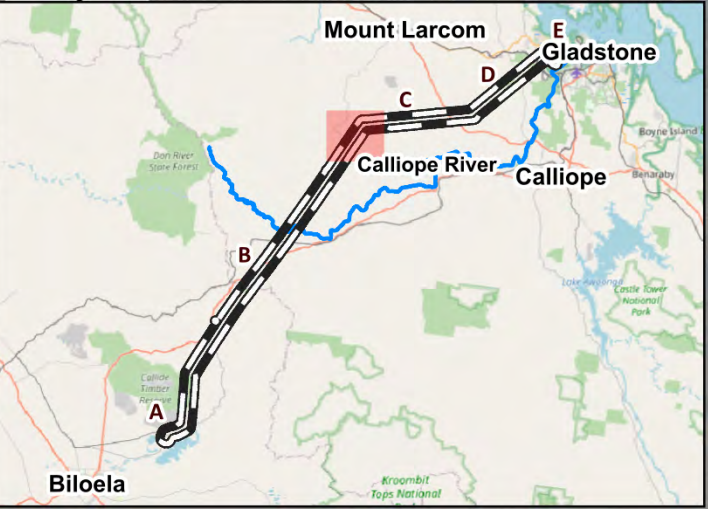

- Legend**
- Project Area
 - Towers
 - 1 m LiDAR Extent
 - Disturbance Footprint
 - Indicative Access Tracks

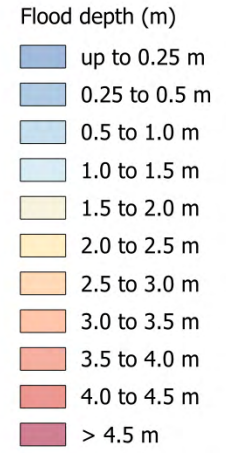

Modelling results are based on the best available elevation resolution: Copernicus. The available LiDAR data indicates areas where the elevation and therefore hydraulic model are inconsistent with local survey. All model results should be considered indicative and subject to broader survey validation.



Calvale to Calliope TL Surface Water Impact Assessment

10% AEP Results
Page 11/18



J:\2254-04_C2C-PER_GISAmendments\3_GIS\GIS\2254-04-Alignment_Mapping_02\Figure_Alignment_Depth_10p (Exported: 06 March 2026)
Projection: EPSG:7856

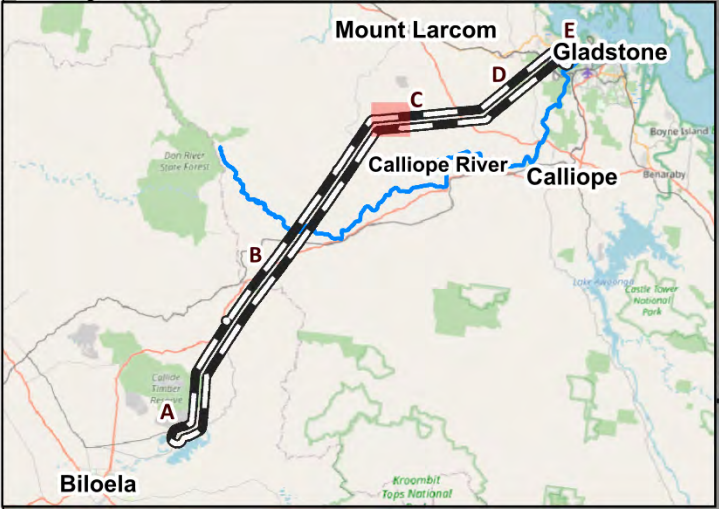

- Legend**
- Project Area
 - Towers
 - 1 m LiDAR Extent
 - Disturbance Footprint
 - Indicative Access Tracks

- Flood depth (m)**
- up to 0.25 m
 - 0.25 to 0.5 m
 - 0.5 to 1.0 m
 - 1.0 to 1.5 m
 - 1.5 to 2.0 m
 - 2.0 to 2.5 m
 - 2.5 to 3.0 m
 - 3.0 to 3.5 m
 - 3.5 to 4.0 m
 - 4.0 to 4.5 m
 - > 4.5 m

Modelling results are based on the best available elevation resolution: Copernicus. The available LiDAR data indicates areas where the elevation and therefore hydraulic model are inconsistent with local survey. All model results should be considered indicative and subject to broader survey validation.



Calvale to Calliope TL Surface Water Impact Assessment

10% AEP Results
Page 12/18



J:\2254-04_C2C-PER_GISAmendments\3_GIS\GIS\2254-04-Alignment_Mapping_02\Figure_Alignment_Depth_10p (Exported: 06 March 2026)

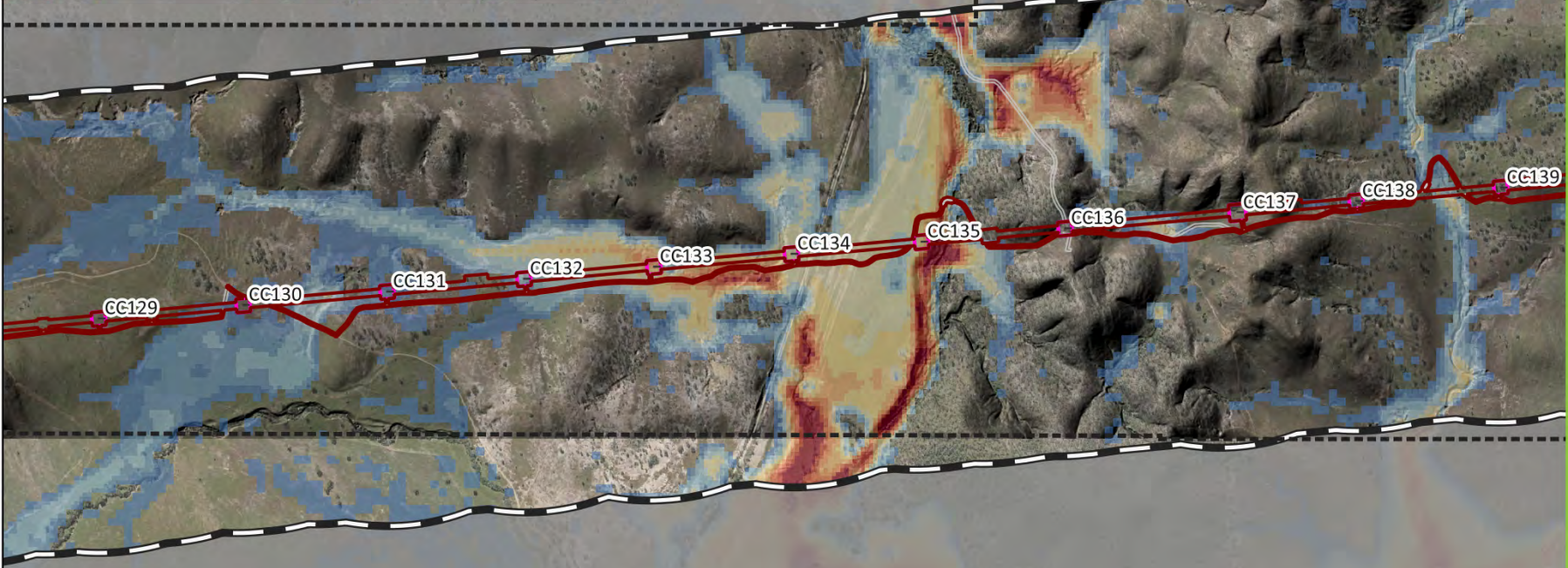
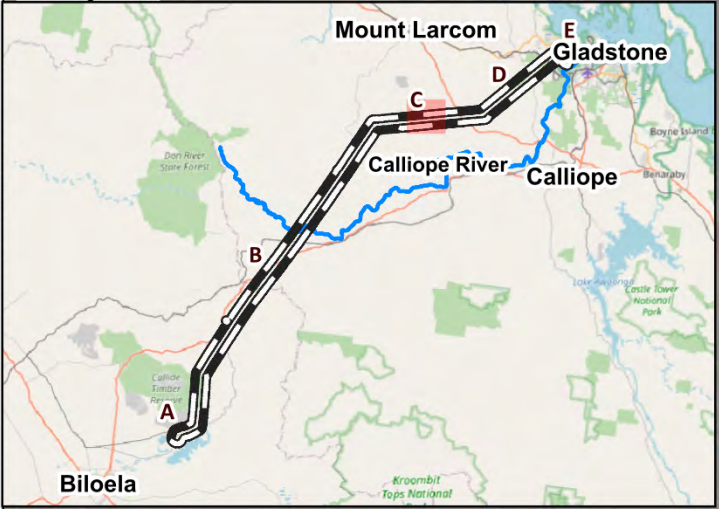

- Legend**
- Project Area
 - Towers
 - 1 m LiDAR Extent
 - Disturbance Footprint
 - Indicative Access Tracks

- Flood depth (m)**
- up to 0.25 m
 - 0.25 to 0.5 m
 - 0.5 to 1.0 m
 - 1.0 to 1.5 m
 - 1.5 to 2.0 m
 - 2.0 to 2.5 m
 - 2.5 to 3.0 m
 - 3.0 to 3.5 m
 - 3.5 to 4.0 m
 - 4.0 to 4.5 m
 - > 4.5 m

Modelling results are based on the best available elevation resolution: Copernicus. The available LiDAR data indicates areas where the elevation and therefore hydraulic model are inconsistent with local survey. All model results should be considered indicative and subject to broader survey validation.



**Calvale to Calliope TL
Surface Water
Impact Assessment**

10% AEP Results
Page 13/18



WATER + ENVIRONMENT

Projection: EPSG:7856

J:\2254-04_C2C-PER_GISAmendments\3_GIS\GIS\2254-04-Alignment_Mapping.dwg (Figure_Alignment_Depth_top) (Exported: 06 March 2026)
Projection: EPSG:7856

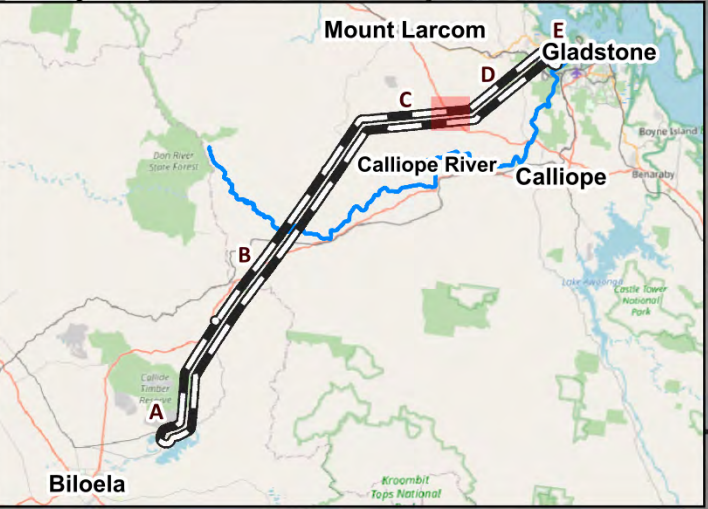

- Legend
- Project Area
 - Towers
 - 1 m LiDAR Extent
 - Disturbance Footprint
 - Indicative Access Tracks

- Flood depth (m)
- up to 0.25 m
 - 0.25 to 0.5 m
 - 0.5 to 1.0 m
 - 1.0 to 1.5 m
 - 1.5 to 2.0 m
 - 2.0 to 2.5 m
 - 2.5 to 3.0 m
 - 3.0 to 3.5 m
 - 3.5 to 4.0 m
 - 4.0 to 4.5 m
 - > 4.5 m

Modelling results are based on the best available elevation resolution: Copernicus. The available LiDAR data indicates areas where the elevation and therefore hydraulic model are inconsistent with local survey. All model results should be considered indicative and subject to broader survey validation.

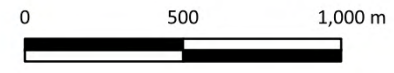

Calvale to Calliope TL Surface Water Impact Assessment

10% AEP Results
Page 14/18



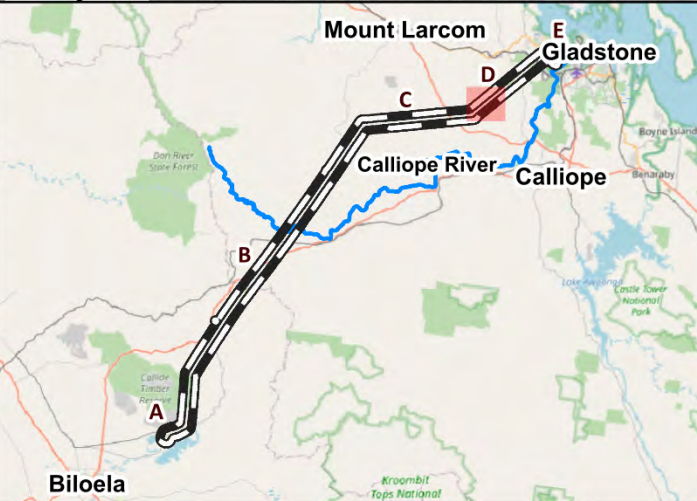
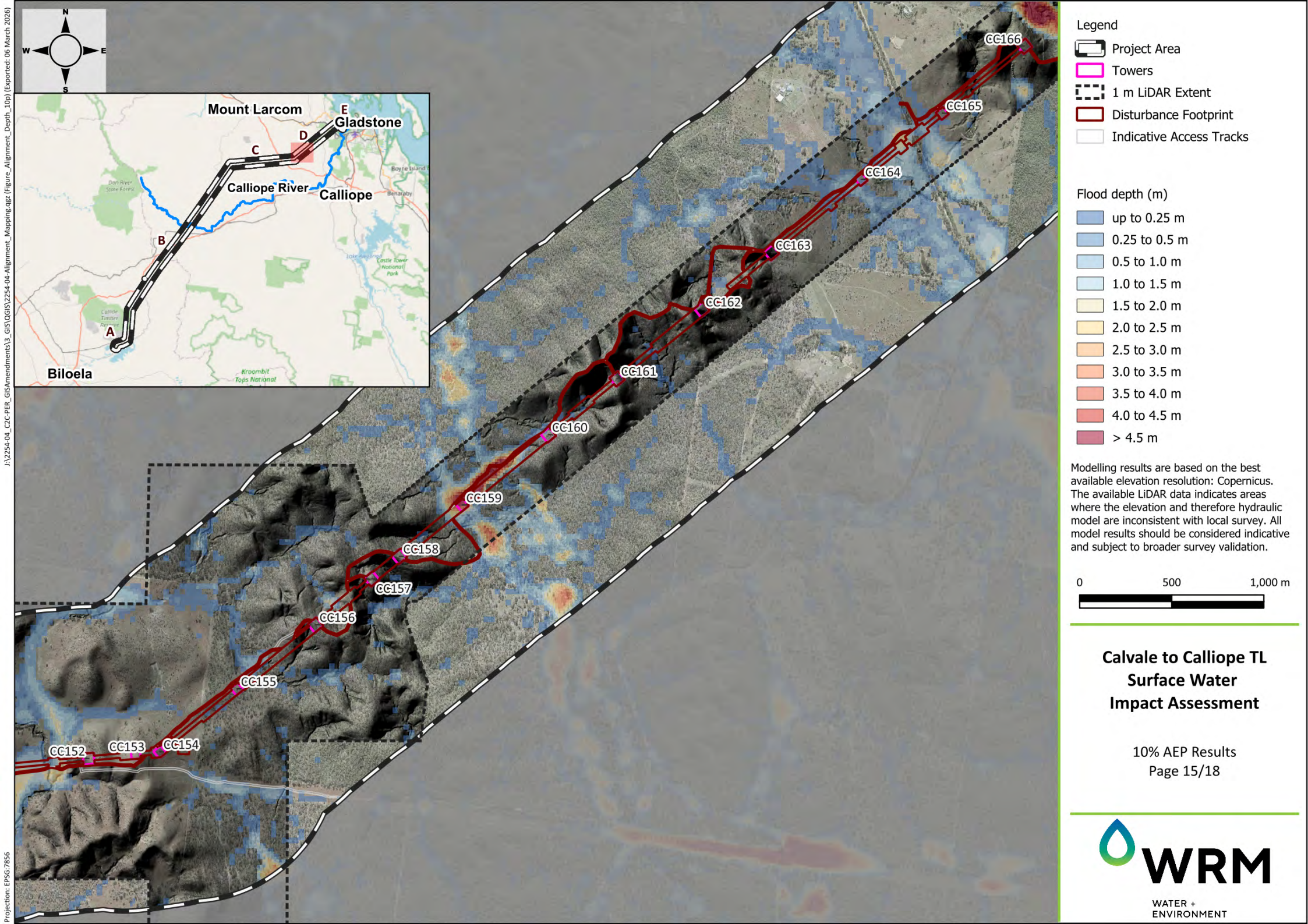

- Legend**
- Project Area
 - Towers
 - 1 m LiDAR Extent
 - Disturbance Footprint
 - Indicative Access Tracks

- Flood depth (m)**
- up to 0.25 m
 - 0.25 to 0.5 m
 - 0.5 to 1.0 m
 - 1.0 to 1.5 m
 - 1.5 to 2.0 m
 - 2.0 to 2.5 m
 - 2.5 to 3.0 m
 - 3.0 to 3.5 m
 - 3.5 to 4.0 m
 - 4.0 to 4.5 m
 - > 4.5 m

Modelling results are based on the best available elevation resolution: Copernicus. The available LiDAR data indicates areas where the elevation and therefore hydraulic model are inconsistent with local survey. All model results should be considered indicative and subject to broader survey validation.



**Calvale to Calliope TL
Surface Water
Impact Assessment**

10% AEP Results
Page 15/18



Projection: EPSG:7856

J:\2254-04_C2C-PER_GISAmendments\3_GIS\QGIS\2254-04-Alignment_Mapping.qgz (Figure_Alignment_Depth_top) (Exported: 06 March 2026)

J:\2254-04_C2C-PER_GISAmendments\3_GIS\GIS\2254-04-Alignment_Mapping_02\Figure_Alignment_Depth_10p | Exported: 06 March 2026
Projection: EPSG:7856

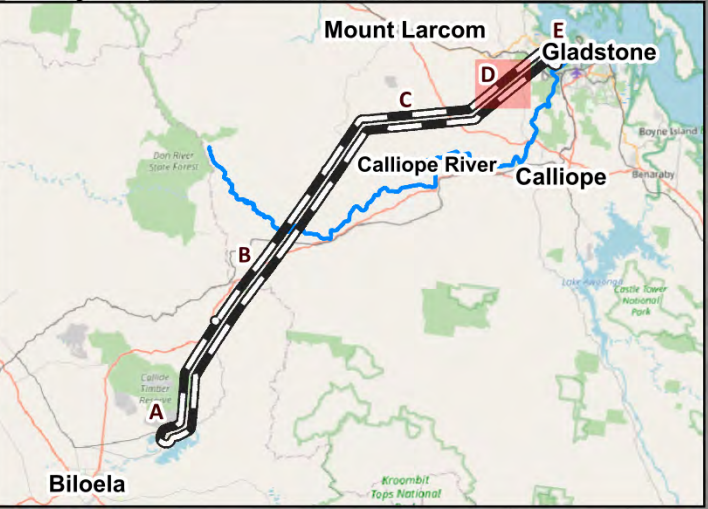

- Legend**
- Project Area
 - Towers
 - 1 m LiDAR Extent
 - Disturbance Footprint
 - Indicative Access Tracks

- Flood depth (m)**
- up to 0.25 m
 - 0.25 to 0.5 m
 - 0.5 to 1.0 m
 - 1.0 to 1.5 m
 - 1.5 to 2.0 m
 - 2.0 to 2.5 m
 - 2.5 to 3.0 m
 - 3.0 to 3.5 m
 - 3.5 to 4.0 m
 - 4.0 to 4.5 m
 - > 4.5 m

Modelling results are based on the best available elevation resolution: Copernicus. The available LiDAR data indicates areas where the elevation and therefore hydraulic model are inconsistent with local survey. All model results should be considered indicative and subject to broader survey validation.

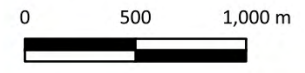

Calvale to Calliope TL Surface Water Impact Assessment

10% AEP Results
Page 16/18



J:\2254-04_C2C-PER_GISAmendments\3_GIS\GIS\2254-04-Alignment_Mapping_02\Figure_Alignment_Depth_top | Exported: 06 March 2026
Projection: EPSG:7856

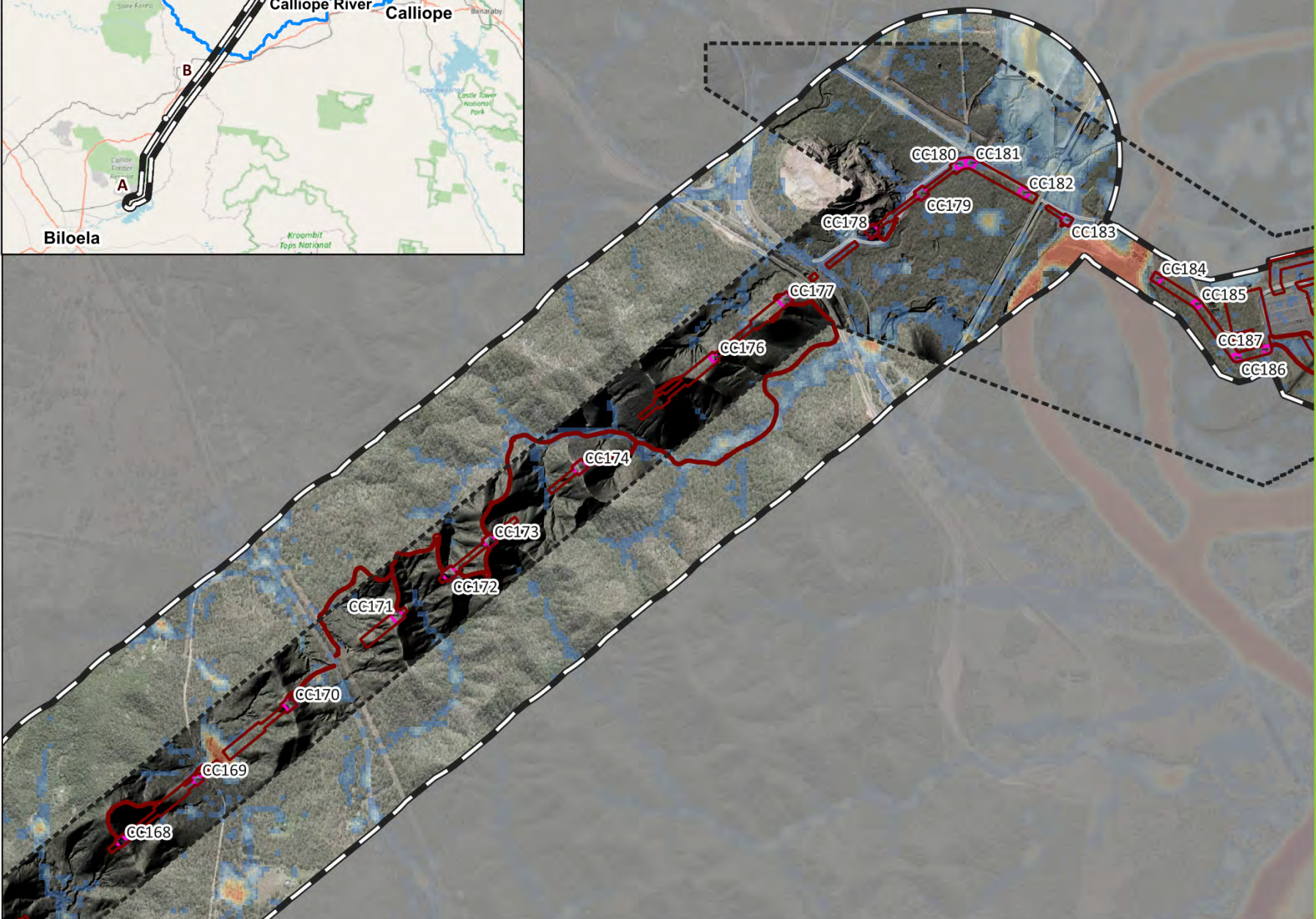

- Legend**
- Project Area
 - Towers
 - 1 m LiDAR Extent
 - Disturbance Footprint
 - Indicative Access Tracks

- Flood depth (m)**
- up to 0.25 m
 - 0.25 to 0.5 m
 - 0.5 to 1.0 m
 - 1.0 to 1.5 m
 - 1.5 to 2.0 m
 - 2.0 to 2.5 m
 - 2.5 to 3.0 m
 - 3.0 to 3.5 m
 - 3.5 to 4.0 m
 - 4.0 to 4.5 m
 - > 4.5 m

Modelling results are based on the best available elevation resolution: Copernicus. The available LiDAR data indicates areas where the elevation and therefore hydraulic model are inconsistent with local survey. All model results should be considered indicative and subject to broader survey validation.

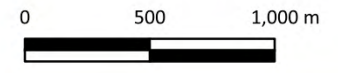

Calvale to Calliope TL Surface Water Impact Assessment

10% AEP Results
Page 17/18



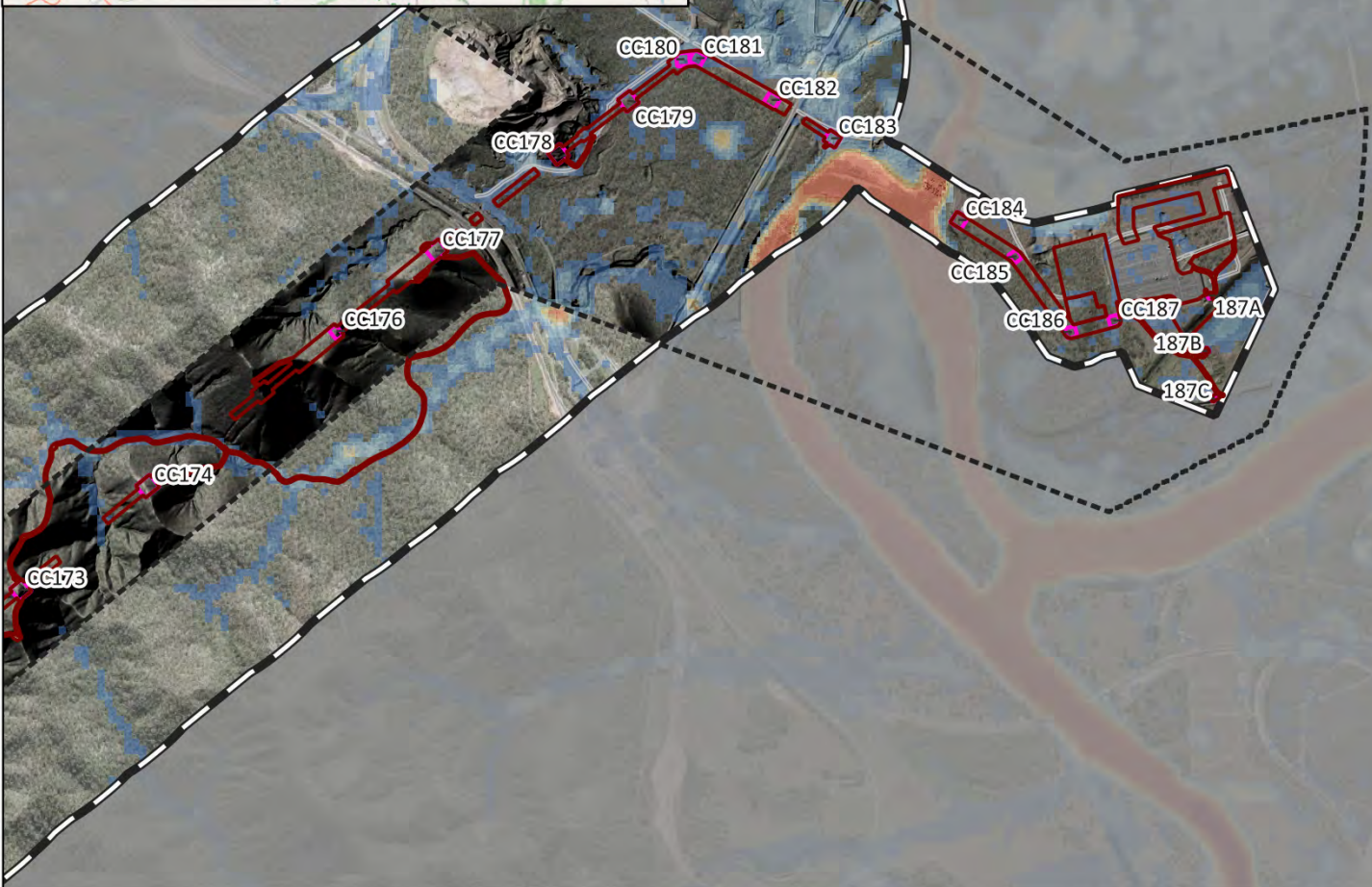

- Legend**
- Project Area
 - Towers
 - 1 m LiDAR Extent
 - Disturbance Footprint
 - Indicative Access Tracks

- Flood depth (m)**
- up to 0.25 m
 - 0.25 to 0.5 m
 - 0.5 to 1.0 m
 - 1.0 to 1.5 m
 - 1.5 to 2.0 m
 - 2.0 to 2.5 m
 - 2.5 to 3.0 m
 - 3.0 to 3.5 m
 - 3.5 to 4.0 m
 - 4.0 to 4.5 m
 - > 4.5 m

Modelling results are based on the best available elevation resolution: Copernicus. The available LiDAR data indicates areas where the elevation and therefore hydraulic model are inconsistent with local survey. All model results should be considered indicative and subject to broader survey validation.



Calvale to Calliope TL Surface Water Impact Assessment

10% AEP Results
Page 18/18



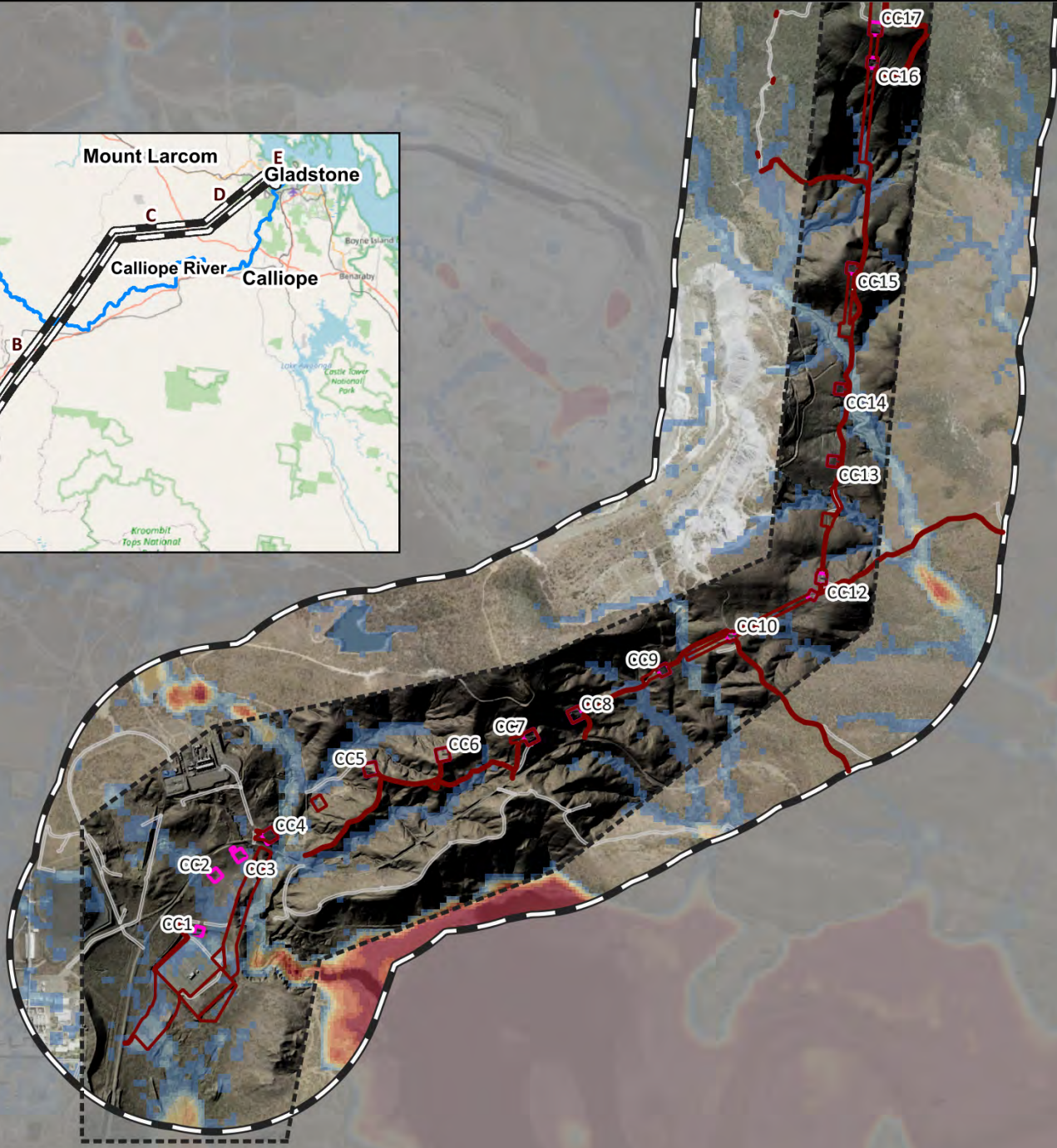
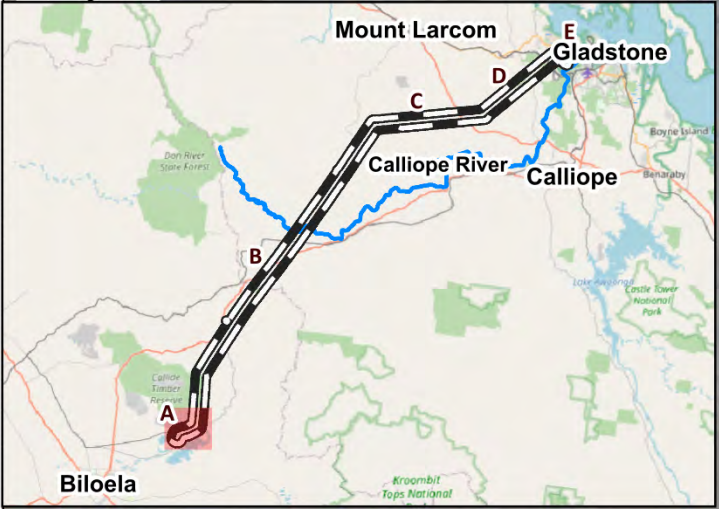

- Legend**
- Project Area
 - Towers
 - 1 m LiDAR Extent
 - Disturbance Footprint
 - Indicative Access Tracks

- Flood depth (m)**
- up to 0.25 m
 - 0.25 to 0.5 m
 - 0.5 to 1.0 m
 - 1.0 to 1.5 m
 - 1.5 to 2.0 m
 - 2.0 to 2.5 m
 - 2.5 to 3.0 m
 - 3.0 to 3.5 m
 - 3.5 to 4.0 m
 - 4.0 to 4.5 m
 - > 4.5 m

Modelling results are based on the best available elevation resolution: Copernicus. The available LiDAR data indicates areas where the elevation and therefore hydraulic model are inconsistent with local survey. All model results should be considered indicative and subject to broader survey validation.

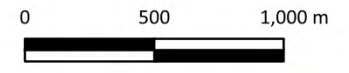

Calvale to Calliope TL Surface Water Impact Assessment

0.2% (1in500) AEP Results
Page 1/18



J:\2254-04_C2C-PER_GISA\amendments\3_GIS\OGIS\2254-04-Alignment_Mapping.gzg (Figure_Alignment_Depth_1in500) (Exported: 06 March 2026)
Projection: EPSG:7856

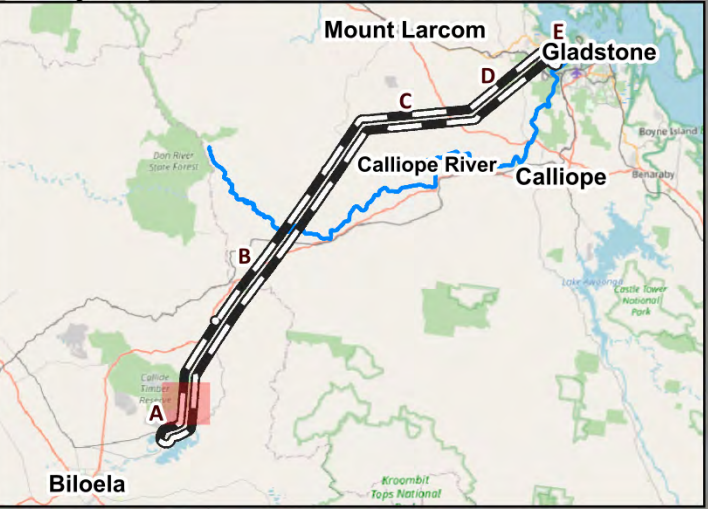

- Legend**
- Project Area
 - Towers
 - 1 m LiDAR Extent
 - Disturbance Footprint
 - Indicative Access Tracks

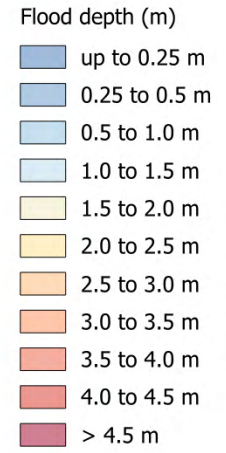

Modelling results are based on the best available elevation resolution: Copernicus. The available LiDAR data indicates areas where the elevation and therefore hydraulic model are inconsistent with local survey. All model results should be considered indicative and subject to broader survey validation.

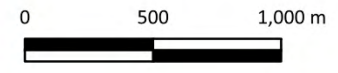

Calvale to Calliope TL Surface Water Impact Assessment

0.2% (1in500) AEP Results
Page 2/18





- Legend**
- Project Area
 - Towers
 - 1 m LiDAR Extent
 - Disturbance Footprint
 - Indicative Access Tracks

- Flood depth (m)**
- up to 0.25 m
 - 0.25 to 0.5 m
 - 0.5 to 1.0 m
 - 1.0 to 1.5 m
 - 1.5 to 2.0 m
 - 2.0 to 2.5 m
 - 2.5 to 3.0 m
 - 3.0 to 3.5 m
 - 3.5 to 4.0 m
 - 4.0 to 4.5 m
 - > 4.5 m

Modelling results are based on the best available elevation resolution: Copernicus. The available LiDAR data indicates areas where the elevation and therefore hydraulic model are inconsistent with local survey. All model results should be considered indicative and subject to broader survey validation.

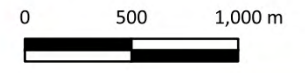

**Calvale to Calliope TL
Surface Water
Impact Assessment**

0.2% (1in500) AEP Results
Page 3/18



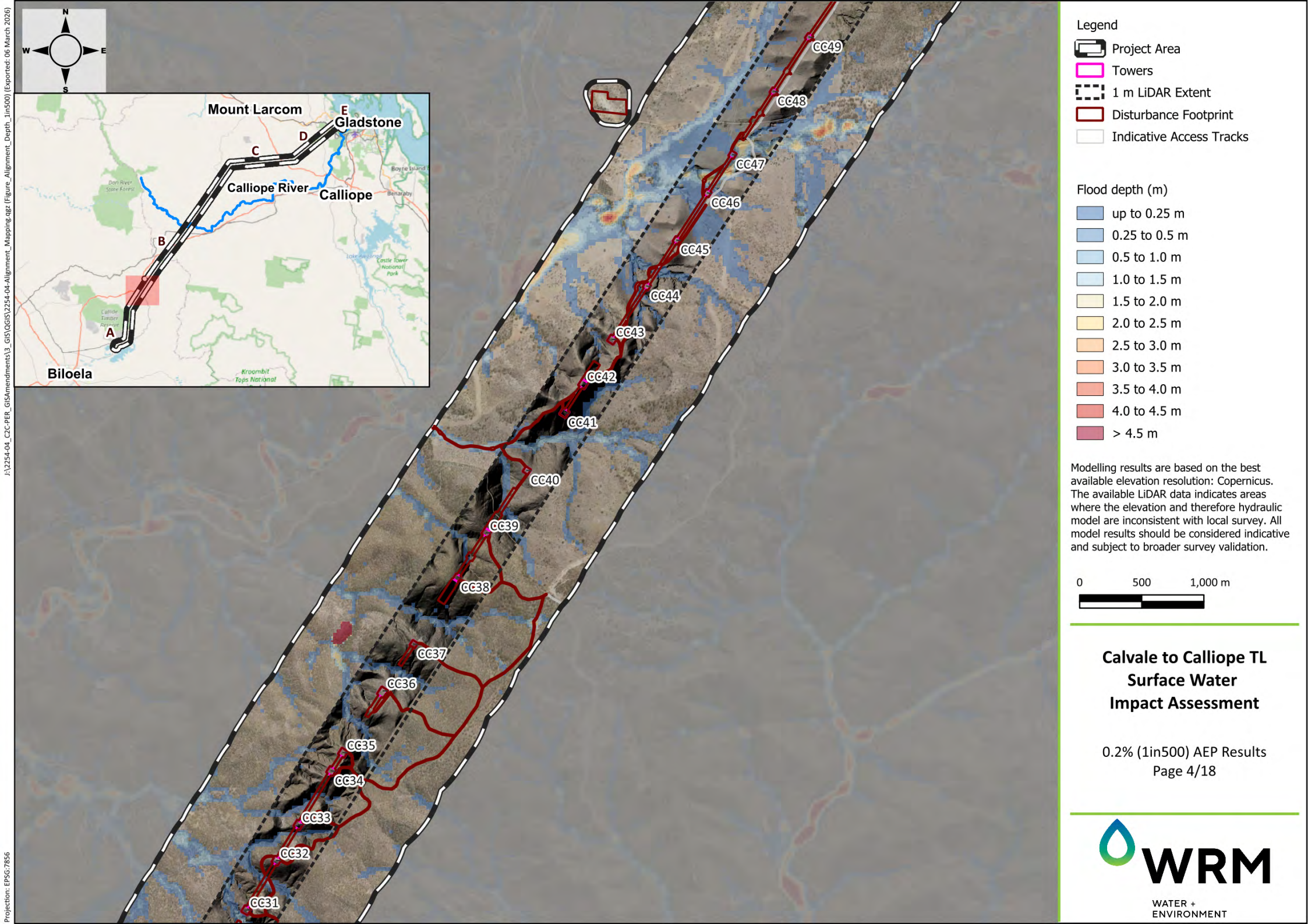

- Legend**
- Project Area
 - Towers
 - 1 m LiDAR Extent
 - Disturbance Footprint
 - Indicative Access Tracks

- Flood depth (m)**
- up to 0.25 m
 - 0.25 to 0.5 m
 - 0.5 to 1.0 m
 - 1.0 to 1.5 m
 - 1.5 to 2.0 m
 - 2.0 to 2.5 m
 - 2.5 to 3.0 m
 - 3.0 to 3.5 m
 - 3.5 to 4.0 m
 - 4.0 to 4.5 m
 - > 4.5 m

Modelling results are based on the best available elevation resolution: Copernicus. The available LiDAR data indicates areas where the elevation and therefore hydraulic model are inconsistent with local survey. All model results should be considered indicative and subject to broader survey validation.

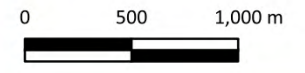

**Calvale to Calliope TL
Surface Water
Impact Assessment**

0.2% (1in500) AEP Results
Page 4/18



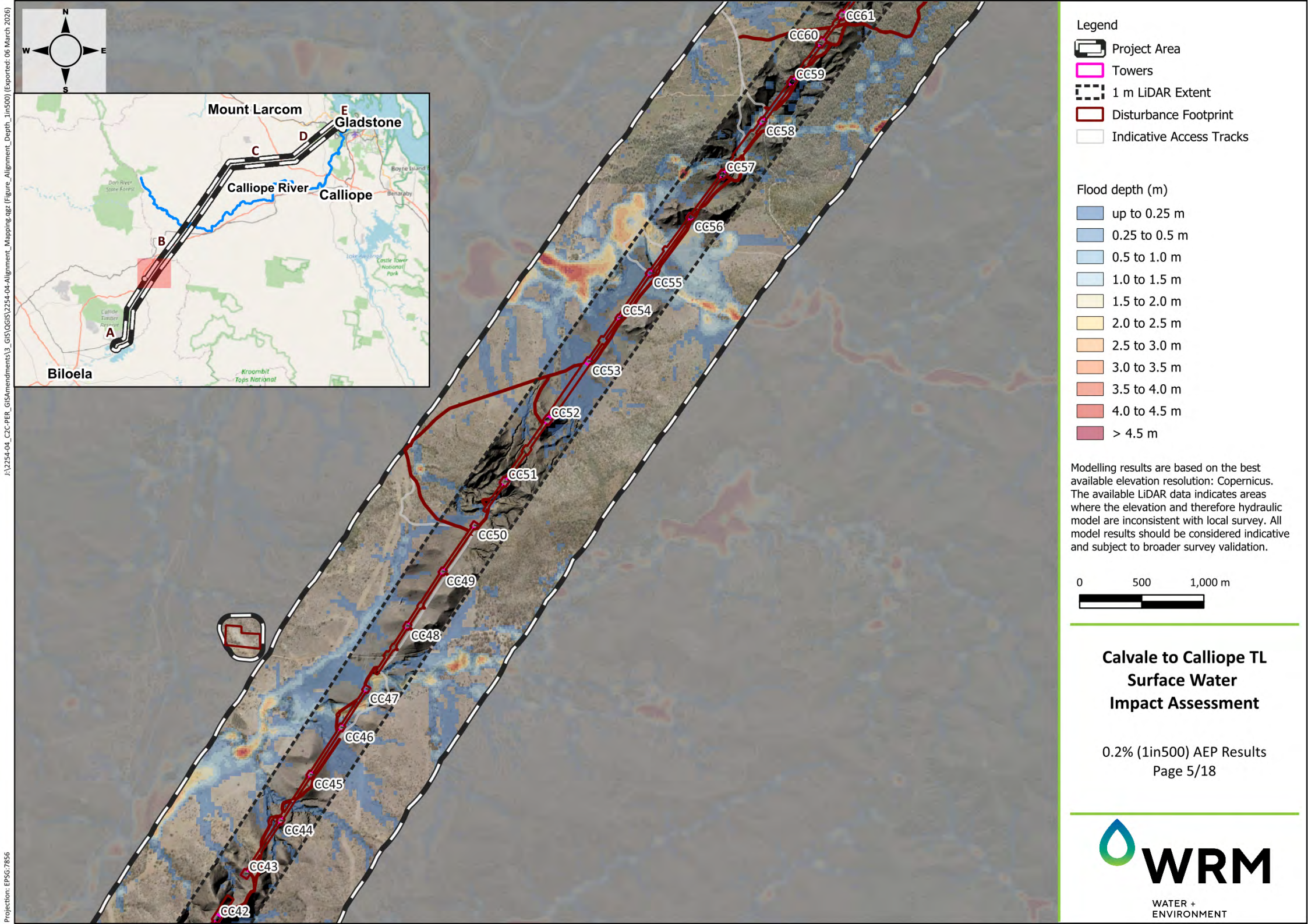

I:\2254-04_C2C-PER_GISA\Amendments\3_GIS\GIS\2254-04-Alignment_Mapping.gxz (Figure_Alignment_Depth_1in500) (Exported: 06 March 2026)

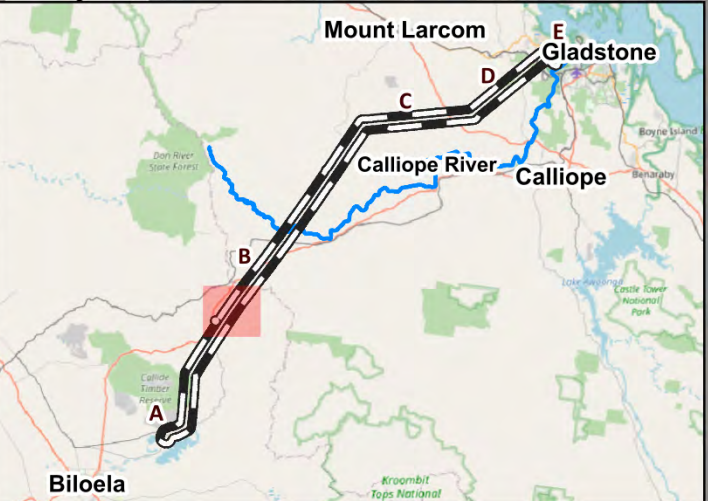

- Legend**
- Project Area
 - Towers
 - 1 m LiDAR Extent
 - Disturbance Footprint
 - Indicative Access Tracks

- Flood depth (m)**
- up to 0.25 m
 - 0.25 to 0.5 m
 - 0.5 to 1.0 m
 - 1.0 to 1.5 m
 - 1.5 to 2.0 m
 - 2.0 to 2.5 m
 - 2.5 to 3.0 m
 - 3.0 to 3.5 m
 - 3.5 to 4.0 m
 - 4.0 to 4.5 m
 - > 4.5 m

Modelling results are based on the best available elevation resolution: Copernicus. The available LiDAR data indicates areas where the elevation and therefore hydraulic model are inconsistent with local survey. All model results should be considered indicative and subject to broader survey validation.

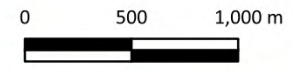

**Calvale to Calliope TL
Surface Water
Impact Assessment**

0.2% (1in500) AEP Results
Page 5/18



Projection: EPSG:7856

J:\2254-04_C2C-PER_GISA\Amendments\3_GIS\OGIS\2254-04-Alignment_Mapping.gzg (Figure_Alignment_Depth_1in500) (Exported: 06 March 2026)
Projection: EPSG:7856



- Legend**
- Project Area
 - Towers
 - 1 m LiDAR Extent
 - Disturbance Footprint
 - Indicative Access Tracks

- Flood depth (m)**
- up to 0.25 m
 - 0.25 to 0.5 m
 - 0.5 to 1.0 m
 - 1.0 to 1.5 m
 - 1.5 to 2.0 m
 - 2.0 to 2.5 m
 - 2.5 to 3.0 m
 - 3.0 to 3.5 m
 - 3.5 to 4.0 m
 - 4.0 to 4.5 m
 - > 4.5 m

Modelling results are based on the best available elevation resolution: Copernicus. The available LiDAR data indicates areas where the elevation and therefore hydraulic model are inconsistent with local survey. All model results should be considered indicative and subject to broader survey validation.

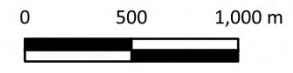

Calvale to Calliope TL Surface Water Impact Assessment

0.2% (1in500) AEP Results
Page 6/18



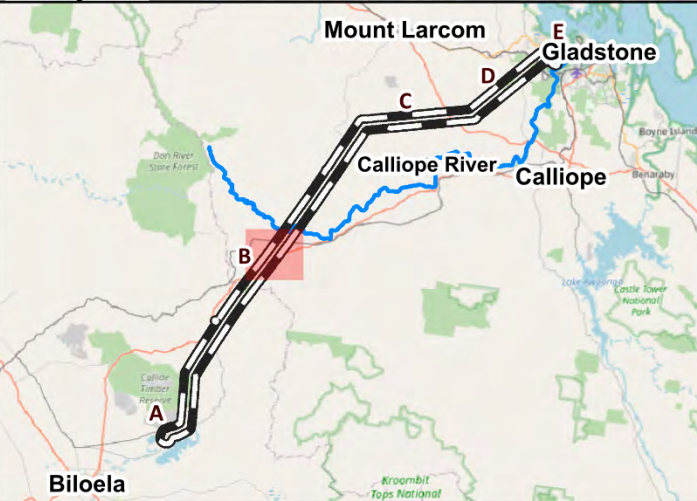
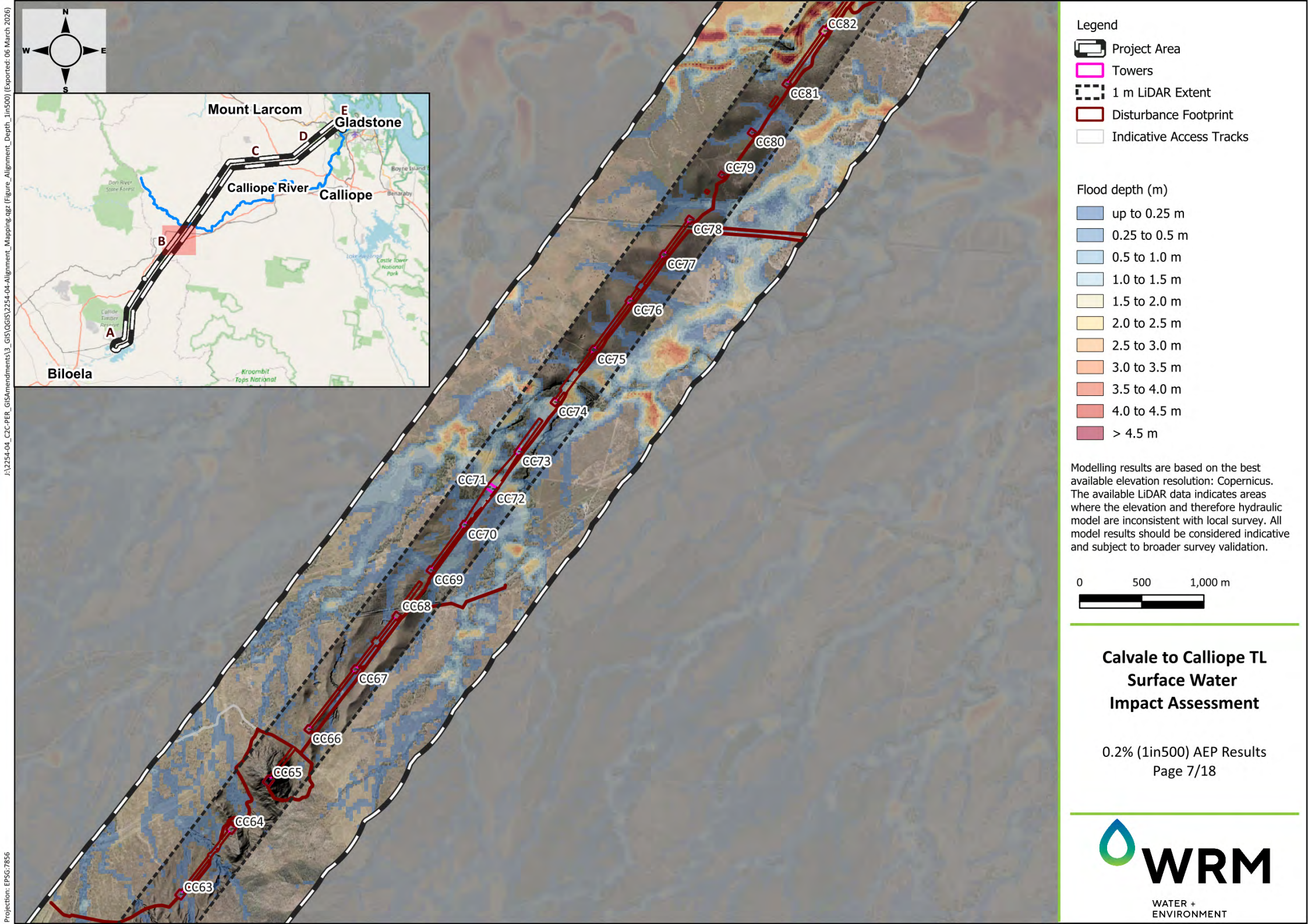

- Legend**
- Project Area
 - Towers
 - 1 m LiDAR Extent
 - Disturbance Footprint
 - Indicative Access Tracks

- Flood depth (m)**
- up to 0.25 m
 - 0.25 to 0.5 m
 - 0.5 to 1.0 m
 - 1.0 to 1.5 m
 - 1.5 to 2.0 m
 - 2.0 to 2.5 m
 - 2.5 to 3.0 m
 - 3.0 to 3.5 m
 - 3.5 to 4.0 m
 - 4.0 to 4.5 m
 - > 4.5 m

Modelling results are based on the best available elevation resolution: Copernicus. The available LiDAR data indicates areas where the elevation and therefore hydraulic model are inconsistent with local survey. All model results should be considered indicative and subject to broader survey validation.

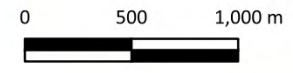

**Calvale to Calliope TL
Surface Water
Impact Assessment**

0.2% (1in500) AEP Results
Page 7/18



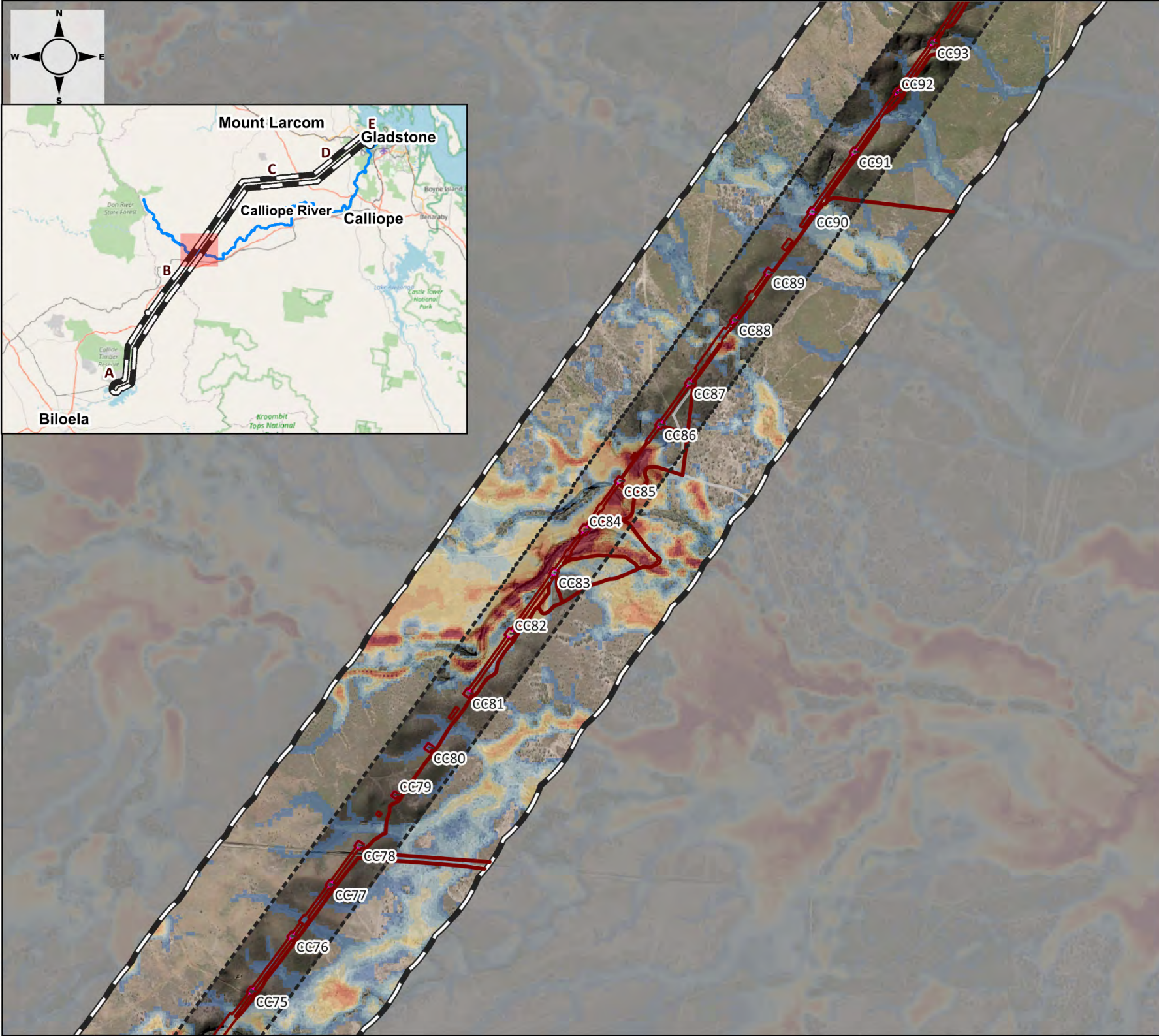
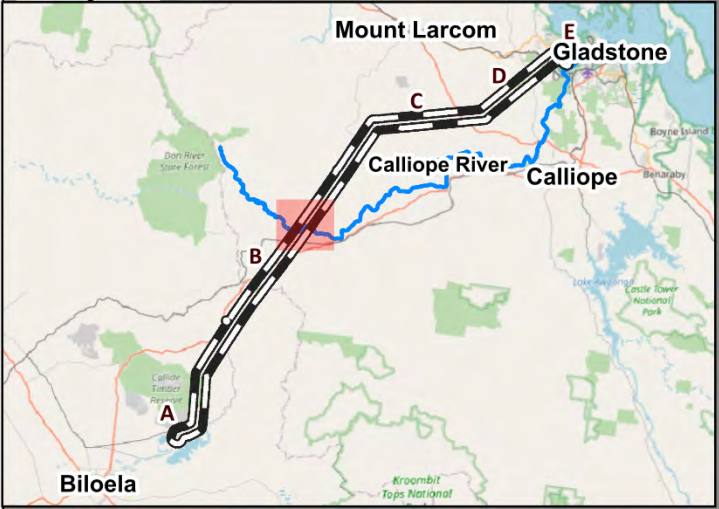

- Legend**
- Project Area
 - Towers
 - 1 m LiDAR Extent
 - Disturbance Footprint
 - Indicative Access Tracks

- Flood depth (m)**
- up to 0.25 m
 - 0.25 to 0.5 m
 - 0.5 to 1.0 m
 - 1.0 to 1.5 m
 - 1.5 to 2.0 m
 - 2.0 to 2.5 m
 - 2.5 to 3.0 m
 - 3.0 to 3.5 m
 - 3.5 to 4.0 m
 - 4.0 to 4.5 m
 - > 4.5 m

Modelling results are based on the best available elevation resolution: Copernicus. The available LiDAR data indicates areas where the elevation and therefore hydraulic model are inconsistent with local survey. All model results should be considered indicative and subject to broader survey validation.



**Calvale to Calliope TL
Surface Water
Impact Assessment**

0.2% (1in500) AEP Results
Page 8/18



J:\2254-04_C2C-PER_GISA\Amendments\3_GIS\GIS\2254-04-Alignment_Mapping.gzg (Figure_Alignment_Depth_1in500) (Exported: 06 March 2026)
Projection: EPSG:7856



- Legend**
- Project Area
 - Towers
 - 1 m LiDAR Extent
 - Disturbance Footprint
 - Indicative Access Tracks

- Flood depth (m)**
- up to 0.25 m
 - 0.25 to 0.5 m
 - 0.5 to 1.0 m
 - 1.0 to 1.5 m
 - 1.5 to 2.0 m
 - 2.0 to 2.5 m
 - 2.5 to 3.0 m
 - 3.0 to 3.5 m
 - 3.5 to 4.0 m
 - 4.0 to 4.5 m
 - > 4.5 m

Modelling results are based on the best available elevation resolution: Copernicus. The available LiDAR data indicates areas where the elevation and therefore hydraulic model are inconsistent with local survey. All model results should be considered indicative and subject to broader survey validation.

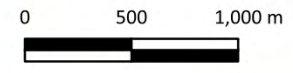

Calvale to Calliope TL Surface Water Impact Assessment

0.2% (1in500) AEP Results
Page 9/18



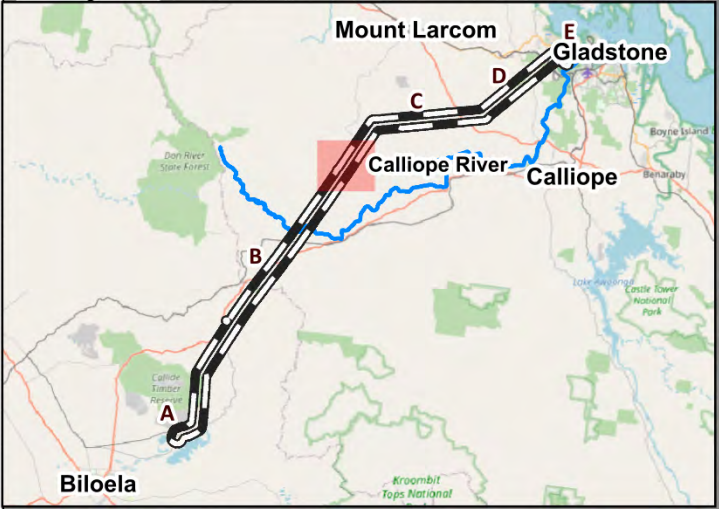

- Legend**
- Project Area
 - Towers
 - 1 m LiDAR Extent
 - Disturbance Footprint
 - Indicative Access Tracks

- Flood depth (m)**
- up to 0.25 m
 - 0.25 to 0.5 m
 - 0.5 to 1.0 m
 - 1.0 to 1.5 m
 - 1.5 to 2.0 m
 - 2.0 to 2.5 m
 - 2.5 to 3.0 m
 - 3.0 to 3.5 m
 - 3.5 to 4.0 m
 - 4.0 to 4.5 m
 - > 4.5 m

Modelling results are based on the best available elevation resolution: Copernicus. The available LiDAR data indicates areas where the elevation and therefore hydraulic model are inconsistent with local survey. All model results should be considered indicative and subject to broader survey validation.



**Calvale to Calliope TL
Surface Water
Impact Assessment**

0.2% (1in500) AEP Results
Page 10/18



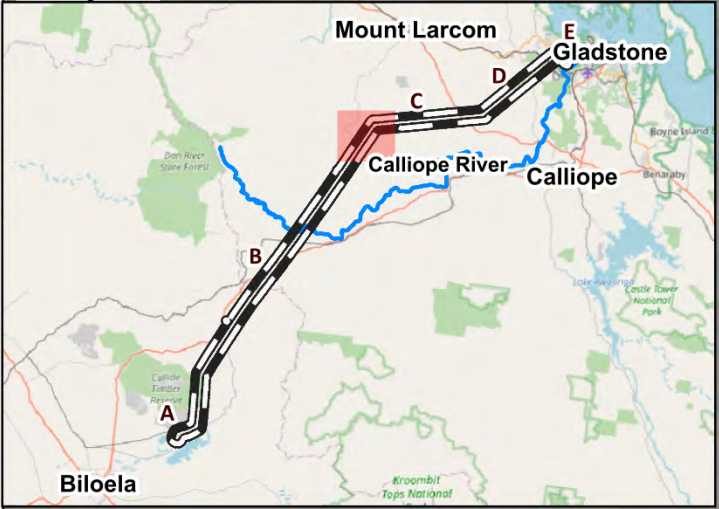

- Legend**
- Project Area
 - Towers
 - 1 m LiDAR Extent
 - Disturbance Footprint
 - Indicative Access Tracks

- Flood depth (m)**
- up to 0.25 m
 - 0.25 to 0.5 m
 - 0.5 to 1.0 m
 - 1.0 to 1.5 m
 - 1.5 to 2.0 m
 - 2.0 to 2.5 m
 - 2.5 to 3.0 m
 - 3.0 to 3.5 m
 - 3.5 to 4.0 m
 - 4.0 to 4.5 m
 - > 4.5 m

Modelling results are based on the best available elevation resolution: Copernicus. The available LiDAR data indicates areas where the elevation and therefore hydraulic model are inconsistent with local survey. All model results should be considered indicative and subject to broader survey validation.



Calvale to Calliope TL Surface Water Impact Assessment

0.2% (1in500) AEP Results
Page 11/18



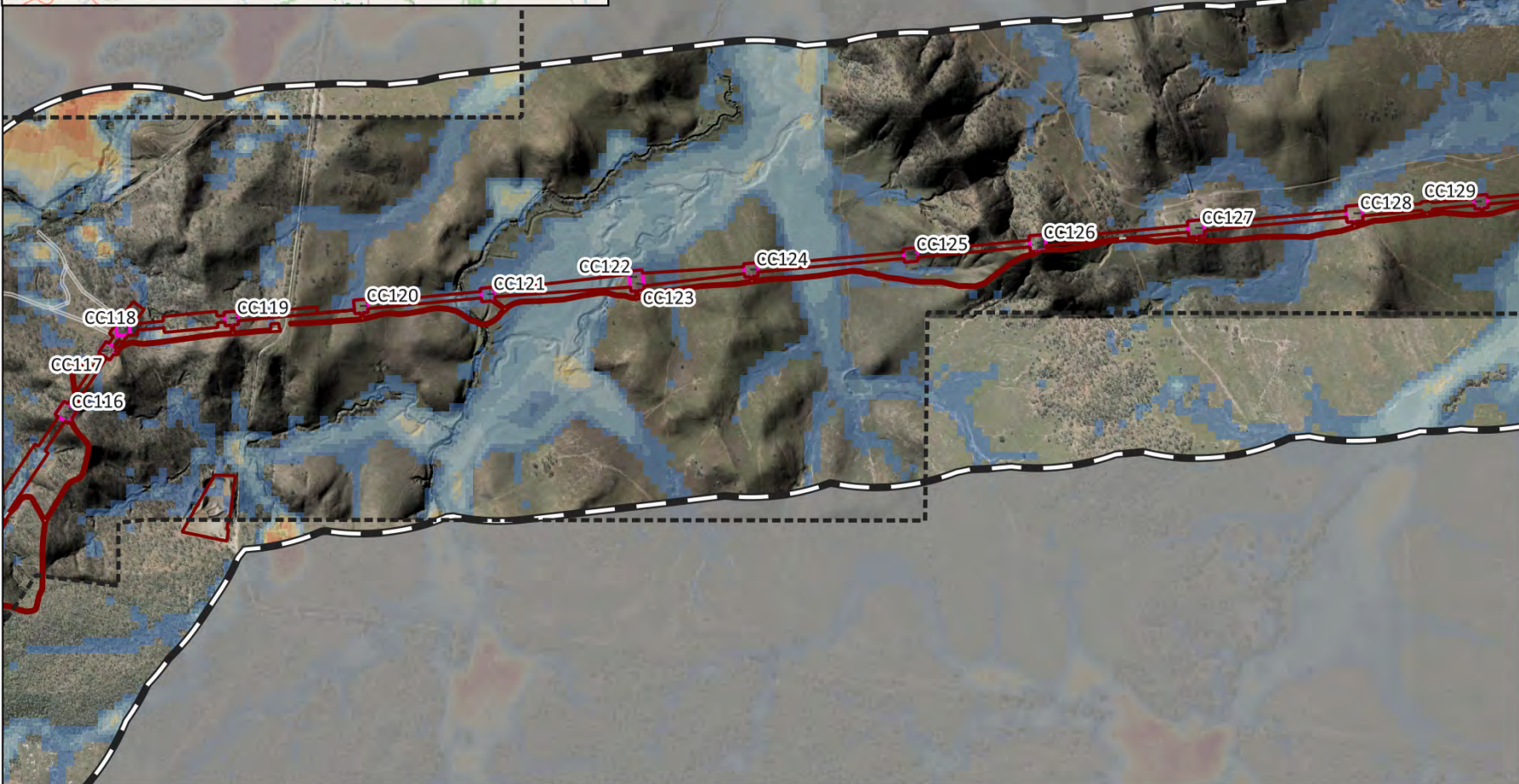
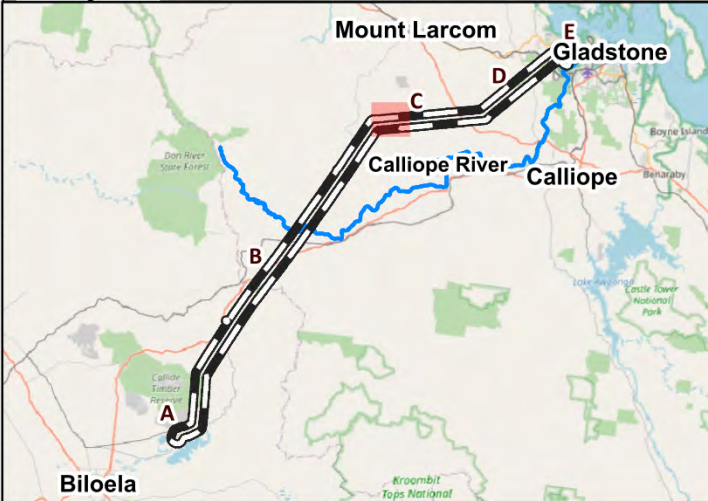

- Legend**
- Project Area
 - Towers
 - 1 m LiDAR Extent
 - Disturbance Footprint
 - Indicative Access Tracks

- Flood depth (m)**
- up to 0.25 m
 - 0.25 to 0.5 m
 - 0.5 to 1.0 m
 - 1.0 to 1.5 m
 - 1.5 to 2.0 m
 - 2.0 to 2.5 m
 - 2.5 to 3.0 m
 - 3.0 to 3.5 m
 - 3.5 to 4.0 m
 - 4.0 to 4.5 m
 - > 4.5 m

Modelling results are based on the best available elevation resolution: Copernicus. The available LiDAR data indicates areas where the elevation and therefore hydraulic model are inconsistent with local survey. All model results should be considered indicative and subject to broader survey validation.



**Calvale to Calliope TL
Surface Water
Impact Assessment**

0.2% (1in500) AEP Results
Page 12/18



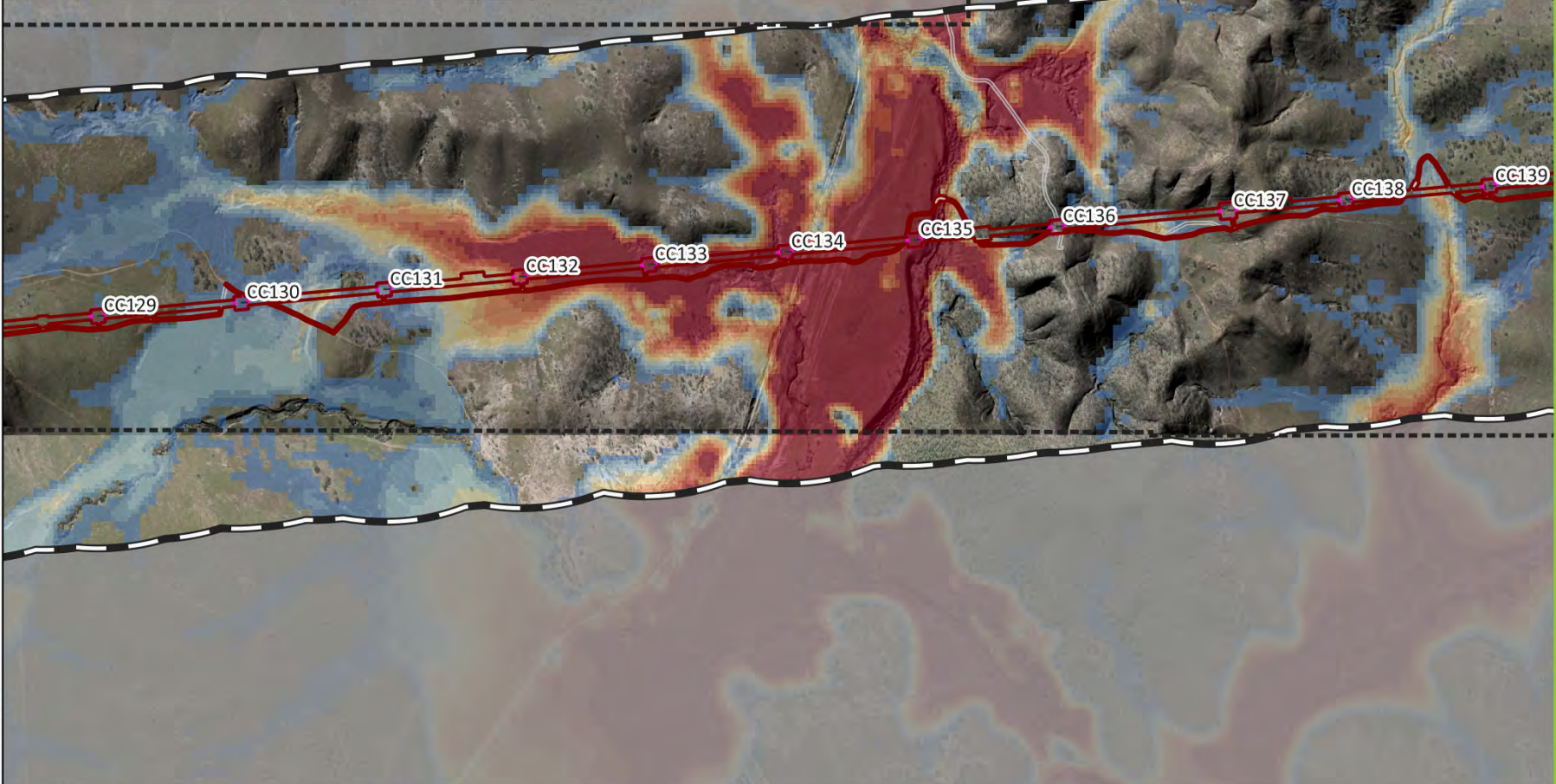
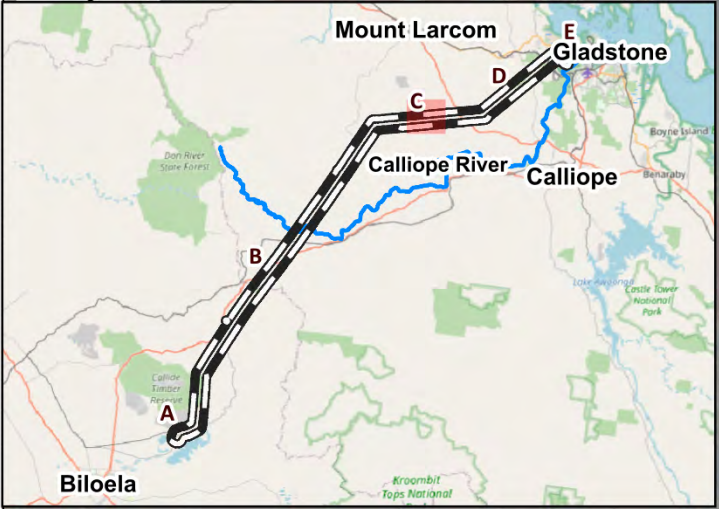

- Legend**
- Project Area
 - Towers
 - 1 m LiDAR Extent
 - Disturbance Footprint
 - Indicative Access Tracks

- Flood depth (m)**
- up to 0.25 m
 - 0.25 to 0.5 m
 - 0.5 to 1.0 m
 - 1.0 to 1.5 m
 - 1.5 to 2.0 m
 - 2.0 to 2.5 m
 - 2.5 to 3.0 m
 - 3.0 to 3.5 m
 - 3.5 to 4.0 m
 - 4.0 to 4.5 m
 - > 4.5 m

Modelling results are based on the best available elevation resolution: Copernicus. The available LiDAR data indicates areas where the elevation and therefore hydraulic model are inconsistent with local survey. All model results should be considered indicative and subject to broader survey validation.



**Calvale to Calliope TL
Surface Water
Impact Assessment**

0.2% (1in500) AEP Results
Page 13/18



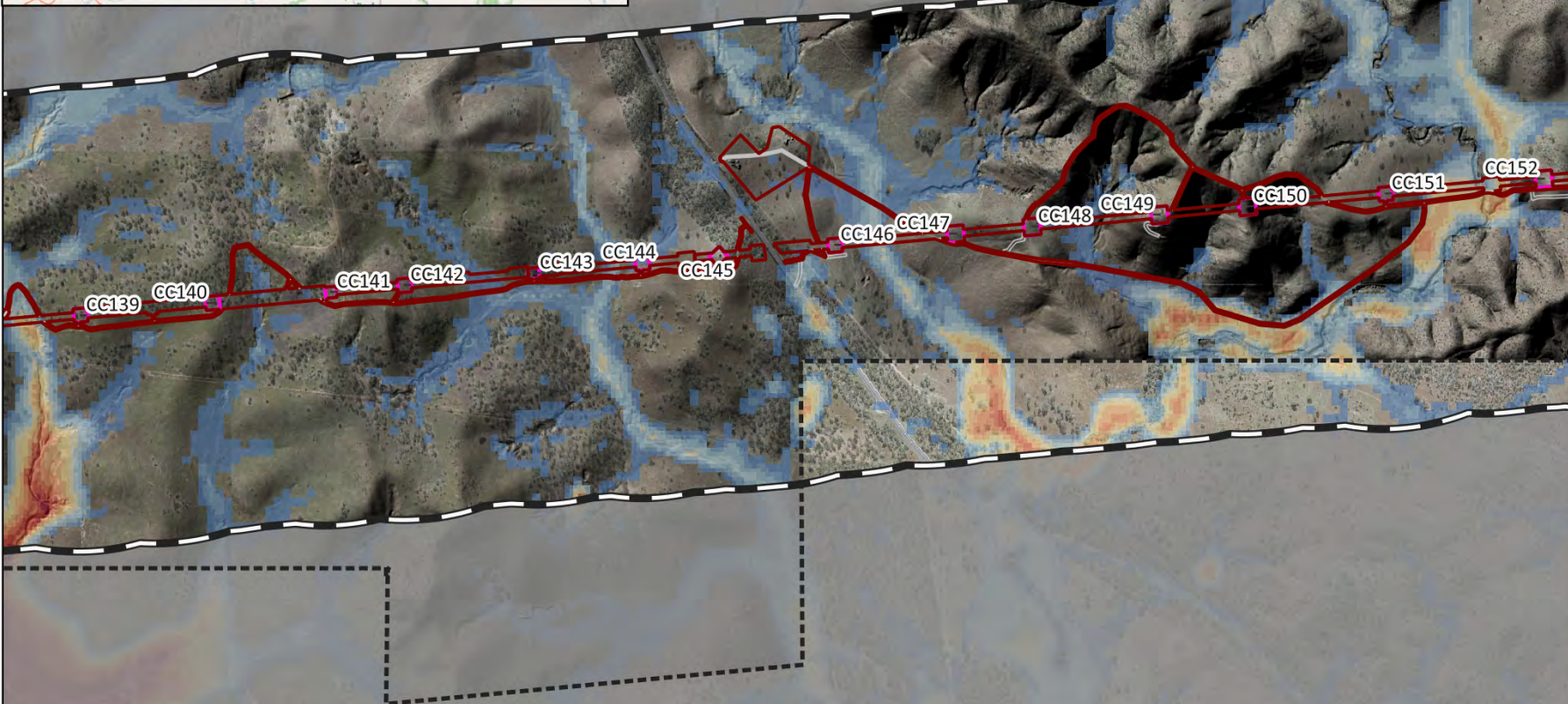
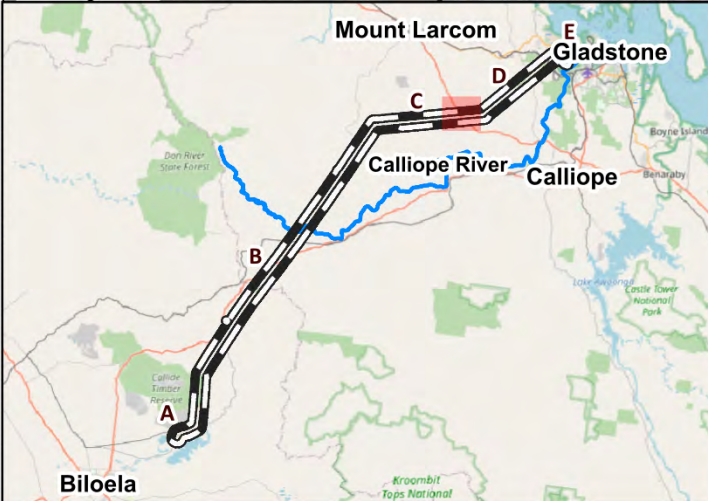

Legend

- Project Area
- Towers
- 1 m LiDAR Extent
- Disturbance Footprint
- Indicative Access Tracks

Flood depth (m)

- up to 0.25 m
- 0.25 to 0.5 m
- 0.5 to 1.0 m
- 1.0 to 1.5 m
- 1.5 to 2.0 m
- 2.0 to 2.5 m
- 2.5 to 3.0 m
- 3.0 to 3.5 m
- 3.5 to 4.0 m
- 4.0 to 4.5 m
- > 4.5 m

Modelling results are based on the best available elevation resolution: Copernicus. The available LiDAR data indicates areas where the elevation and therefore hydraulic model are inconsistent with local survey. All model results should be considered indicative and subject to broader survey validation.

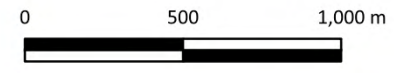

Calvale to Calliope TL Surface Water Impact Assessment

0.2% (1in500) AEP Results
Page 14/18



WATER + ENVIRONMENT

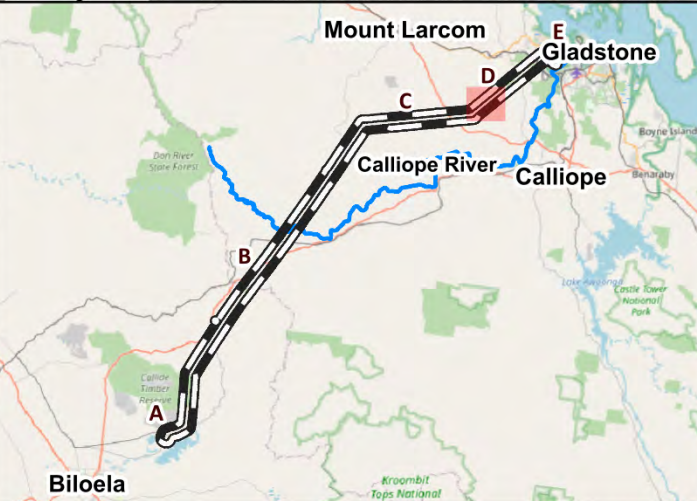
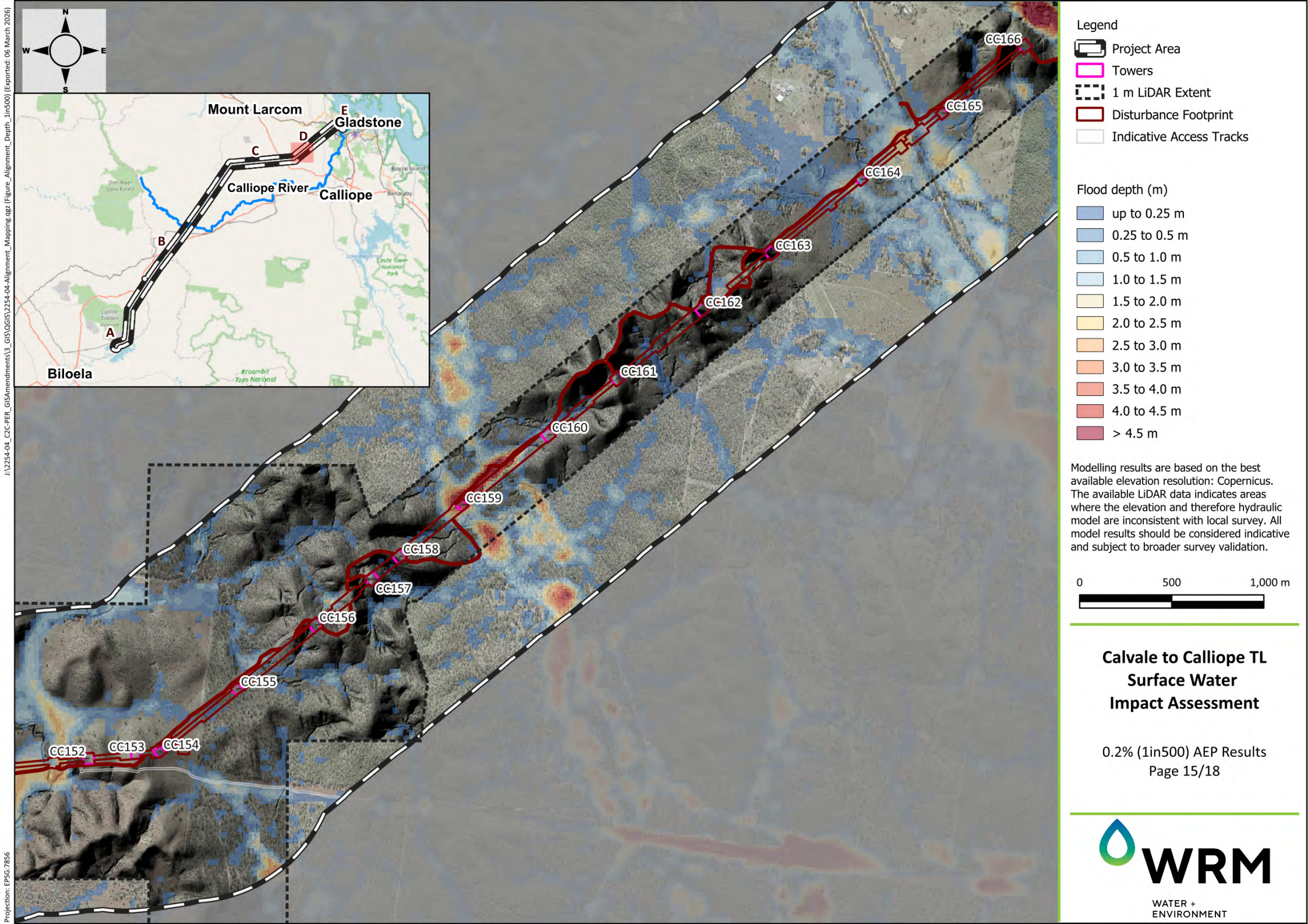

- Legend**
- Project Area
 - Towers
 - 1 m LiDAR Extent
 - Disturbance Footprint
 - Indicative Access Tracks

- Flood depth (m)**
- up to 0.25 m
 - 0.25 to 0.5 m
 - 0.5 to 1.0 m
 - 1.0 to 1.5 m
 - 1.5 to 2.0 m
 - 2.0 to 2.5 m
 - 2.5 to 3.0 m
 - 3.0 to 3.5 m
 - 3.5 to 4.0 m
 - 4.0 to 4.5 m
 - > 4.5 m

Modelling results are based on the best available elevation resolution: Copernicus. The available LiDAR data indicates areas where the elevation and therefore hydraulic model are inconsistent with local survey. All model results should be considered indicative and subject to broader survey validation.



**Calvale to Calliope TL
Surface Water
Impact Assessment**

0.2% (1in500) AEP Results
Page 15/18



Projection: EPSG:7856

I:\2254-04_C2C-PER_GISA\Amendments\3_GIS\OGIS\2254-04-Alignment_Mapping.gxz (Figure_Alignment_Depth_1in500) (Exported: 06 March 2026)

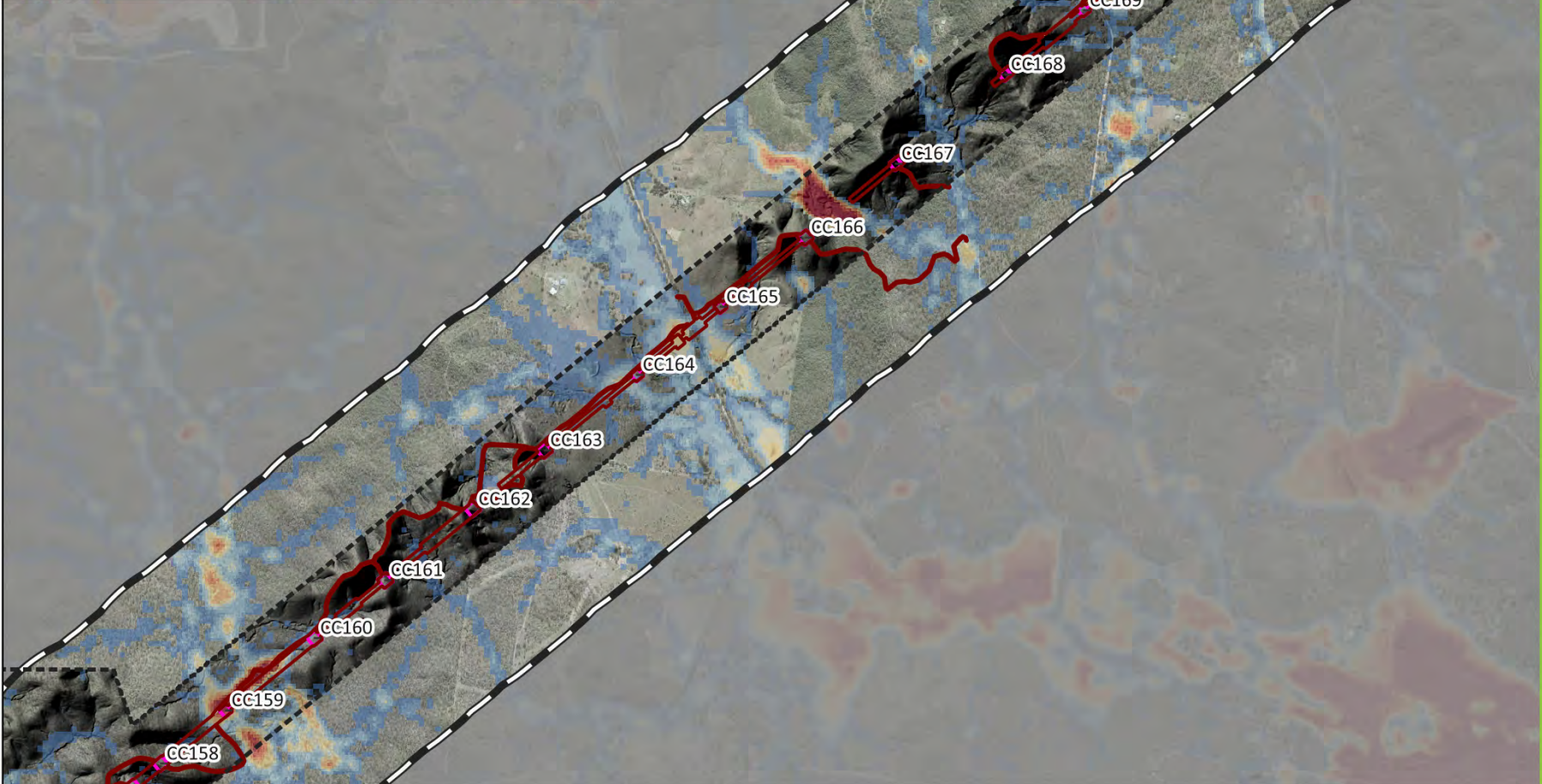
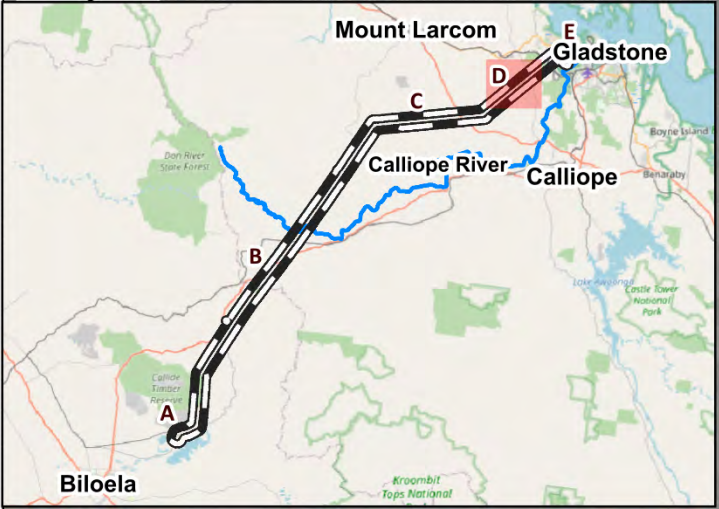

- Legend**
- Project Area
 - Towers
 - 1 m LiDAR Extent
 - Disturbance Footprint
 - Indicative Access Tracks

- Flood depth (m)**
- up to 0.25 m
 - 0.25 to 0.5 m
 - 0.5 to 1.0 m
 - 1.0 to 1.5 m
 - 1.5 to 2.0 m
 - 2.0 to 2.5 m
 - 2.5 to 3.0 m
 - 3.0 to 3.5 m
 - 3.5 to 4.0 m
 - 4.0 to 4.5 m
 - > 4.5 m

Modelling results are based on the best available elevation resolution: Copernicus. The available LiDAR data indicates areas where the elevation and therefore hydraulic model are inconsistent with local survey. All model results should be considered indicative and subject to broader survey validation.

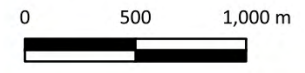

**Calvale to Calliope TL
Surface Water
Impact Assessment**

0.2% (1in500) AEP Results
Page 16/18



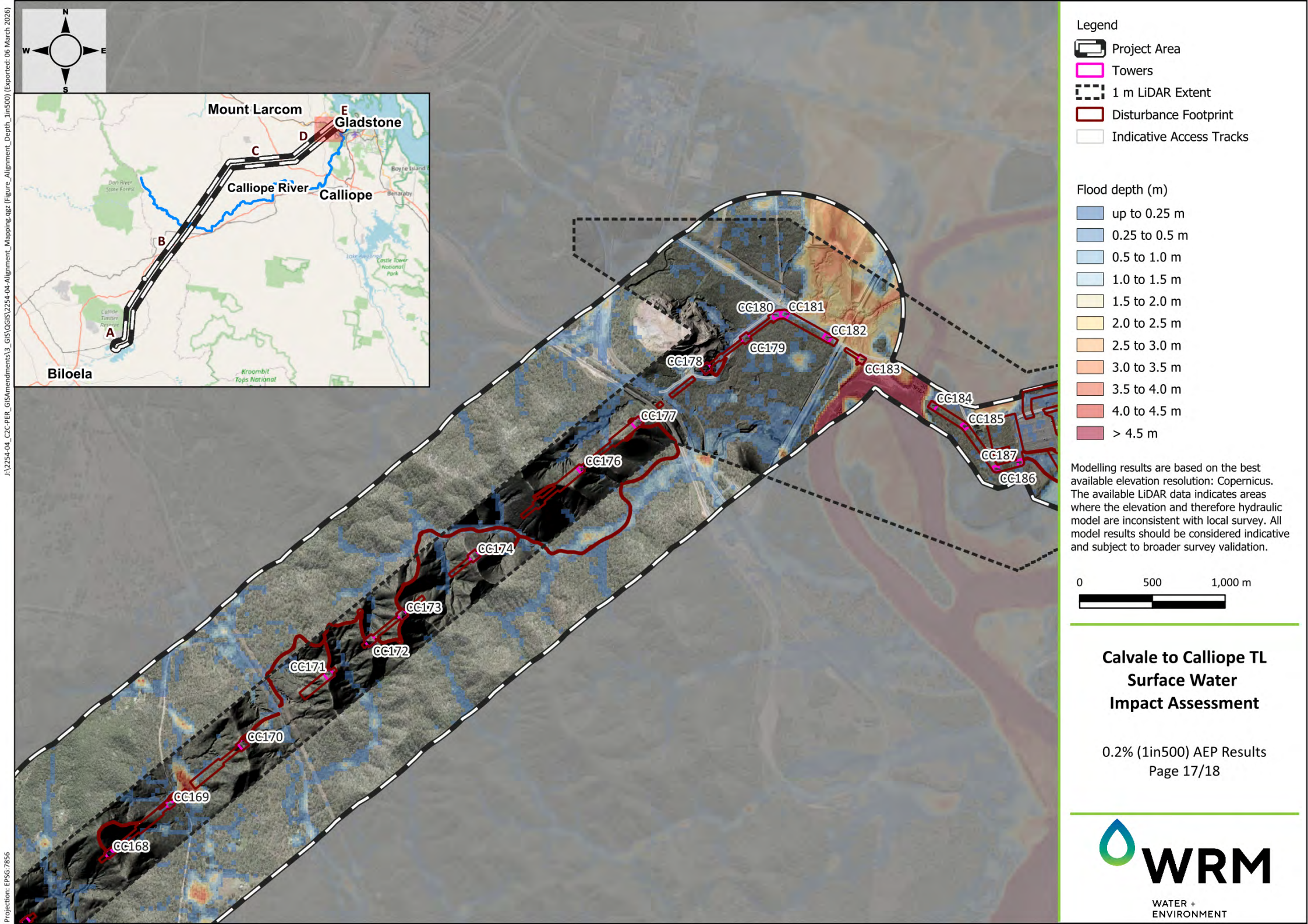

- Legend**
- Project Area
 - Towers
 - 1 m LiDAR Extent
 - Disturbance Footprint
 - Indicative Access Tracks

- Flood depth (m)**
- up to 0.25 m
 - 0.25 to 0.5 m
 - 0.5 to 1.0 m
 - 1.0 to 1.5 m
 - 1.5 to 2.0 m
 - 2.0 to 2.5 m
 - 2.5 to 3.0 m
 - 3.0 to 3.5 m
 - 3.5 to 4.0 m
 - 4.0 to 4.5 m
 - > 4.5 m

Modelling results are based on the best available elevation resolution: Copernicus. The available LiDAR data indicates areas where the elevation and therefore hydraulic model are inconsistent with local survey. All model results should be considered indicative and subject to broader survey validation.

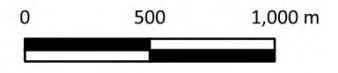

**Calvale to Calliope TL
Surface Water
Impact Assessment**

0.2% (1in500) AEP Results
Page 17/18



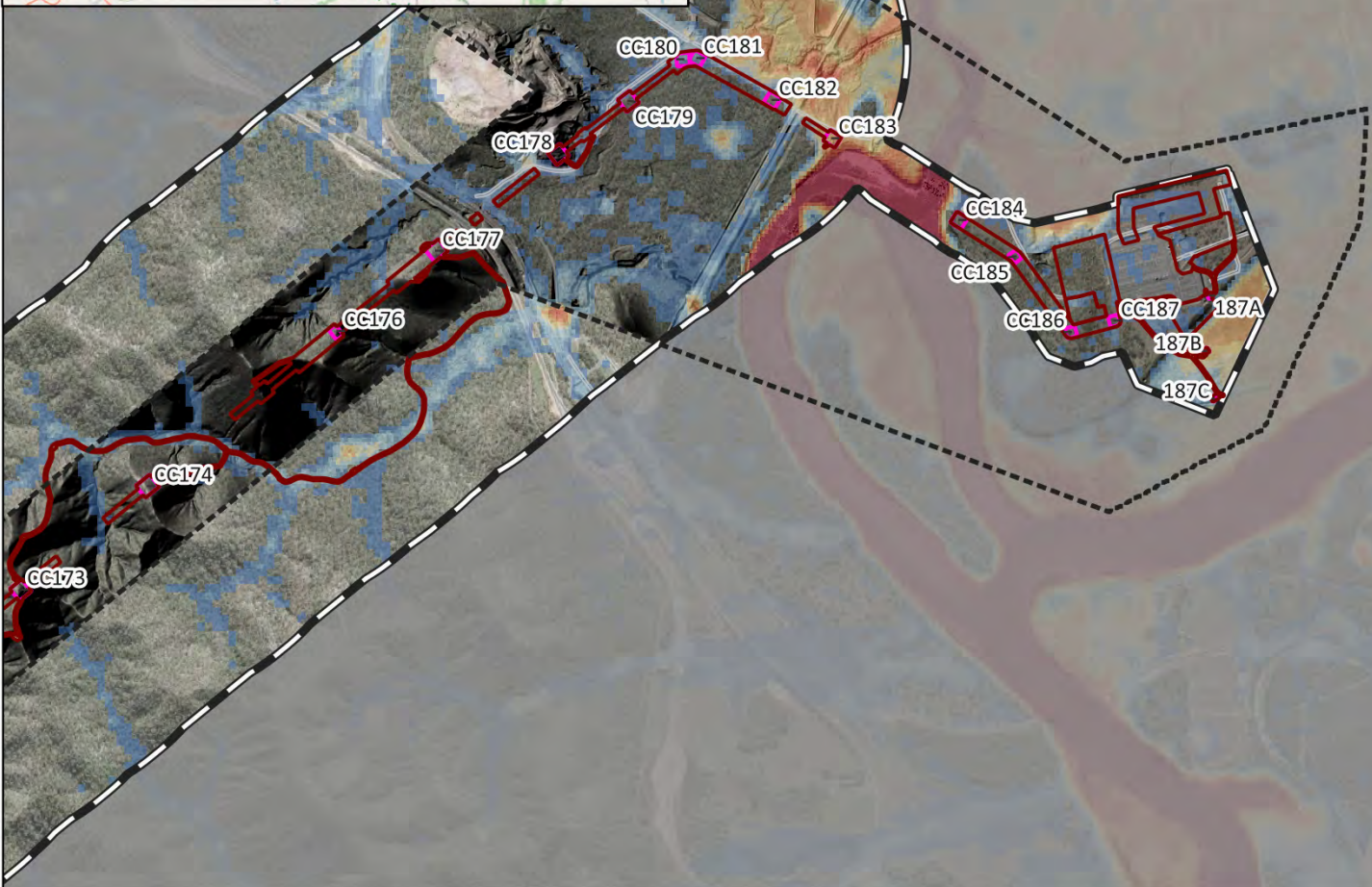

- Legend**
- Project Area
 - Towers
 - 1 m LiDAR Extent
 - Disturbance Footprint
 - Indicative Access Tracks

- Flood depth (m)**
- up to 0.25 m
 - 0.25 to 0.5 m
 - 0.5 to 1.0 m
 - 1.0 to 1.5 m
 - 1.5 to 2.0 m
 - 2.0 to 2.5 m
 - 2.5 to 3.0 m
 - 3.0 to 3.5 m
 - 3.5 to 4.0 m
 - 4.0 to 4.5 m
 - > 4.5 m

Modelling results are based on the best available elevation resolution: Copernicus. The available LiDAR data indicates areas where the elevation and therefore hydraulic model are inconsistent with local survey. All model results should be considered indicative and subject to broader survey validation.



**Calvale to Calliope TL
Surface Water
Impact Assessment**

0.2% (1in500) AEP Results
Page 18/18



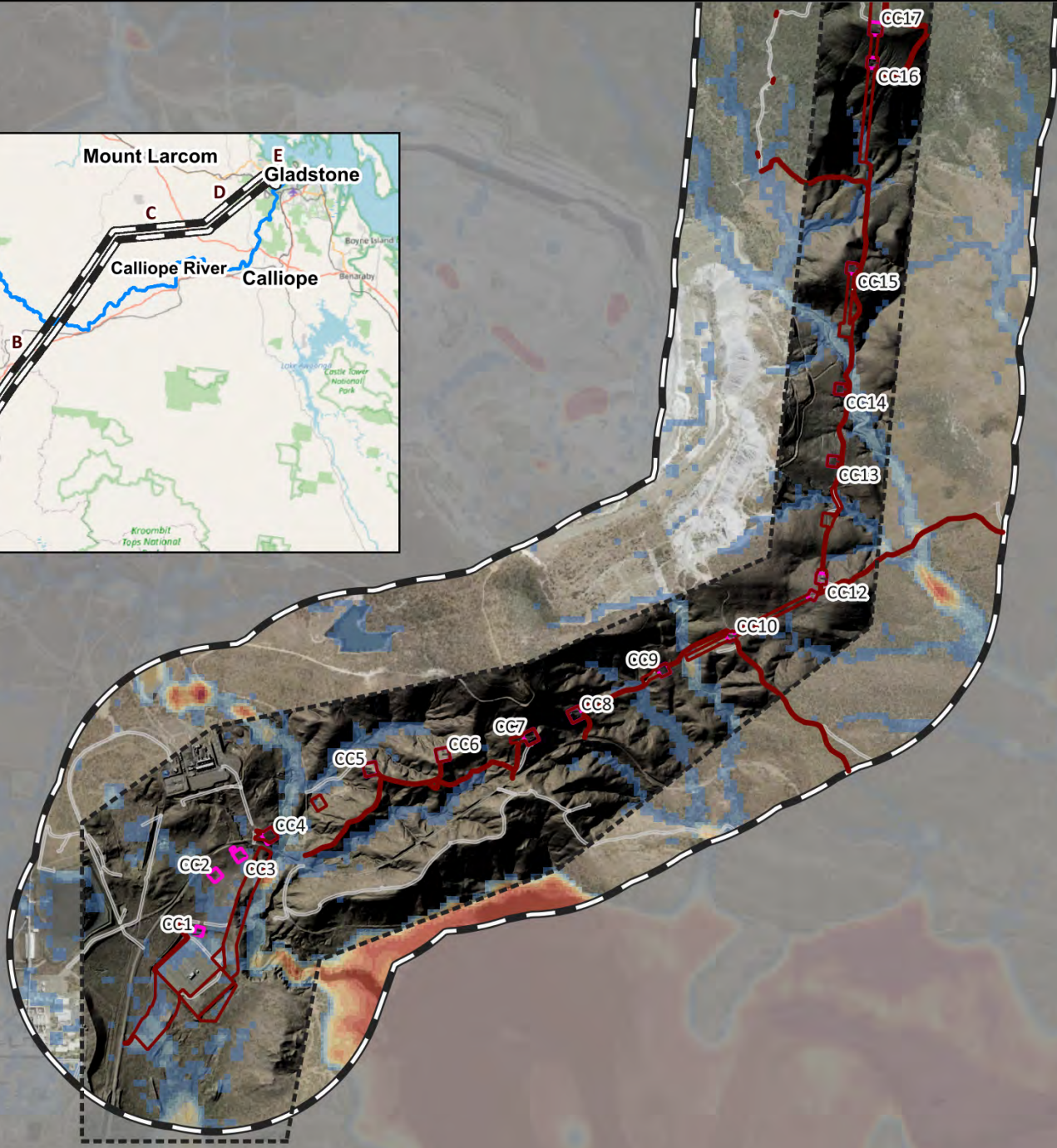

- Legend**
- Project Area
 - Towers
 - 1 m LiDAR Extent
 - Disturbance Footprint
 - Indicative Access Tracks

- Flood depth (m)**
- up to 0.25 m
 - 0.25 to 0.5 m
 - 0.5 to 1.0 m
 - 1.0 to 1.5 m
 - 1.5 to 2.0 m
 - 2.0 to 2.5 m
 - 2.5 to 3.0 m
 - 3.0 to 3.5 m
 - 3.5 to 4.0 m
 - 4.0 to 4.5 m
 - > 4.5 m

Modelling results are based on the best available elevation resolution: Copernicus. The available LiDAR data indicates areas where the elevation and therefore hydraulic model are inconsistent with local survey. All model results should be considered indicative and subject to broader survey validation.

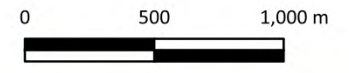

Calvale to Calliope TL Surface Water Impact Assessment

1% AEP Results
Page 1/18



Projection: EPSG:7856
I:\2254-04_C2C-PER_GIS\Amendments\3_GIS\OGIS\2254-04-Alignment_Mapping_agg_Figure_Alignment_Depth_1p | Exported: 06 March 2026

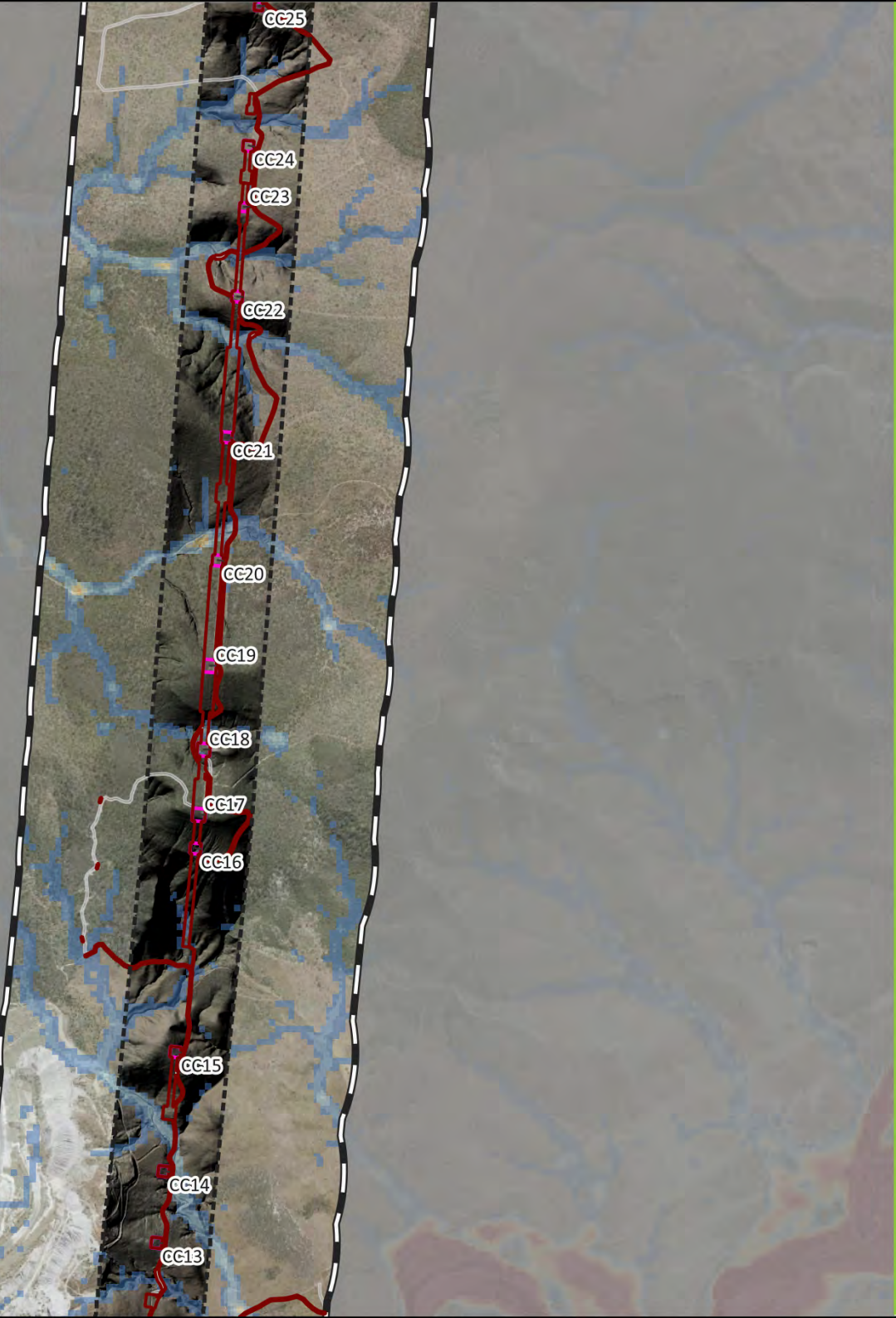
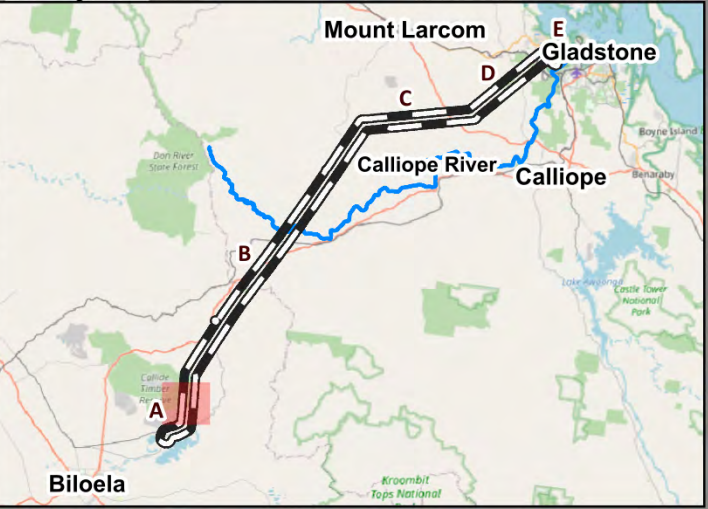

- Legend**
- Project Area
 - Towers
 - 1 m LiDAR Extent
 - Disturbance Footprint
 - Indicative Access Tracks

- Flood depth (m)**
- up to 0.25 m
 - 0.25 to 0.5 m
 - 0.5 to 1.0 m
 - 1.0 to 1.5 m
 - 1.5 to 2.0 m
 - 2.0 to 2.5 m
 - 2.5 to 3.0 m
 - 3.0 to 3.5 m
 - 3.5 to 4.0 m
 - 4.0 to 4.5 m
 - > 4.5 m

Modelling results are based on the best available elevation resolution: Copernicus. The available LiDAR data indicates areas where the elevation and therefore hydraulic model are inconsistent with local survey. All model results should be considered indicative and subject to broader survey validation.

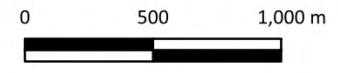

Calvale to Calliope TL Surface Water Impact Assessment

1% AEP Results
Page 2/18



Projection: EPSG:7856
I:\254-04_C2C-PER_GIS\Amendments\3_GIS\OGIS\254-04-Alignment_Mapping_agg_Figure_Depth_1p | Exported: 06 March 2026



- Legend**
- Project Area
 - Towers
 - 1 m LiDAR Extent
 - Disturbance Footprint
 - Indicative Access Tracks

- Flood depth (m)**
- up to 0.25 m
 - 0.25 to 0.5 m
 - 0.5 to 1.0 m
 - 1.0 to 1.5 m
 - 1.5 to 2.0 m
 - 2.0 to 2.5 m
 - 2.5 to 3.0 m
 - 3.0 to 3.5 m
 - 3.5 to 4.0 m
 - 4.0 to 4.5 m
 - > 4.5 m

Modelling results are based on the best available elevation resolution: Copernicus. The available LiDAR data indicates areas where the elevation and therefore hydraulic model are inconsistent with local survey. All model results should be considered indicative and subject to broader survey validation.

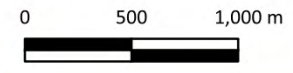

Calvale to Calliope TL Surface Water Impact Assessment

1% AEP Results
Page 3/18



Projection: EPSG:7856
I:\2254-04_C2C-PER_GISAmendments\3_GIS\QGIS\2254-04-Alignment_Depth_1p | Exported: 06 March 2026



- Legend**
- Project Area
 - Towers
 - 1 m LiDAR Extent
 - Disturbance Footprint
 - Indicative Access Tracks

- Flood depth (m)**
- up to 0.25 m
 - 0.25 to 0.5 m
 - 0.5 to 1.0 m
 - 1.0 to 1.5 m
 - 1.5 to 2.0 m
 - 2.0 to 2.5 m
 - 2.5 to 3.0 m
 - 3.0 to 3.5 m
 - 3.5 to 4.0 m
 - 4.0 to 4.5 m
 - > 4.5 m

Modelling results are based on the best available elevation resolution: Copernicus. The available LiDAR data indicates areas where the elevation and therefore hydraulic model are inconsistent with local survey. All model results should be considered indicative and subject to broader survey validation.

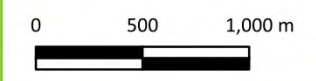

Calvale to Calliope TL Surface Water Impact Assessment

1% AEP Results
Page 4/18



Projection: EPSG:7856
I:\2254-04_C2C-PER_GIS\Amendments\3_GIS\OGIS\2254-04-Alignment_Mapping_age\Figure_Depth_1p | Exported: 06 March 2026

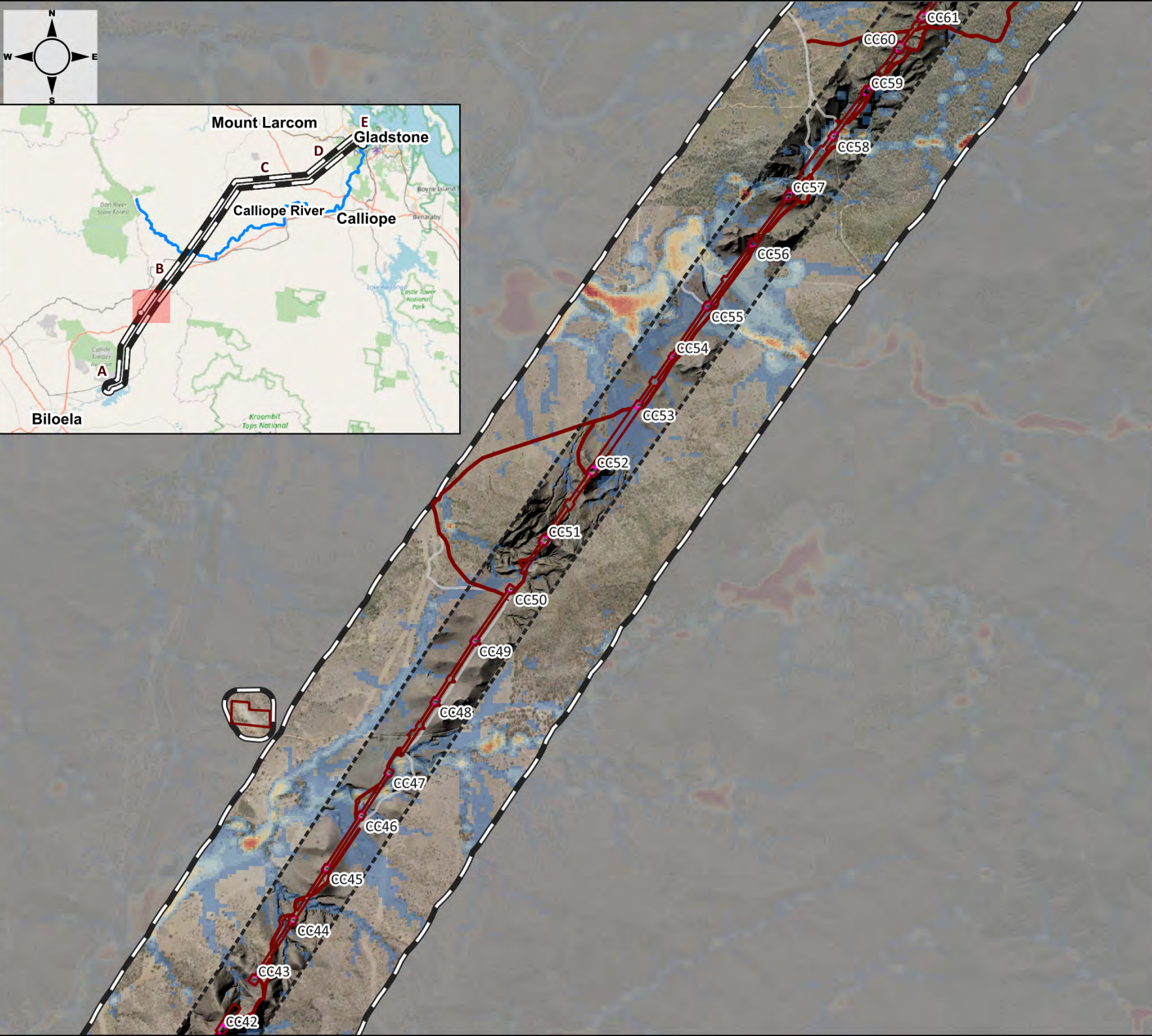
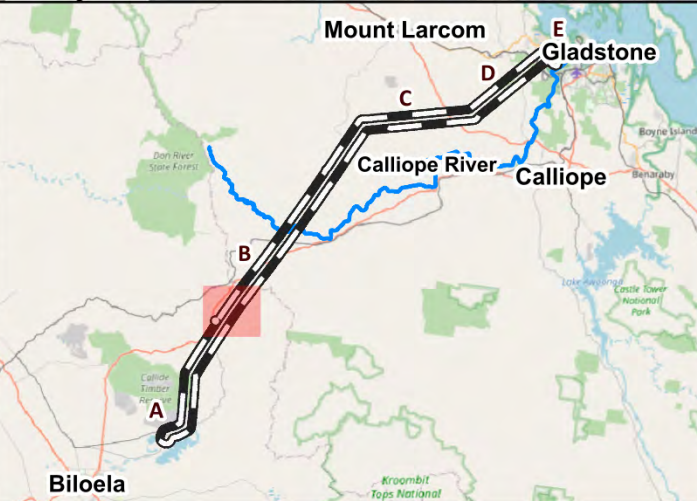
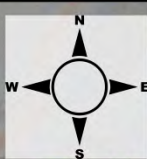

- Legend**
- Project Area
 - Towers
 - 1 m LiDAR Extent
 - Disturbance Footprint
 - Indicative Access Tracks

- Flood depth (m)**
- up to 0.25 m
 - 0.25 to 0.5 m
 - 0.5 to 1.0 m
 - 1.0 to 1.5 m
 - 1.5 to 2.0 m
 - 2.0 to 2.5 m
 - 2.5 to 3.0 m
 - 3.0 to 3.5 m
 - 3.5 to 4.0 m
 - 4.0 to 4.5 m
 - > 4.5 m

Modelling results are based on the best available elevation resolution: Copernicus. The available LiDAR data indicates areas where the elevation and therefore hydraulic model are inconsistent with local survey. All model results should be considered indicative and subject to broader survey validation.

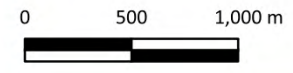

Calvale to Calliope TL Surface Water Impact Assessment

1% AEP Results
Page 5/18



Projection: EPSG:7856
I:\2254-04_C2C-PER_GIS\Amendments\3_GIS\QGIS\2254-04-Alignment_Mapping_agg_Figure_Depth_1p | Exported: 06 March 2026

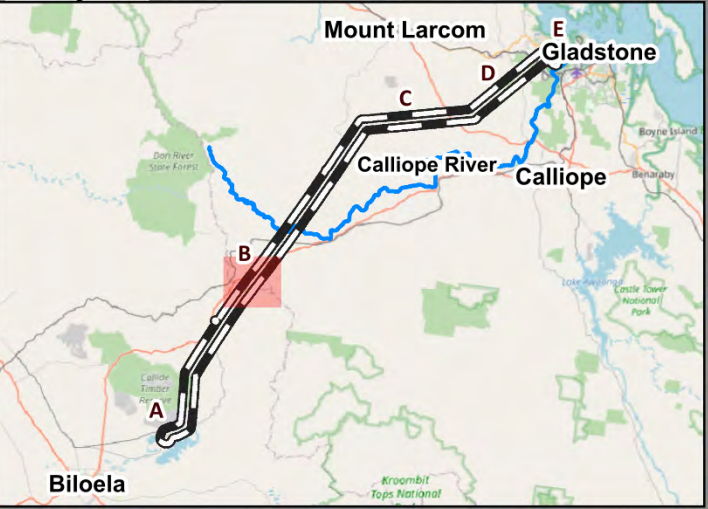

- Legend**
- Project Area
 - Towers
 - 1 m LiDAR Extent
 - Disturbance Footprint
 - Indicative Access Tracks

- Flood depth (m)**
- up to 0.25 m
 - 0.25 to 0.5 m
 - 0.5 to 1.0 m
 - 1.0 to 1.5 m
 - 1.5 to 2.0 m
 - 2.0 to 2.5 m
 - 2.5 to 3.0 m
 - 3.0 to 3.5 m
 - 3.5 to 4.0 m
 - 4.0 to 4.5 m
 - > 4.5 m

Modelling results are based on the best available elevation resolution: Copernicus. The available LiDAR data indicates areas where the elevation and therefore hydraulic model are inconsistent with local survey. All model results should be considered indicative and subject to broader survey validation.



Calvale to Calliope TL Surface Water Impact Assessment

1% AEP Results
Page 6/18



Projection: EPSG:7856
I:\2254-04_C2C-PER_GISAmendments\3_GIS\OGIS\2254-04-Alignment_Mapping_age\Figure_Depth_1p | Exported: 06 March 2026

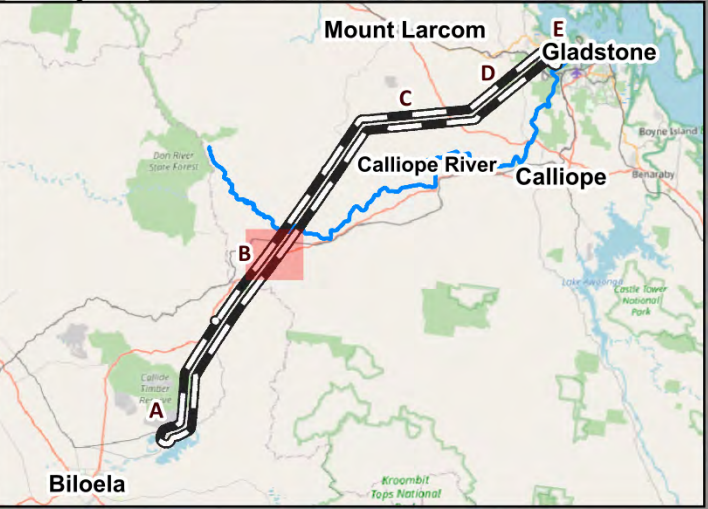

- Legend**
- Project Area
 - Towers
 - 1 m LiDAR Extent
 - Disturbance Footprint
 - Indicative Access Tracks

- Flood depth (m)**
- up to 0.25 m
 - 0.25 to 0.5 m
 - 0.5 to 1.0 m
 - 1.0 to 1.5 m
 - 1.5 to 2.0 m
 - 2.0 to 2.5 m
 - 2.5 to 3.0 m
 - 3.0 to 3.5 m
 - 3.5 to 4.0 m
 - 4.0 to 4.5 m
 - > 4.5 m

Modelling results are based on the best available elevation resolution: Copernicus. The available LiDAR data indicates areas where the elevation and therefore hydraulic model are inconsistent with local survey. All model results should be considered indicative and subject to broader survey validation.

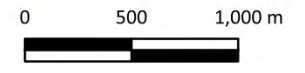

Calvale to Calliope TL Surface Water Impact Assessment

1% AEP Results
Page 7/18



Projection: EPSG:7856
I:\2254-04_C2C-PER_GIS\Amendments\3_GIS\QGIS\2254-04-Alignment_Mapping_age (Figure_Alignment_Depth_1p) (Exported: 06 March 2026)

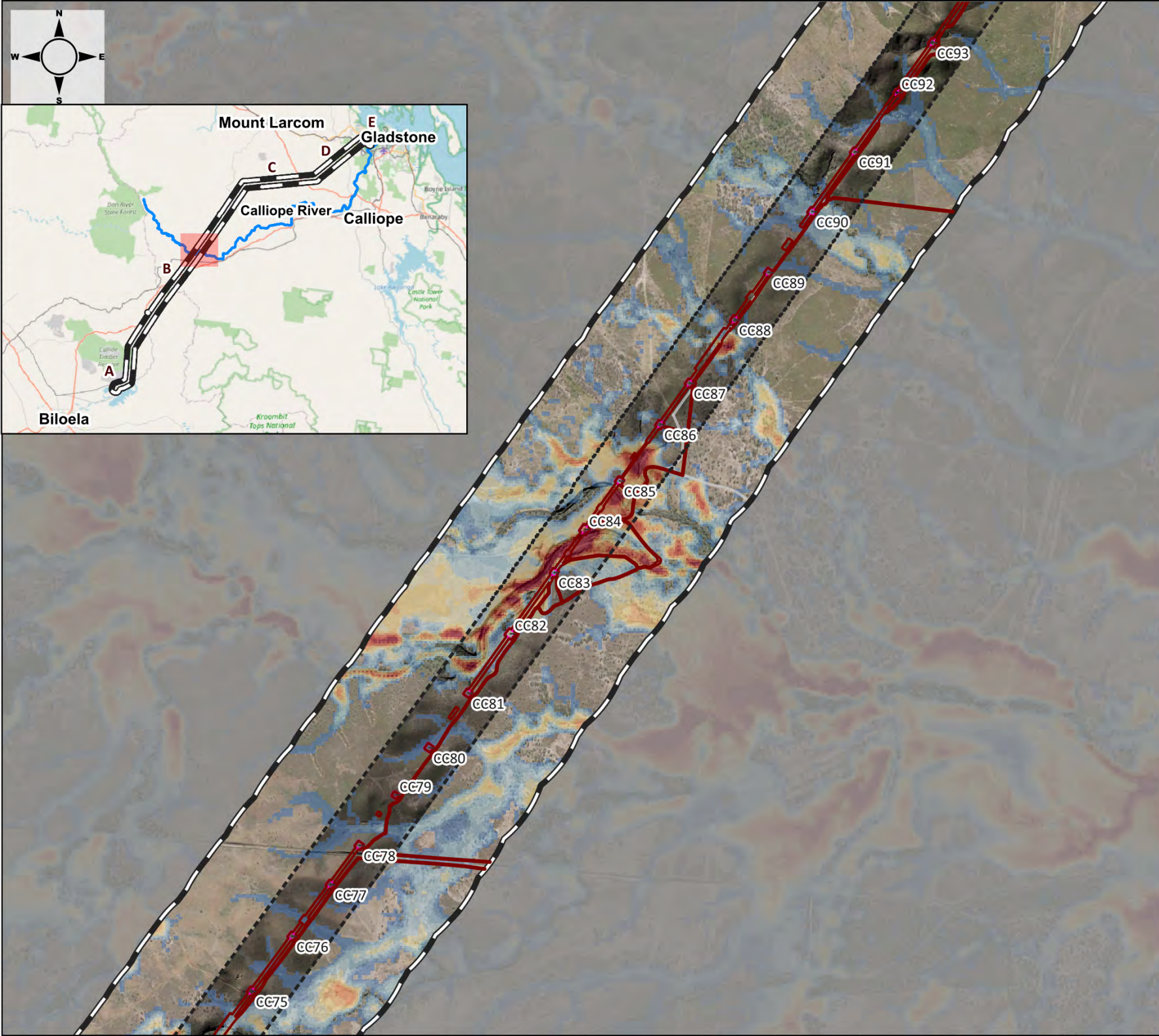

- Legend**
- Project Area
 - Towers
 - 1 m LiDAR Extent
 - Disturbance Footprint
 - Indicative Access Tracks

- Flood depth (m)**
- up to 0.25 m
 - 0.25 to 0.5 m
 - 0.5 to 1.0 m
 - 1.0 to 1.5 m
 - 1.5 to 2.0 m
 - 2.0 to 2.5 m
 - 2.5 to 3.0 m
 - 3.0 to 3.5 m
 - 3.5 to 4.0 m
 - 4.0 to 4.5 m
 - > 4.5 m

Modelling results are based on the best available elevation resolution: Copernicus. The available LiDAR data indicates areas where the elevation and therefore hydraulic model are inconsistent with local survey. All model results should be considered indicative and subject to broader survey validation.

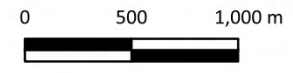

Calvale to Calliope TL Surface Water Impact Assessment

1% AEP Results
Page 8/18



Projection: EPSG:7856
H:\2254-04_C2C-PER_GIS\Amendments\3_GIS\OGIS\2254-04-Alignment_Mapping_agg_Figure_Alignment_Depth_1p | Exported: 06 March 2026



- Legend**
- Project Area
 - Towers
 - 1 m LiDAR Extent
 - Disturbance Footprint
 - Indicative Access Tracks

- Flood depth (m)**
- up to 0.25 m
 - 0.25 to 0.5 m
 - 0.5 to 1.0 m
 - 1.0 to 1.5 m
 - 1.5 to 2.0 m
 - 2.0 to 2.5 m
 - 2.5 to 3.0 m
 - 3.0 to 3.5 m
 - 3.5 to 4.0 m
 - 4.0 to 4.5 m
 - > 4.5 m

Modelling results are based on the best available elevation resolution: Copernicus. The available LiDAR data indicates areas where the elevation and therefore hydraulic model are inconsistent with local survey. All model results should be considered indicative and subject to broader survey validation.

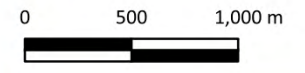

Calvale to Calliope TL Surface Water Impact Assessment

1% AEP Results
Page 9/18



WATER + ENVIRONMENT

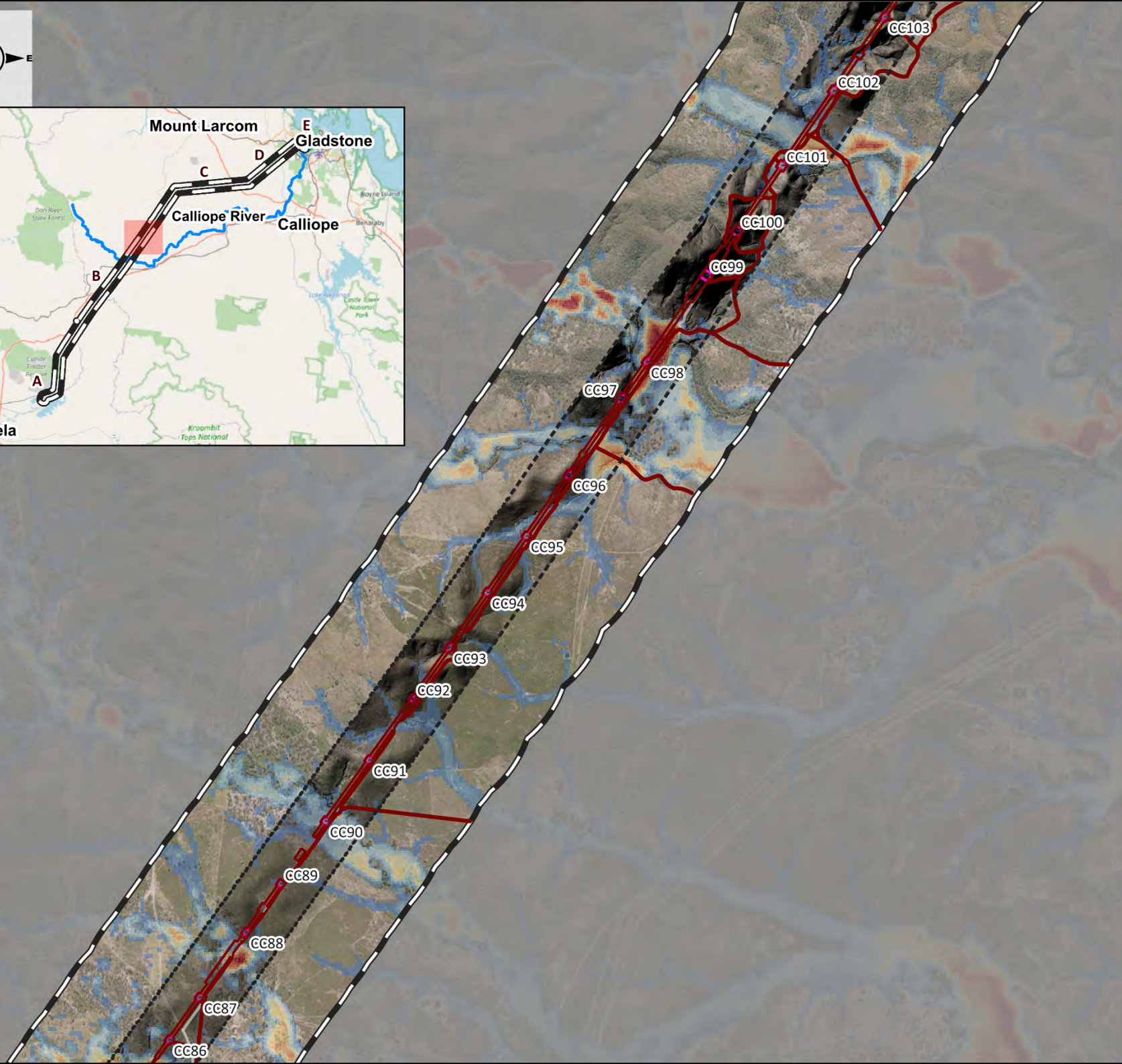

Projection: EPSG:7856
I:\2254-04_C2C-PER_GIS\Amendments\3_GIS\OGIS\2254-04-Alignment_Mapping_agg_Figure_Alignment_Depth_1p | Exported: 06 March 2026



- Legend**
- Project Area
 - Towers
 - 1 m LiDAR Extent
 - Disturbance Footprint
 - Indicative Access Tracks

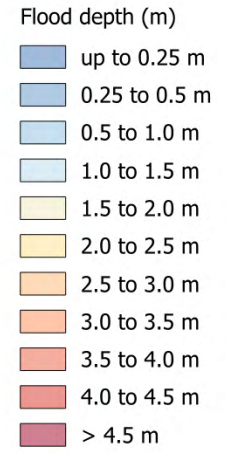

Modelling results are based on the best available elevation resolution: Copernicus. The available LiDAR data indicates areas where the elevation and therefore hydraulic model are inconsistent with local survey. All model results should be considered indicative and subject to broader survey validation.



Calvale to Calliope TL Surface Water Impact Assessment

1% AEP Results
Page 10/18



Projection: EPSG:7856
H:\2254-04_C2C-PER_GISAmendments\3_GIS\OGIS\2254-04-Alignment_Depth_1p | Exported: 06 March 2026

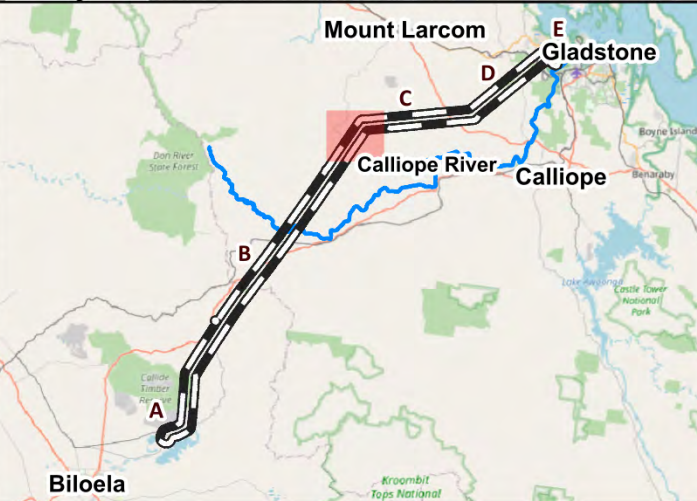

- Legend**
- Project Area
 - Towers
 - 1 m LiDAR Extent
 - Disturbance Footprint
 - Indicative Access Tracks

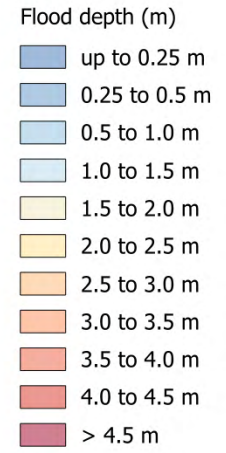

Modelling results are based on the best available elevation resolution: Copernicus. The available LiDAR data indicates areas where the elevation and therefore hydraulic model are inconsistent with local survey. All model results should be considered indicative and subject to broader survey validation.



Calvale to Calliope TL Surface Water Impact Assessment

1% AEP Results
Page 11/18

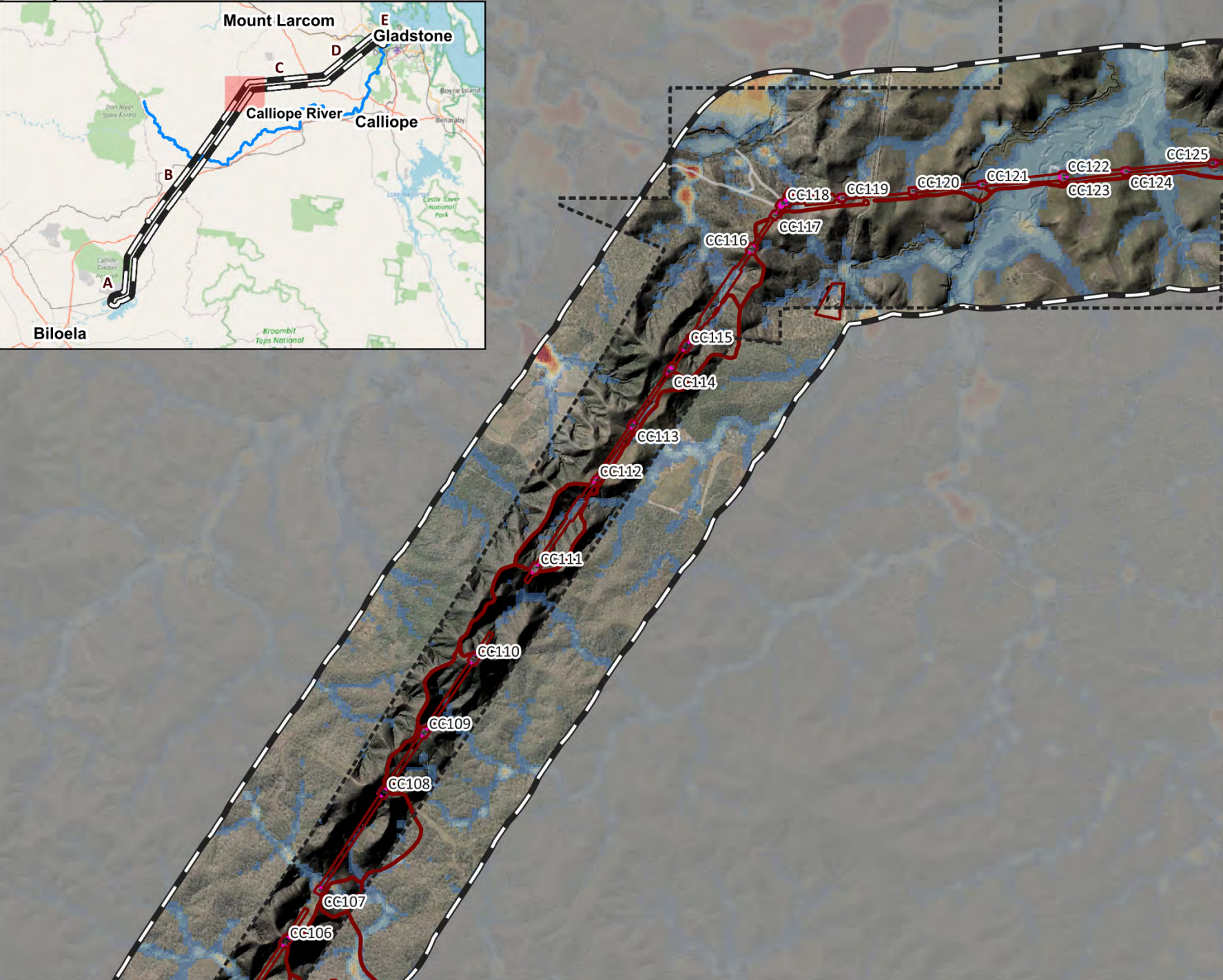

Projection: EPSG:7856
I:\254-04_C2C-PER_GISAmendments\3_GIS\QGIS\254-04-Alignment_Depth_1p | Exported: 06 March 2026

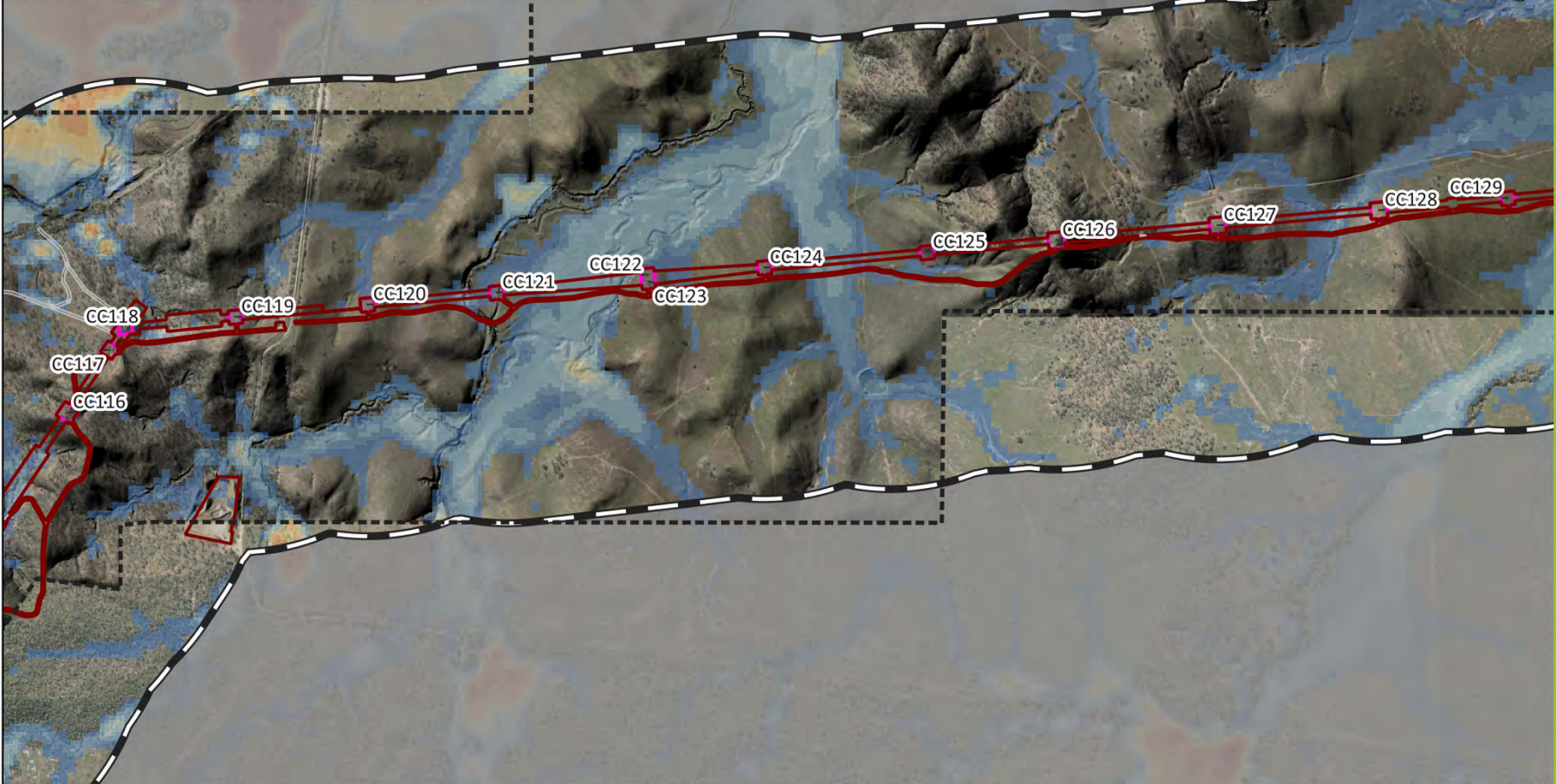

- Legend**
- Project Area
 - Towers
 - 1 m LiDAR Extent
 - Disturbance Footprint
 - Indicative Access Tracks

- Flood depth (m)**
- up to 0.25 m
 - 0.25 to 0.5 m
 - 0.5 to 1.0 m
 - 1.0 to 1.5 m
 - 1.5 to 2.0 m
 - 2.0 to 2.5 m
 - 2.5 to 3.0 m
 - 3.0 to 3.5 m
 - 3.5 to 4.0 m
 - 4.0 to 4.5 m
 - > 4.5 m

Modelling results are based on the best available elevation resolution: Copernicus. The available LiDAR data indicates areas where the elevation and therefore hydraulic model are inconsistent with local survey. All model results should be considered indicative and subject to broader survey validation.

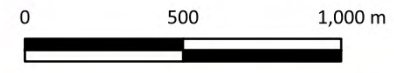

Calvale to Calliope TL Surface Water Impact Assessment

1% AEP Results
Page 12/18



Projection: EPSG:7856
I:\254-04_C2C-FER_GISAmendments\3_GIS\QGIS\254-04-Alignment_Mapping_age\Figure_Alignment_Depth_1p | Exported: 06 March 2026

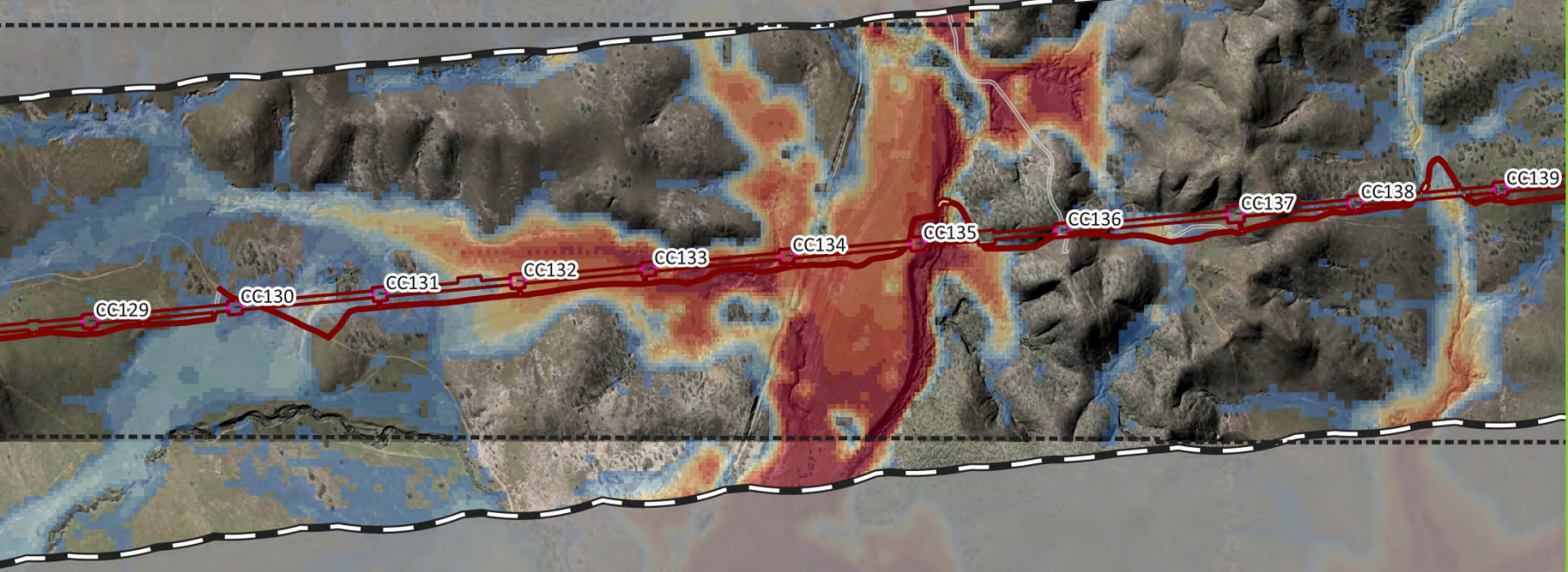
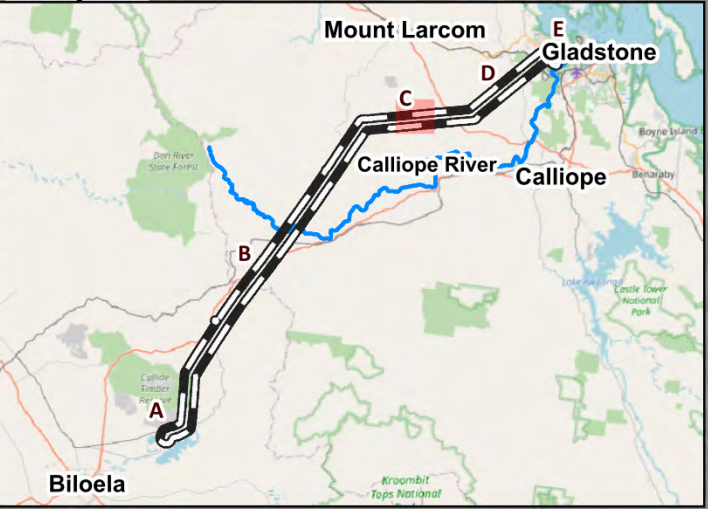

- Legend**
- Project Area
 - Towers
 - 1 m LiDAR Extent
 - Disturbance Footprint
 - Indicative Access Tracks

- Flood depth (m)**
- up to 0.25 m
 - 0.25 to 0.5 m
 - 0.5 to 1.0 m
 - 1.0 to 1.5 m
 - 1.5 to 2.0 m
 - 2.0 to 2.5 m
 - 2.5 to 3.0 m
 - 3.0 to 3.5 m
 - 3.5 to 4.0 m
 - 4.0 to 4.5 m
 - > 4.5 m

Modelling results are based on the best available elevation resolution: Copernicus. The available LiDAR data indicates areas where the elevation and therefore hydraulic model are inconsistent with local survey. All model results should be considered indicative and subject to broader survey validation.



Calvale to Calliope TL Surface Water Impact Assessment

1% AEP Results
Page 13/18



Projection: EPSG:7856
I:\254-04_C2C-PER_GIS\Amendments\3_GIS\QGIS\254-04-Alignment_Mapping_agg_Figure_Alignment_Depth_1ip | Exported: 06 March 2026

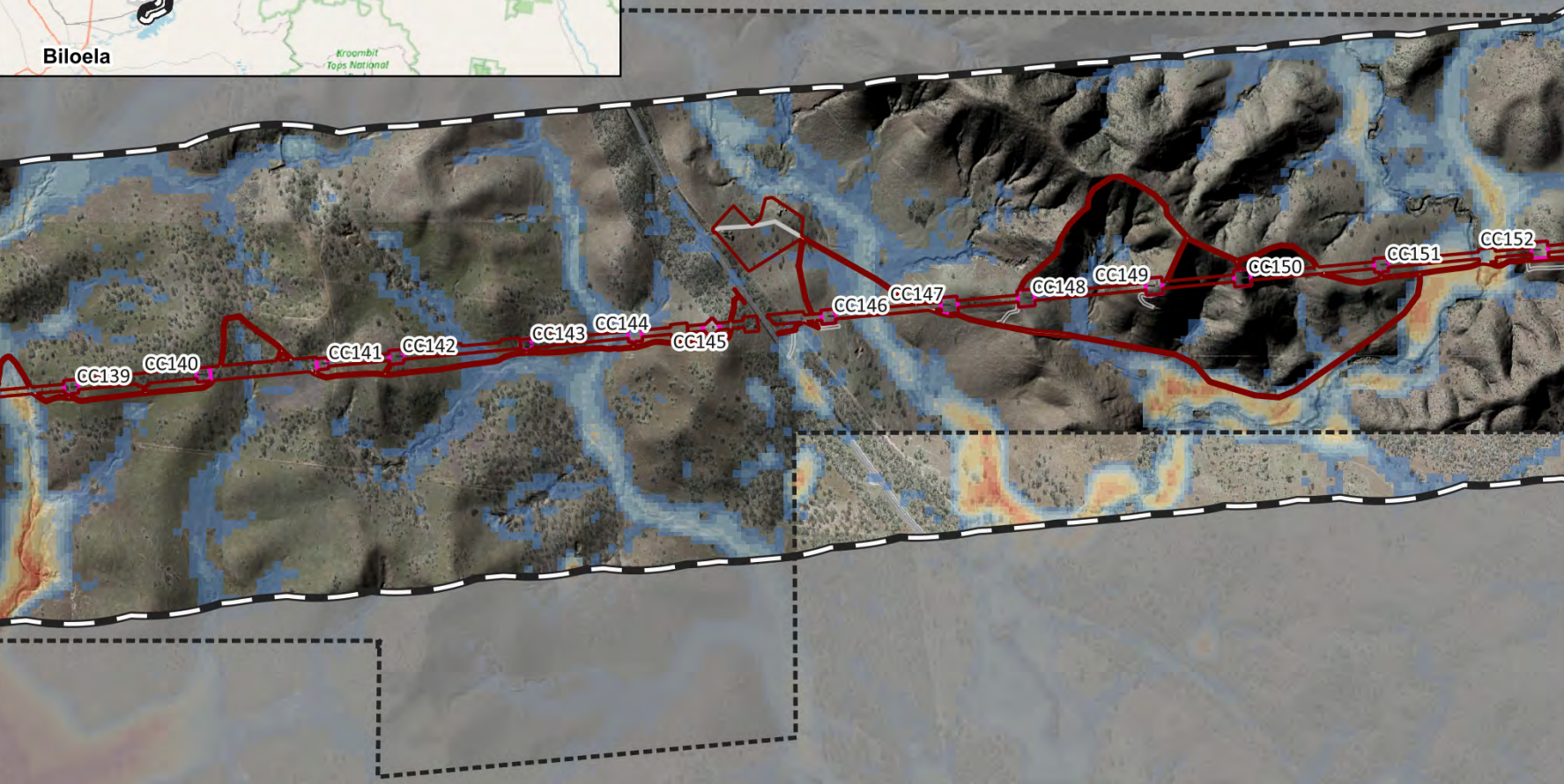
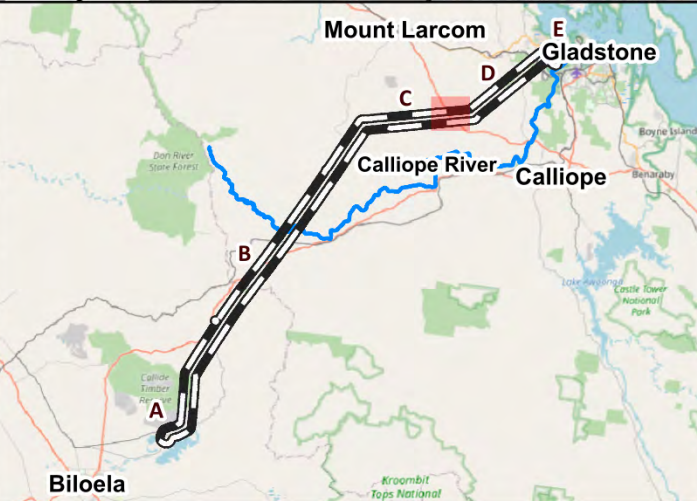

- Legend**
- Project Area
 - Towers
 - 1 m LiDAR Extent
 - Disturbance Footprint
 - Indicative Access Tracks

- Flood depth (m)**
- up to 0.25 m
 - 0.25 to 0.5 m
 - 0.5 to 1.0 m
 - 1.0 to 1.5 m
 - 1.5 to 2.0 m
 - 2.0 to 2.5 m
 - 2.5 to 3.0 m
 - 3.0 to 3.5 m
 - 3.5 to 4.0 m
 - 4.0 to 4.5 m
 - > 4.5 m

Modelling results are based on the best available elevation resolution: Copernicus. The available LiDAR data indicates areas where the elevation and therefore hydraulic model are inconsistent with local survey. All model results should be considered indicative and subject to broader survey validation.

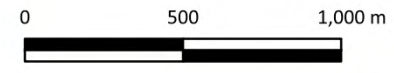

Calvale to Calliope TL Surface Water Impact Assessment

1% AEP Results
Page 14/18



Projection: EPSG:7856
I:\2254-04_C2C-PER_GISAmendments\3_GIS\QGIS\2254-04-Alignment_Mapping_agg_Figure_Depth_1p | Exported: 06 March 2026

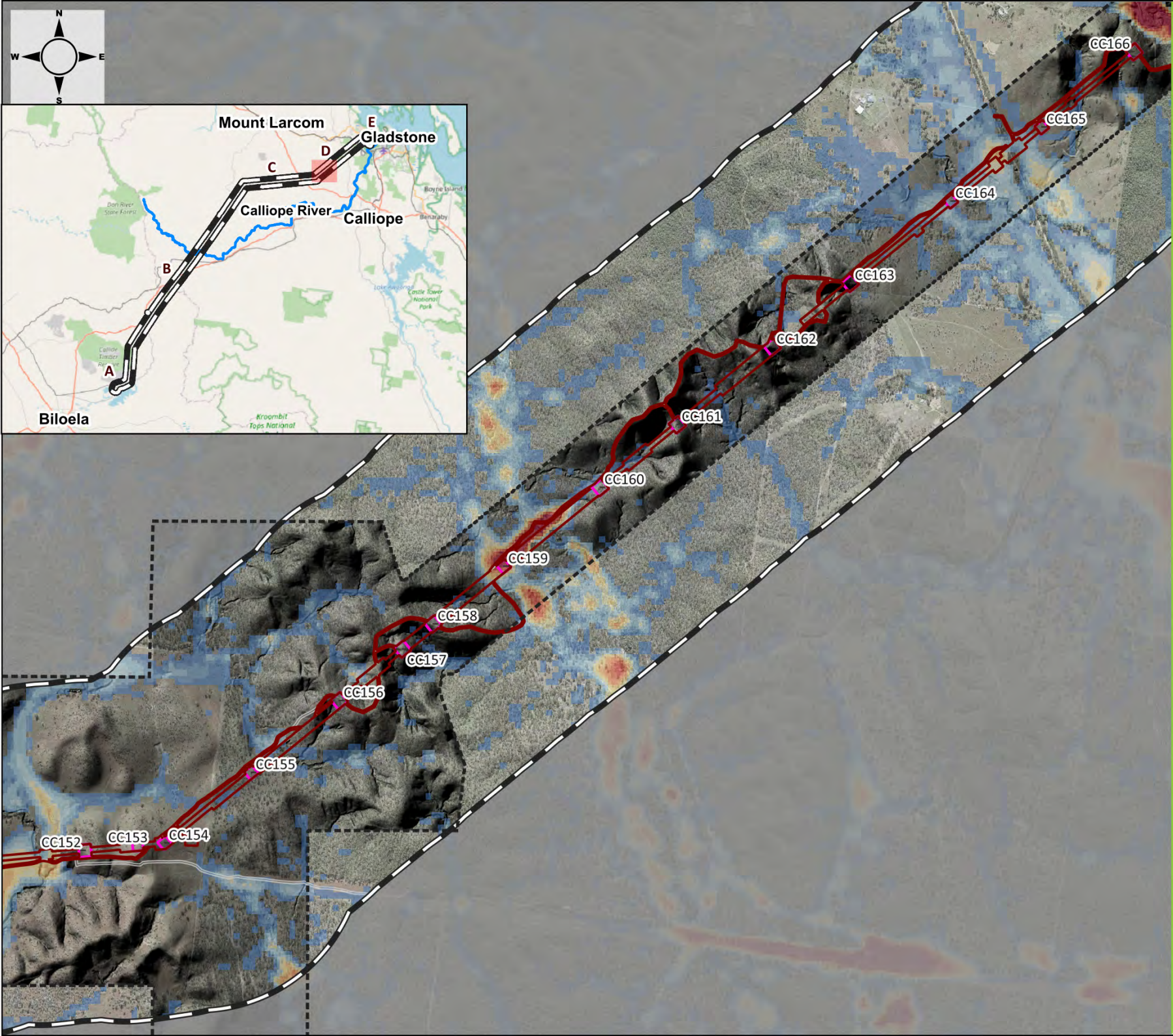

- Legend**
- Project Area
 - Towers
 - 1 m LiDAR Extent
 - Disturbance Footprint
 - Indicative Access Tracks

- Flood depth (m)**
- up to 0.25 m
 - 0.25 to 0.5 m
 - 0.5 to 1.0 m
 - 1.0 to 1.5 m
 - 1.5 to 2.0 m
 - 2.0 to 2.5 m
 - 2.5 to 3.0 m
 - 3.0 to 3.5 m
 - 3.5 to 4.0 m
 - 4.0 to 4.5 m
 - > 4.5 m

Modelling results are based on the best available elevation resolution: Copernicus. The available LiDAR data indicates areas where the elevation and therefore hydraulic model are inconsistent with local survey. All model results should be considered indicative and subject to broader survey validation.

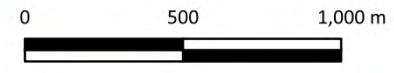

Calvale to Calliope TL Surface Water Impact Assessment

1% AEP Results
Page 15/18



Projection: EPSG:7856
I:\2254-04_C2C-PER_GIS\Amendments\3_GIS\QGIS\2254-04-Alignment_Mapping_age\Figure_Aggs\Depth_1p | Exported: 06 March 2026

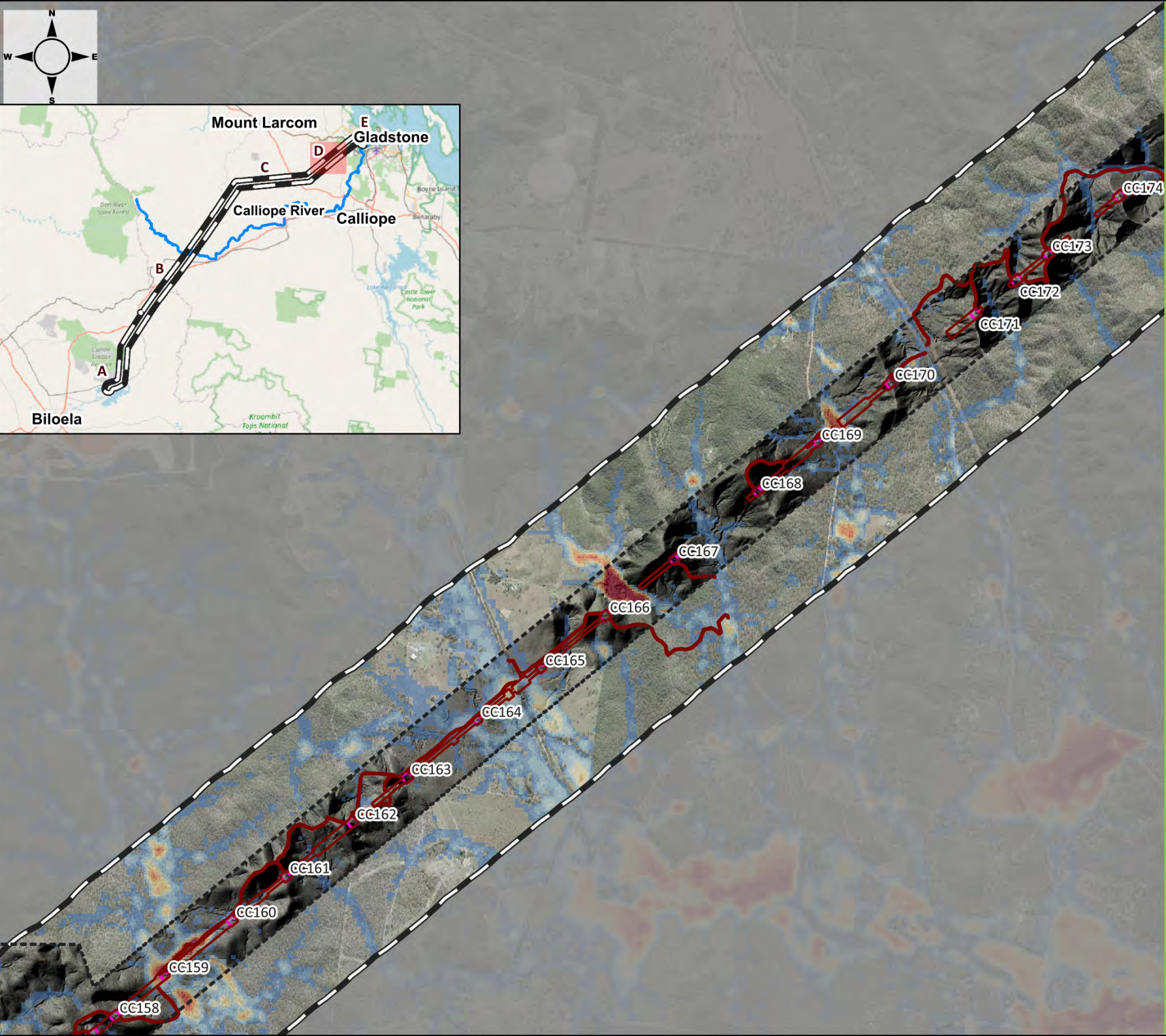
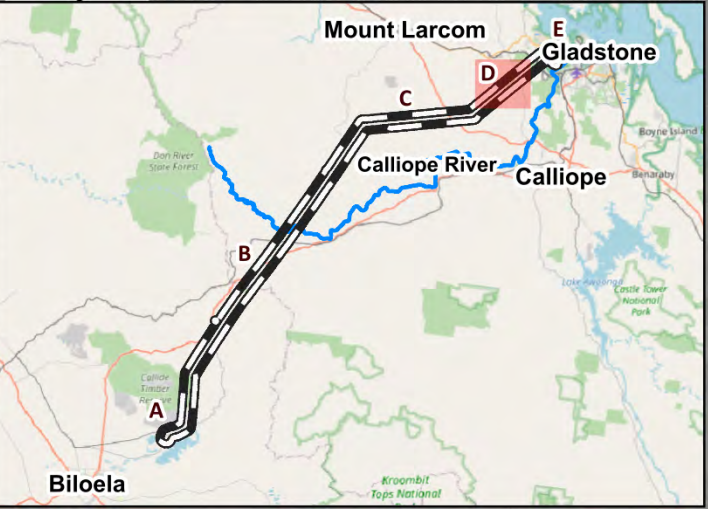

- Legend**
- Project Area
 - Towers
 - 1 m LiDAR Extent
 - Disturbance Footprint
 - Indicative Access Tracks

- Flood depth (m)**
- up to 0.25 m
 - 0.25 to 0.5 m
 - 0.5 to 1.0 m
 - 1.0 to 1.5 m
 - 1.5 to 2.0 m
 - 2.0 to 2.5 m
 - 2.5 to 3.0 m
 - 3.0 to 3.5 m
 - 3.5 to 4.0 m
 - 4.0 to 4.5 m
 - > 4.5 m

Modelling results are based on the best available elevation resolution: Copernicus. The available LiDAR data indicates areas where the elevation and therefore hydraulic model are inconsistent with local survey. All model results should be considered indicative and subject to broader survey validation.

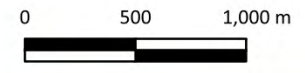

Calvale to Calliope TL Surface Water Impact Assessment

1% AEP Results
Page 16/18



Projection: EPSG:7856
I:\2254-04_C2C-PER_GIS\Amendments\3_GIS\OGIS\2254-04-Alignment_Mapping_age\Figure_Alignment_Depth_1p | Exported: 06 March 2026

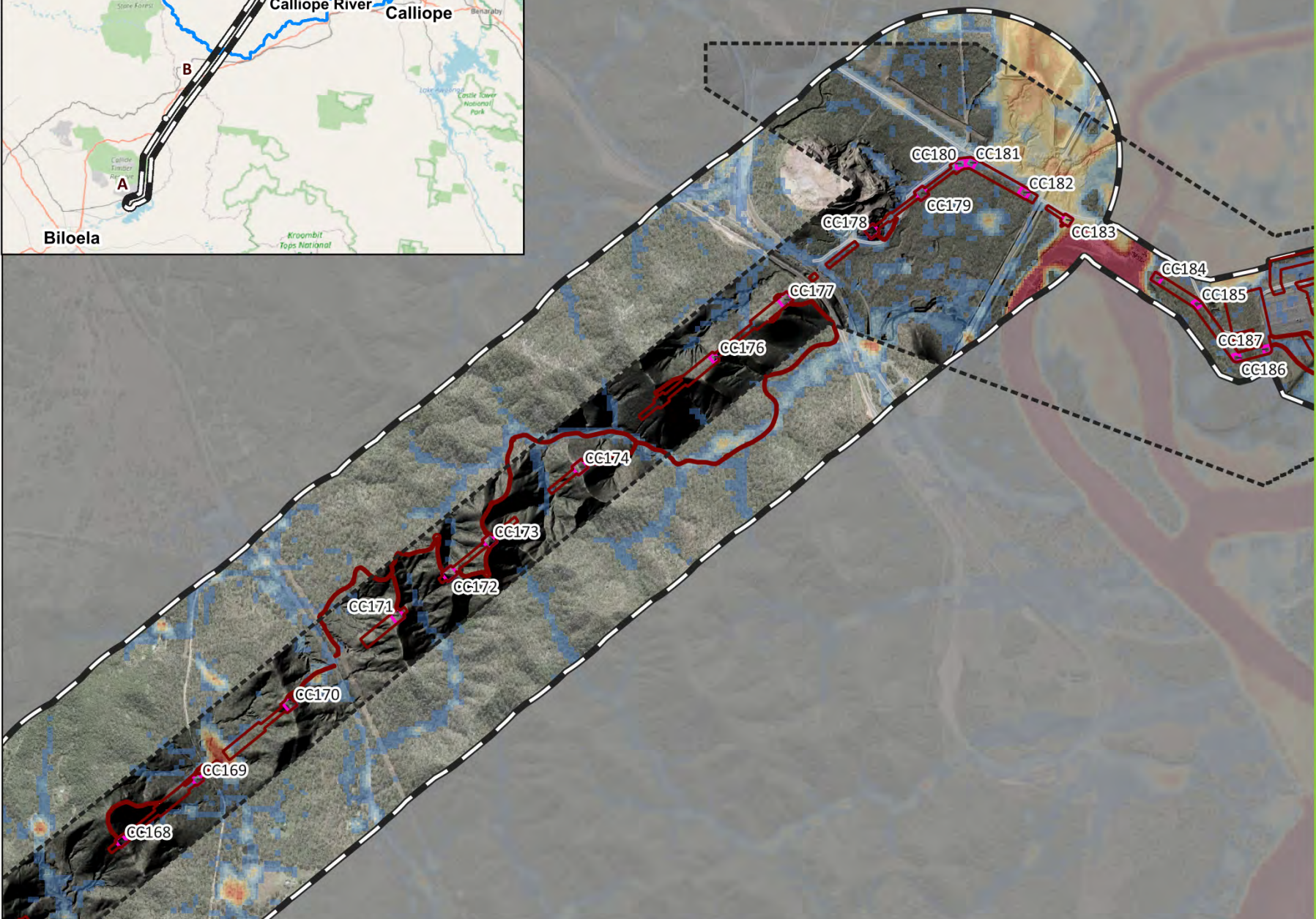

- Legend
- Project Area
 - Towers
 - 1 m LiDAR Extent
 - Disturbance Footprint
 - Indicative Access Tracks

- Flood depth (m)
- up to 0.25 m
 - 0.25 to 0.5 m
 - 0.5 to 1.0 m
 - 1.0 to 1.5 m
 - 1.5 to 2.0 m
 - 2.0 to 2.5 m
 - 2.5 to 3.0 m
 - 3.0 to 3.5 m
 - 3.5 to 4.0 m
 - 4.0 to 4.5 m
 - > 4.5 m

Modelling results are based on the best available elevation resolution: Copernicus. The available LiDAR data indicates areas where the elevation and therefore hydraulic model are inconsistent with local survey. All model results should be considered indicative and subject to broader survey validation.

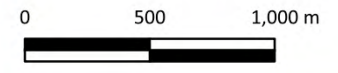

Calvale to Calliope TL Surface Water Impact Assessment

1% AEP Results
Page 17/18



Projection: EPSG:7856
I:\2254-04_C2C-PER_GIS\Amendments\3_GIS\QGIS\2254-04-Alignment_Mapping_agez (Figure_Alignment_Depth_1p) (Exported: 06 March 2026)

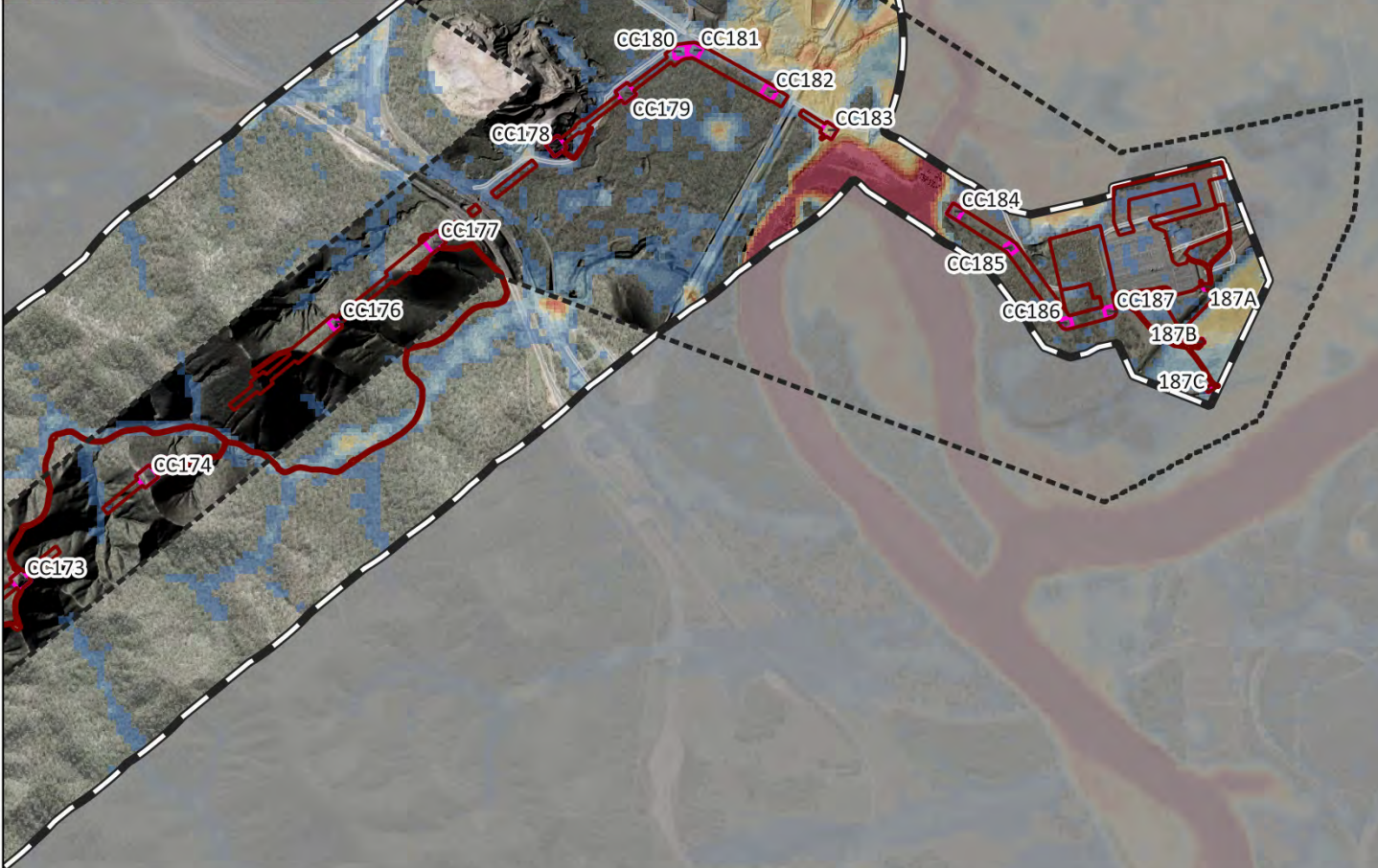

- Legend**
- Project Area
 - Towers
 - 1 m LiDAR Extent
 - Disturbance Footprint
 - Indicative Access Tracks

- Flood depth (m)**
- up to 0.25 m
 - 0.25 to 0.5 m
 - 0.5 to 1.0 m
 - 1.0 to 1.5 m
 - 1.5 to 2.0 m
 - 2.0 to 2.5 m
 - 2.5 to 3.0 m
 - 3.0 to 3.5 m
 - 3.5 to 4.0 m
 - 4.0 to 4.5 m
 - > 4.5 m

Modelling results are based on the best available elevation resolution: Copernicus. The available LiDAR data indicates areas where the elevation and therefore hydraulic model are inconsistent with local survey. All model results should be considered indicative and subject to broader survey validation.



Calvale to Calliope TL Surface Water Impact Assessment

1% AEP Results
Page 18/18



B.3 REGIONAL FLOOD MAPPING – FUTURE CLIMATE 2090 SSP3

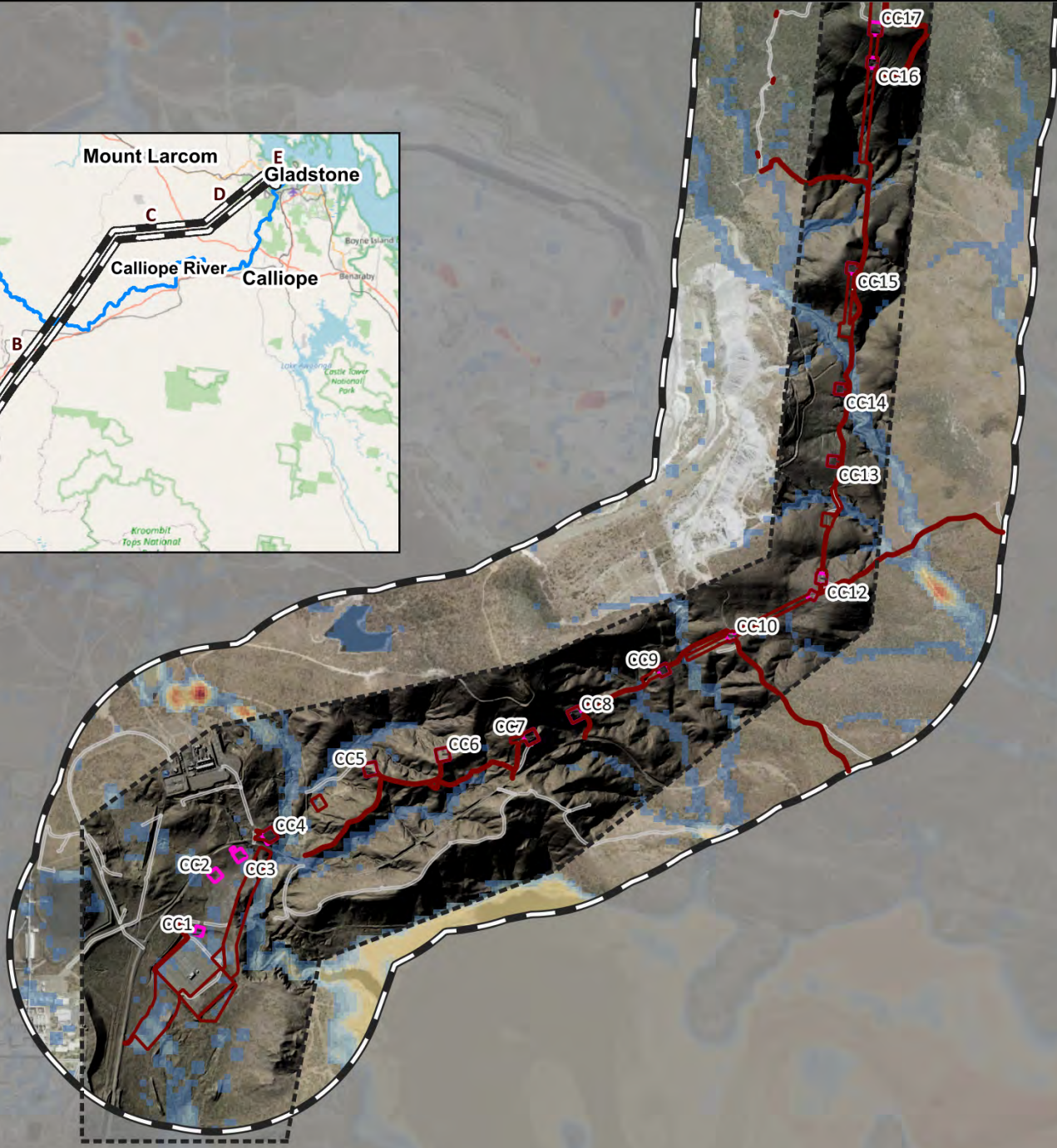

- Legend**
- Project Area
 - Towers
 - 1 m LiDAR Extent
 - Disturbance Footprint
 - Indicative Access Tracks

- Flood depth (m)**
- up to 0.25 m
 - 0.25 to 0.5 m
 - 0.5 to 1.0 m
 - 1.0 to 1.5 m
 - 1.5 to 2.0 m
 - 2.0 to 2.5 m
 - 2.5 to 3.0 m
 - 3.0 to 3.5 m
 - 3.5 to 4.0 m
 - 4.0 to 4.5 m
 - > 4.5 m

Modelling results are based on the best available elevation resolution: Copernicus. The available LiDAR data indicates areas where the elevation and therefore hydraulic model are inconsistent with local survey. All model results should be considered indicative and subject to broader survey validation.

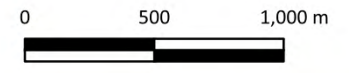

Calvale to Calliope TL Surface Water Impact Assessment

10% AEP 2090-SSP3 Results
Page 1/18



J:\2254-04_C2C-PEP_GISA\Amendments\3_GIS\GIS\2254-04-Alignment_Mapping.qgz (Figure_Alignment_Depth_10p_CC) (Exported: 06 March 2026)
Projection: EPSG:7856

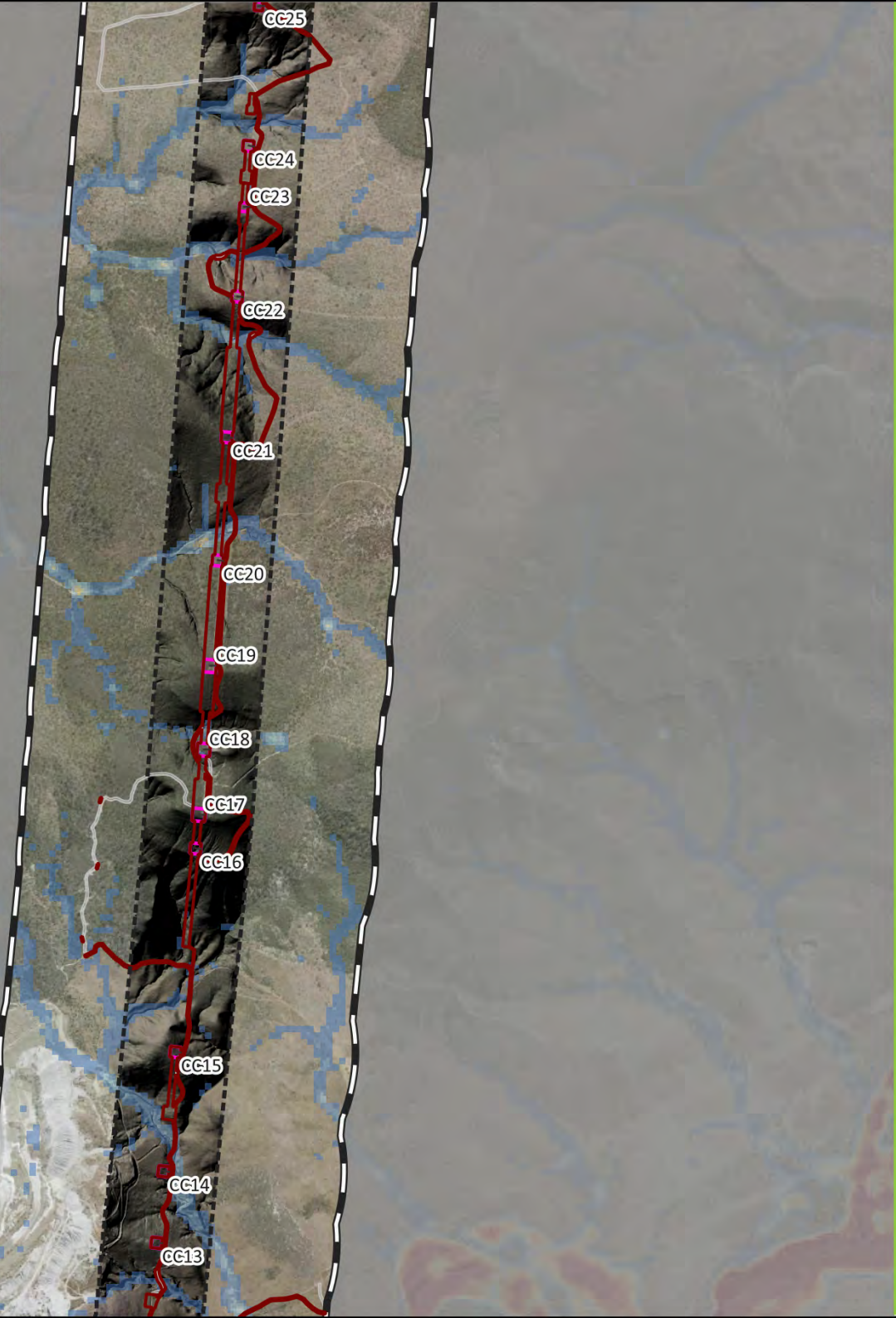
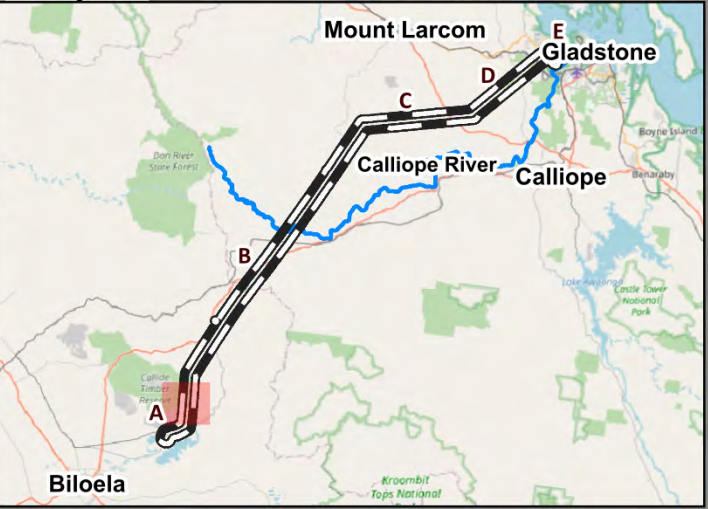

- Legend**
- Project Area
 - Towers
 - 1 m LiDAR Extent
 - Disturbance Footprint
 - Indicative Access Tracks

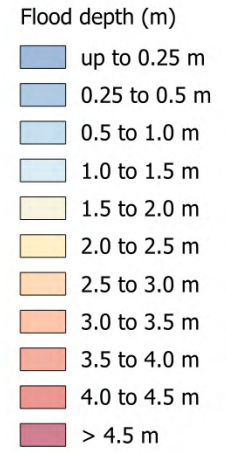

Modelling results are based on the best available elevation resolution: Copernicus. The available LiDAR data indicates areas where the elevation and therefore hydraulic model are inconsistent with local survey. All model results should be considered indicative and subject to broader survey validation.

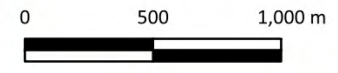

Calvale to Calliope TL Surface Water Impact Assessment

10% AEP 2090-SSP3 Results
Page 2/18



J:\2254-04_C2C-PEP_GISA\Amendments\3_GIS\GIS\2254-04-Alignment_Mapping.qgz (Figure_Alignment_Depth_10p_CC) (Exported: 06 March 2026)
Projection: EPSG:7856

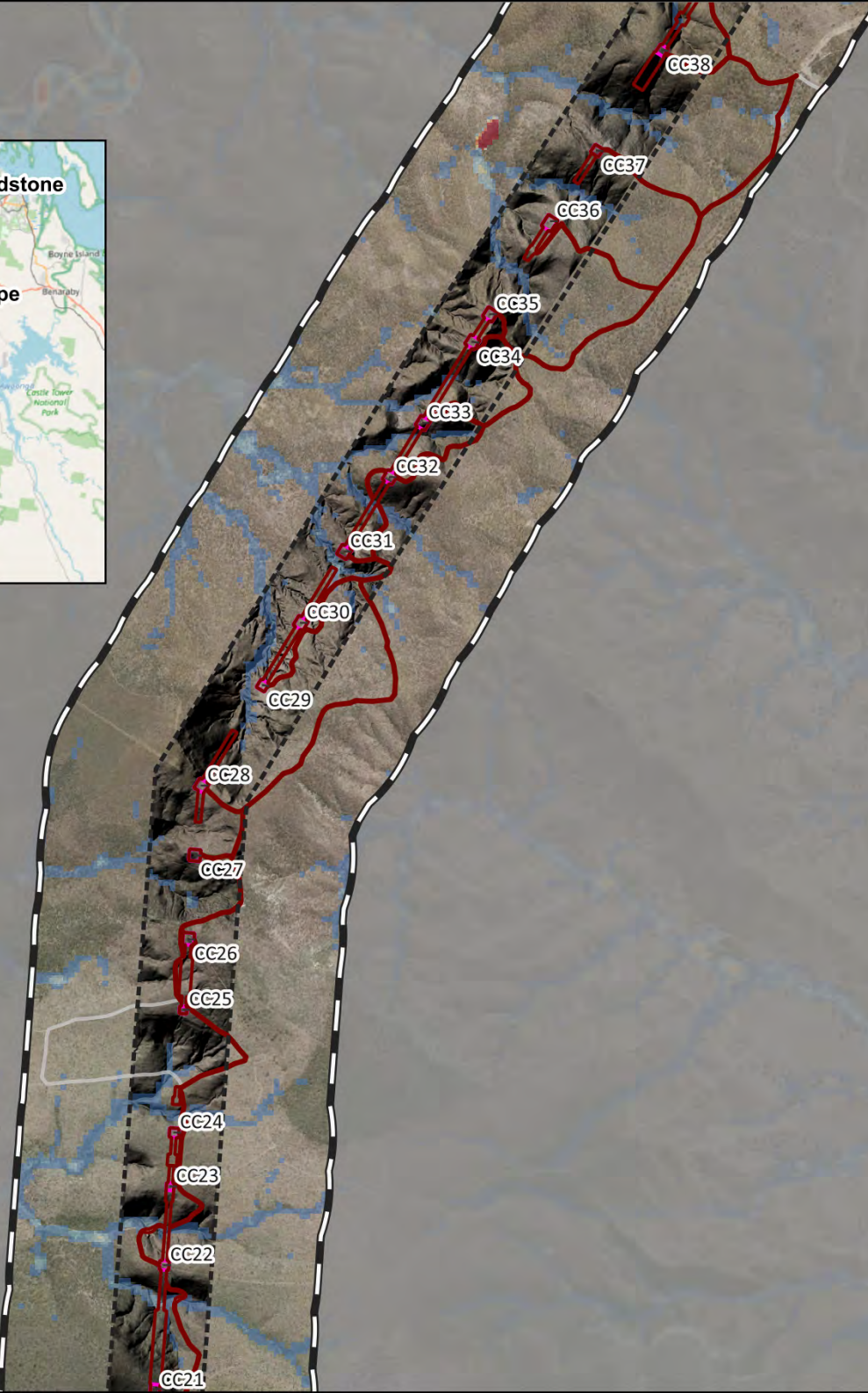

- Legend
- Project Area
 - Towers
 - 1 m LiDAR Extent
 - Disturbance Footprint
 - Indicative Access Tracks

- Flood depth (m)
- up to 0.25 m
 - 0.25 to 0.5 m
 - 0.5 to 1.0 m
 - 1.0 to 1.5 m
 - 1.5 to 2.0 m
 - 2.0 to 2.5 m
 - 2.5 to 3.0 m
 - 3.0 to 3.5 m
 - 3.5 to 4.0 m
 - 4.0 to 4.5 m
 - > 4.5 m

Modelling results are based on the best available elevation resolution: Copernicus. The available LiDAR data indicates areas where the elevation and therefore hydraulic model are inconsistent with local survey. All model results should be considered indicative and subject to broader survey validation.

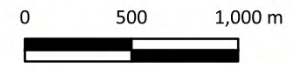

Calvale to Calliope TL Surface Water Impact Assessment

10% AEP 2090-SSP3 Results
Page 3/18



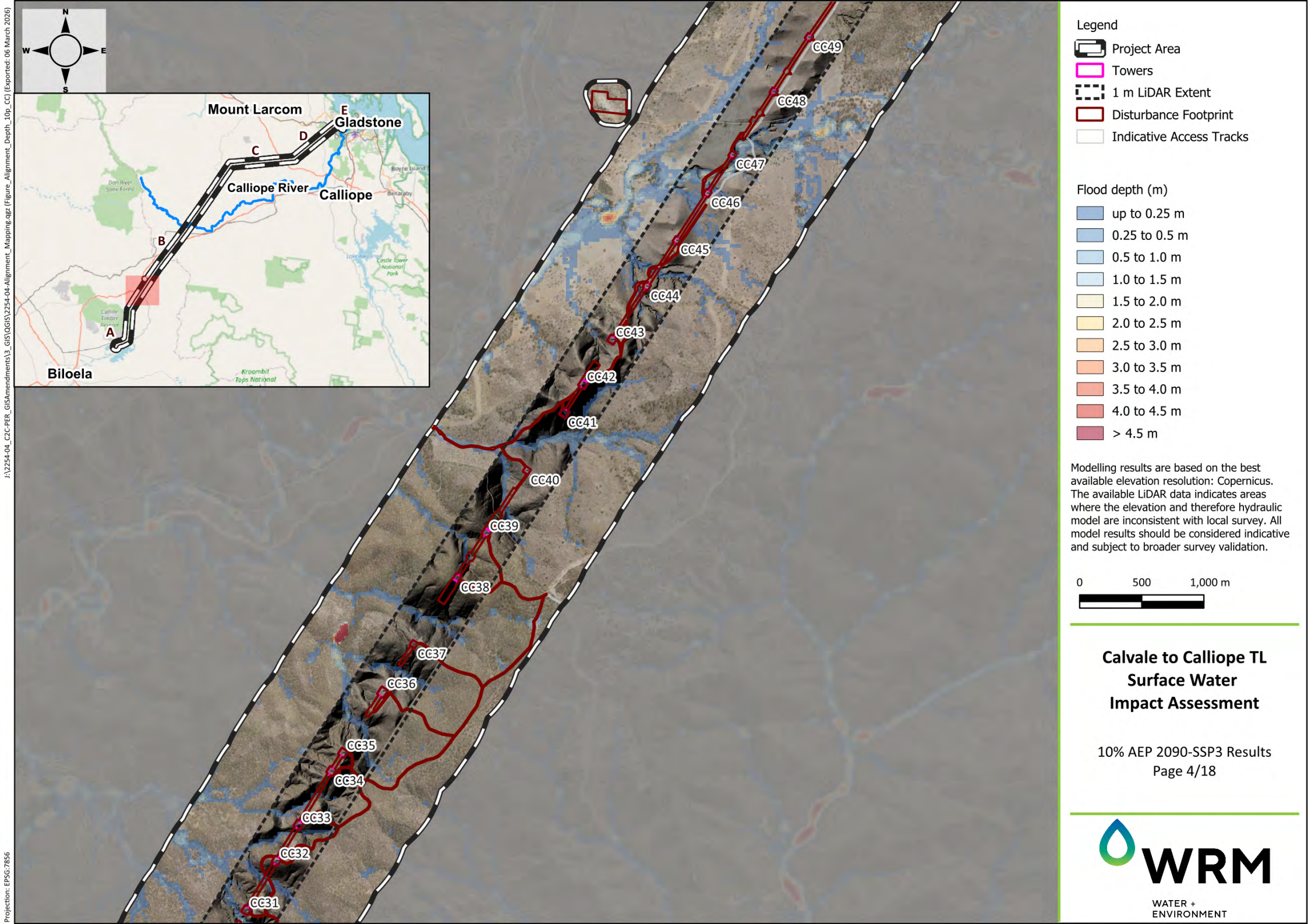

- Legend**
- Project Area
 - Towers
 - 1 m LiDAR Extent
 - Disturbance Footprint
 - Indicative Access Tracks

- Flood depth (m)**
- up to 0.25 m
 - 0.25 to 0.5 m
 - 0.5 to 1.0 m
 - 1.0 to 1.5 m
 - 1.5 to 2.0 m
 - 2.0 to 2.5 m
 - 2.5 to 3.0 m
 - 3.0 to 3.5 m
 - 3.5 to 4.0 m
 - 4.0 to 4.5 m
 - > 4.5 m

Modelling results are based on the best available elevation resolution: Copernicus. The available LiDAR data indicates areas where the elevation and therefore hydraulic model are inconsistent with local survey. All model results should be considered indicative and subject to broader survey validation.

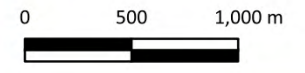

**Calvale to Calliope TL
Surface Water
Impact Assessment**

10% AEP 2090-SSP3 Results
Page 4/18



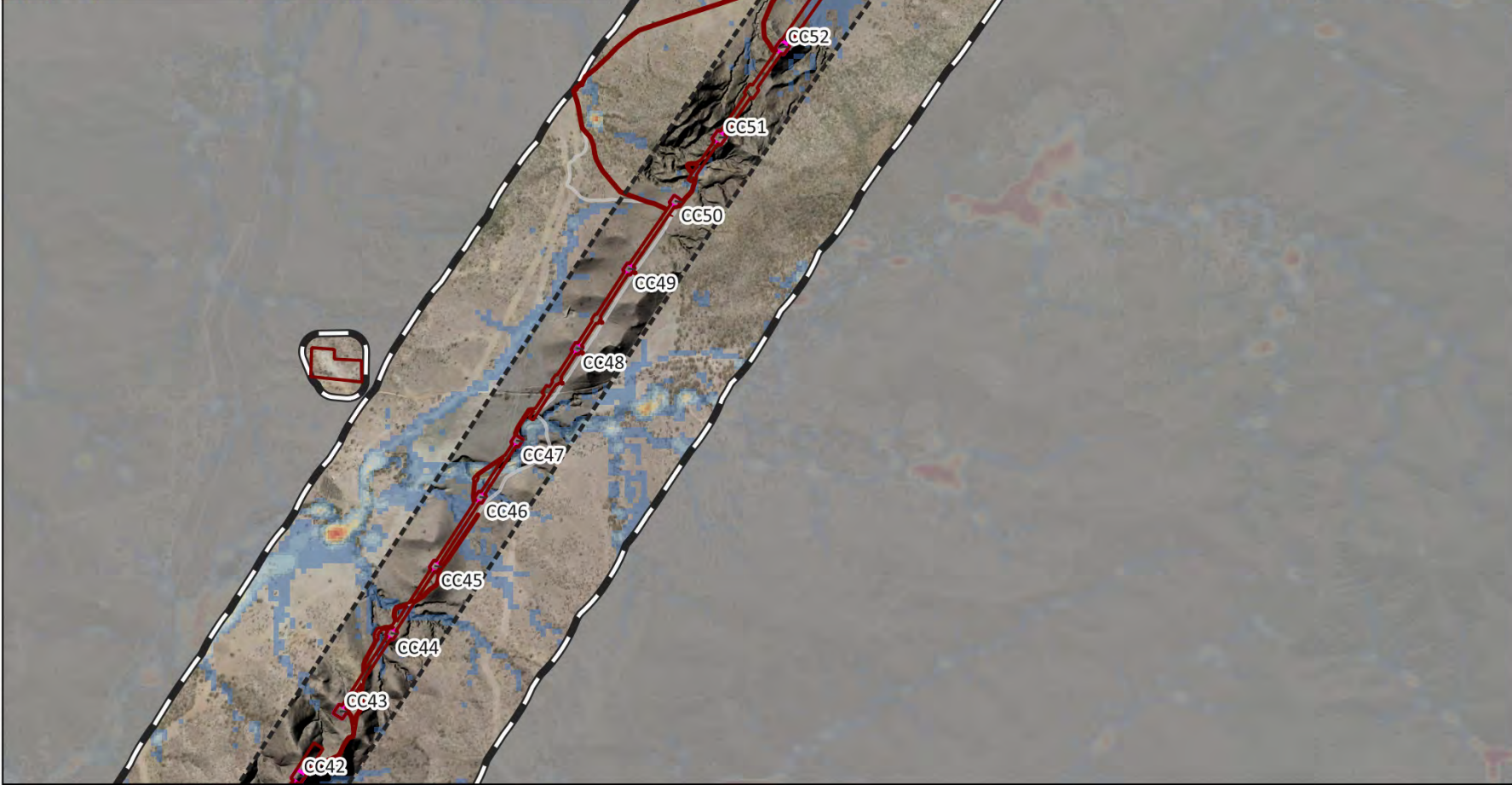

- Legend**
- Project Area
 - Towers
 - 1 m LiDAR Extent
 - Disturbance Footprint
 - Indicative Access Tracks

- Flood depth (m)**
- up to 0.25 m
 - 0.25 to 0.5 m
 - 0.5 to 1.0 m
 - 1.0 to 1.5 m
 - 1.5 to 2.0 m
 - 2.0 to 2.5 m
 - 2.5 to 3.0 m
 - 3.0 to 3.5 m
 - 3.5 to 4.0 m
 - 4.0 to 4.5 m
 - > 4.5 m

Modelling results are based on the best available elevation resolution: Copernicus. The available LiDAR data indicates areas where the elevation and therefore hydraulic model are inconsistent with local survey. All model results should be considered indicative and subject to broader survey validation.

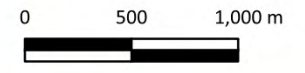

Calvale to Calliope TL Surface Water Impact Assessment

10% AEP 2090-SSP3 Results
Page 5/18



J:\2254-04_C2C-PEP_GISA\amendments\3_GIS\GIS\2254-04-Alignment_Mapping.qgz (Figure_Alignment_Depth_10p_CC) (Exported: 06 March 2026)
Projection: EPSG:7856



- Legend**
- Project Area
 - Towers
 - 1 m LiDAR Extent
 - Disturbance Footprint
 - Indicative Access Tracks

- Flood depth (m)**
- up to 0.25 m
 - 0.25 to 0.5 m
 - 0.5 to 1.0 m
 - 1.0 to 1.5 m
 - 1.5 to 2.0 m
 - 2.0 to 2.5 m
 - 2.5 to 3.0 m
 - 3.0 to 3.5 m
 - 3.5 to 4.0 m
 - 4.0 to 4.5 m
 - > 4.5 m

Modelling results are based on the best available elevation resolution: Copernicus. The available LiDAR data indicates areas where the elevation and therefore hydraulic model are inconsistent with local survey. All model results should be considered indicative and subject to broader survey validation.



Calvale to Calliope TL Surface Water Impact Assessment

10% AEP 2090-SSP3 Results
Page 6/18



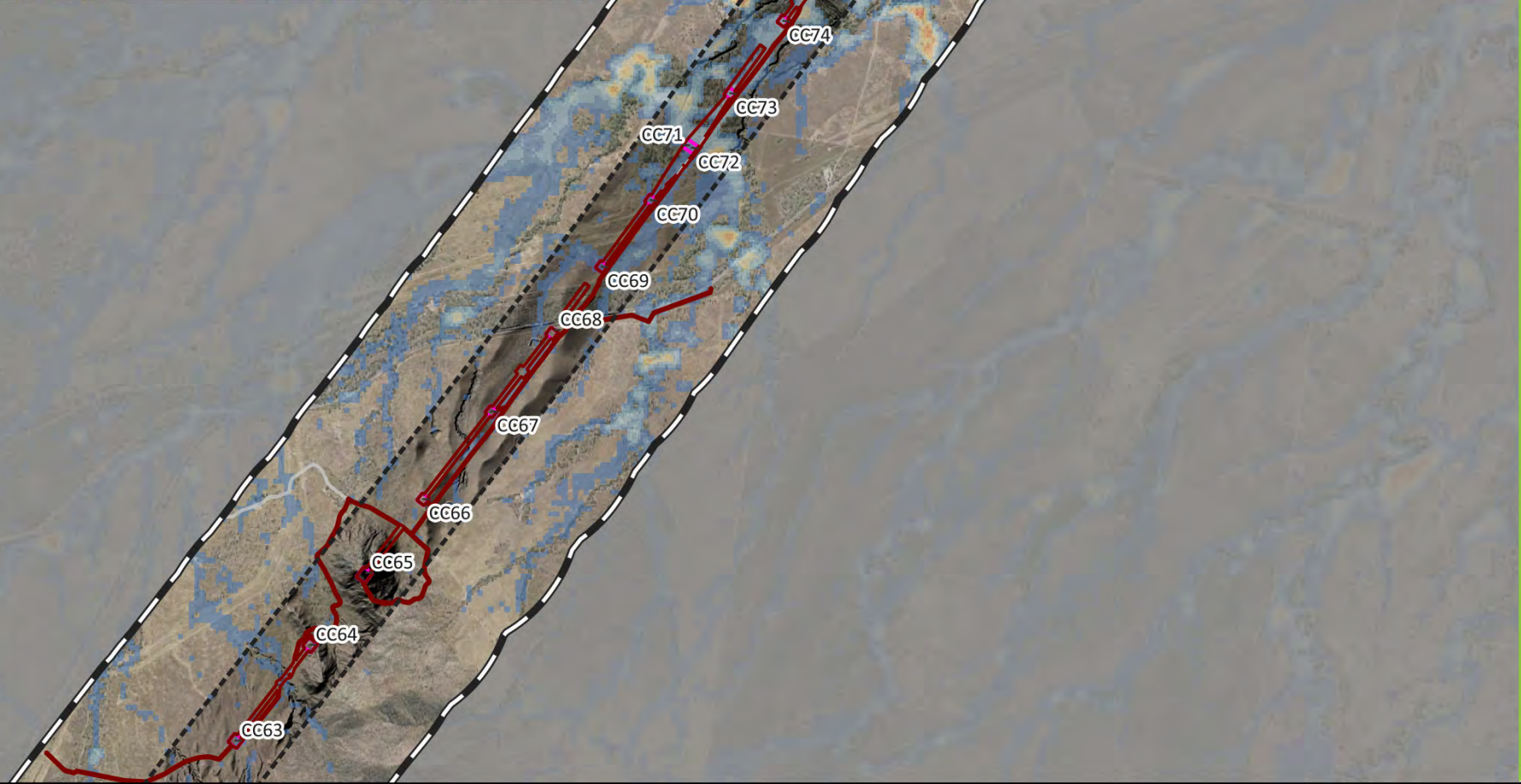
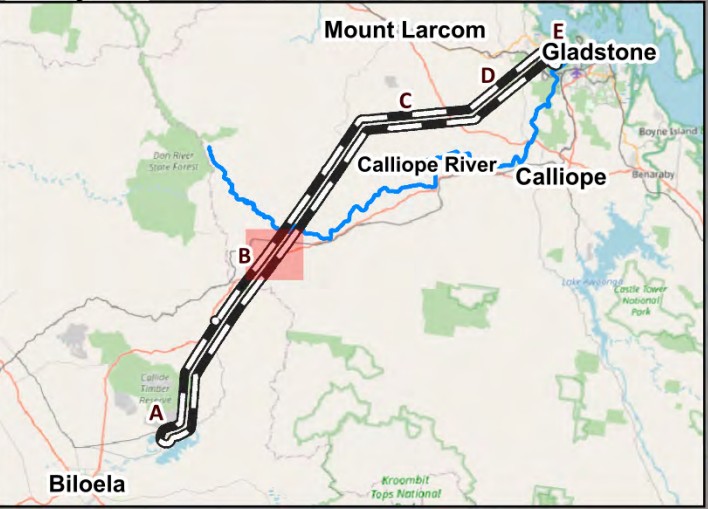

- Legend**
- Project Area
 - Towers
 - 1 m LiDAR Extent
 - Disturbance Footprint
 - Indicative Access Tracks

- Flood depth (m)**
- up to 0.25 m
 - 0.25 to 0.5 m
 - 0.5 to 1.0 m
 - 1.0 to 1.5 m
 - 1.5 to 2.0 m
 - 2.0 to 2.5 m
 - 2.5 to 3.0 m
 - 3.0 to 3.5 m
 - 3.5 to 4.0 m
 - 4.0 to 4.5 m
 - > 4.5 m

Modelling results are based on the best available elevation resolution: Copernicus. The available LiDAR data indicates areas where the elevation and therefore hydraulic model are inconsistent with local survey. All model results should be considered indicative and subject to broader survey validation.

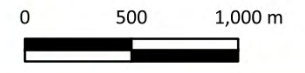

Calvale to Calliope TL Surface Water Impact Assessment

10% AEP 2090-SSP3 Results
Page 7/18



J:\2254-04_C2C-PEP_GISA\Amendments\3_GIS\GIS\2254-04-Alignment_Mapping.qgz (Figure_Alignment_Depth_10p_CC) (Exported: 06 March 2026)
Projection: EPSG:7856

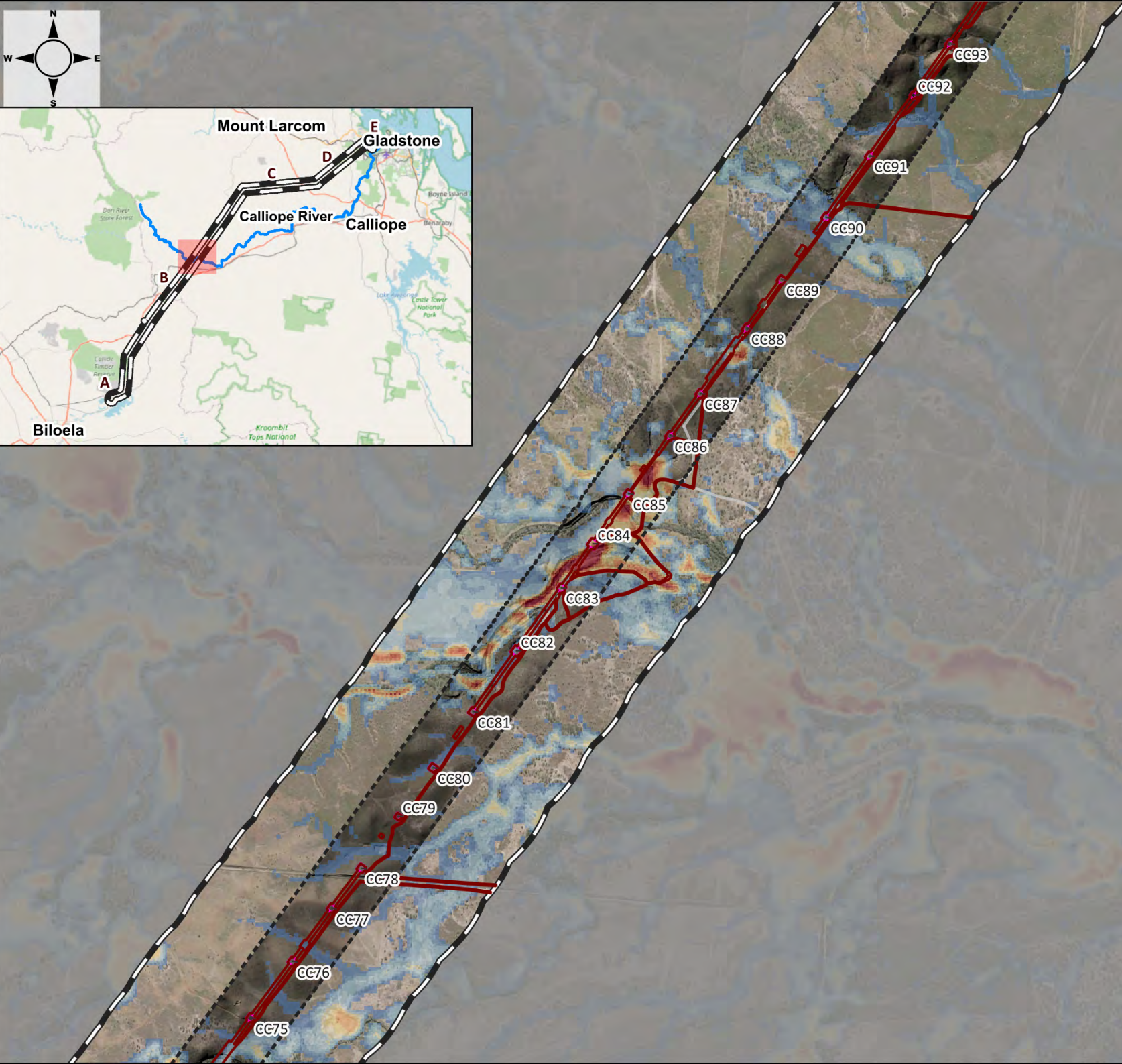

- Legend**
- Project Area
 - Towers
 - 1 m LiDAR Extent
 - Disturbance Footprint
 - Indicative Access Tracks

- Flood depth (m)**
- up to 0.25 m
 - 0.25 to 0.5 m
 - 0.5 to 1.0 m
 - 1.0 to 1.5 m
 - 1.5 to 2.0 m
 - 2.0 to 2.5 m
 - 2.5 to 3.0 m
 - 3.0 to 3.5 m
 - 3.5 to 4.0 m
 - 4.0 to 4.5 m
 - > 4.5 m

Modelling results are based on the best available elevation resolution: Copernicus. The available LiDAR data indicates areas where the elevation and therefore hydraulic model are inconsistent with local survey. All model results should be considered indicative and subject to broader survey validation.

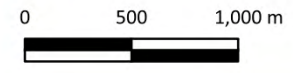

Calvale to Calliope TL Surface Water Impact Assessment

10% AEP 2090-SSP3 Results
Page 8/18



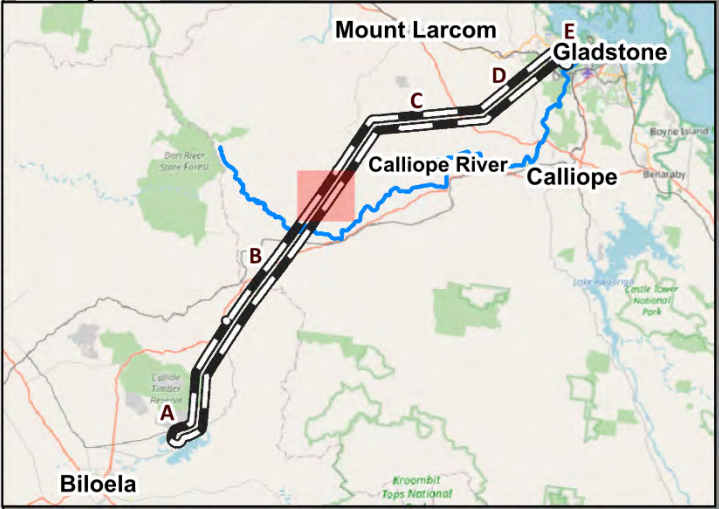

- Legend**
- Project Area
 - Towers
 - 1 m LiDAR Extent
 - Disturbance Footprint
 - Indicative Access Tracks

- Flood depth (m)**
- up to 0.25 m
 - 0.25 to 0.5 m
 - 0.5 to 1.0 m
 - 1.0 to 1.5 m
 - 1.5 to 2.0 m
 - 2.0 to 2.5 m
 - 2.5 to 3.0 m
 - 3.0 to 3.5 m
 - 3.5 to 4.0 m
 - 4.0 to 4.5 m
 - > 4.5 m

Modelling results are based on the best available elevation resolution: Copernicus. The available LiDAR data indicates areas where the elevation and therefore hydraulic model are inconsistent with local survey. All model results should be considered indicative and subject to broader survey validation.



**Calvale to Calliope TL
Surface Water
Impact Assessment**

10% AEP 2090-SSP3 Results
Page 9/18



J:\2254-04_C2C-PEP_GISAmendments\3_GIS\GIS\2254-04-Alignment_Mapping.qgz (Figure_Alignment_Depth_10p_CC) (Exported: 06 March 2026)
Projection: EPSG:7856

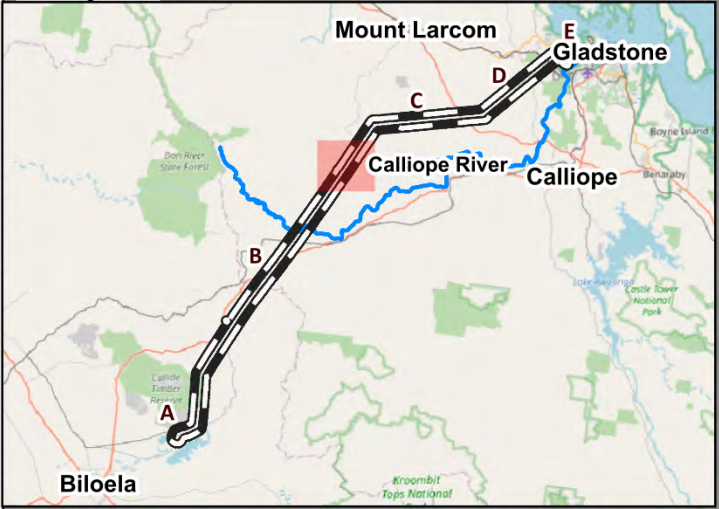

- Legend**
- Project Area
 - Towers
 - 1 m LiDAR Extent
 - Disturbance Footprint
 - Indicative Access Tracks

- Flood depth (m)**
- up to 0.25 m
 - 0.25 to 0.5 m
 - 0.5 to 1.0 m
 - 1.0 to 1.5 m
 - 1.5 to 2.0 m
 - 2.0 to 2.5 m
 - 2.5 to 3.0 m
 - 3.0 to 3.5 m
 - 3.5 to 4.0 m
 - 4.0 to 4.5 m
 - > 4.5 m

Modelling results are based on the best available elevation resolution: Copernicus. The available LiDAR data indicates areas where the elevation and therefore hydraulic model are inconsistent with local survey. All model results should be considered indicative and subject to broader survey validation.



Calvale to Calliope TL Surface Water Impact Assessment

10% AEP 2090-SSP3 Results
Page 10/18



J:\2254-04_C2C-PEP_GISAmendments\3_GIS\GIS\2254-04-Alignment_Mapping.qgz (Figure_Alignment_Depth_10p_CC) (Exported: 06 March 2026)
Projection: EPSG:7856

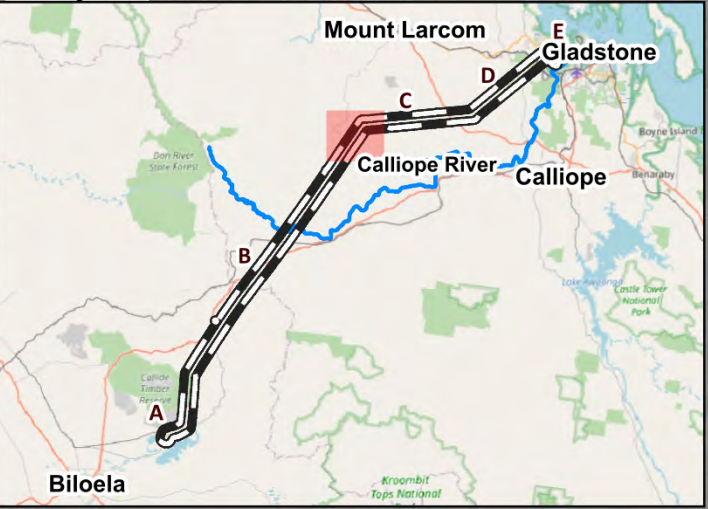

- Legend
- Project Area
 - Towers
 - 1 m LiDAR Extent
 - Disturbance Footprint
 - Indicative Access Tracks

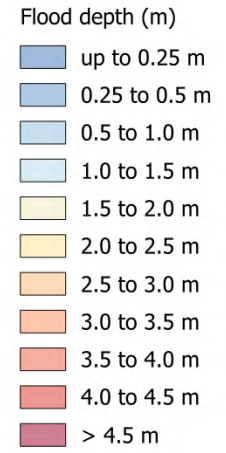

Modelling results are based on the best available elevation resolution: Copernicus. The available LiDAR data indicates areas where the elevation and therefore hydraulic model are inconsistent with local survey. All model results should be considered indicative and subject to broader survey validation.



Calvale to Calliope TL Surface Water Impact Assessment

10% AEP 2090-SSP3 Results
Page 11/18

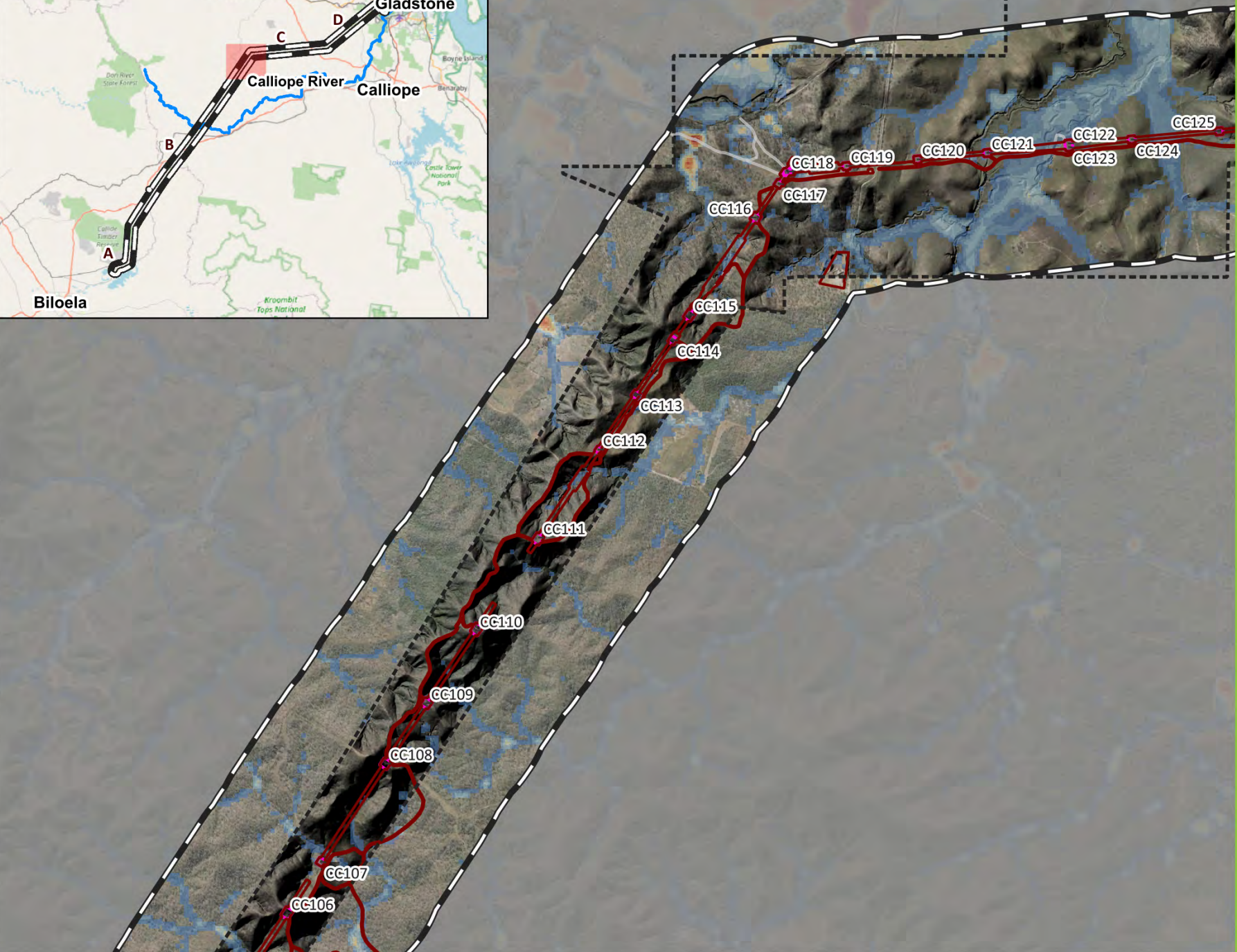

J:\2254-04_C2C-PEP_GISAmendments\3_GIS\OGIS\2254-04-Alignment_Mapping.qgz (Figure_Alignment_Depth_10p_CC) (Exported: 06 March 2026)
Projection: EPSG:7856

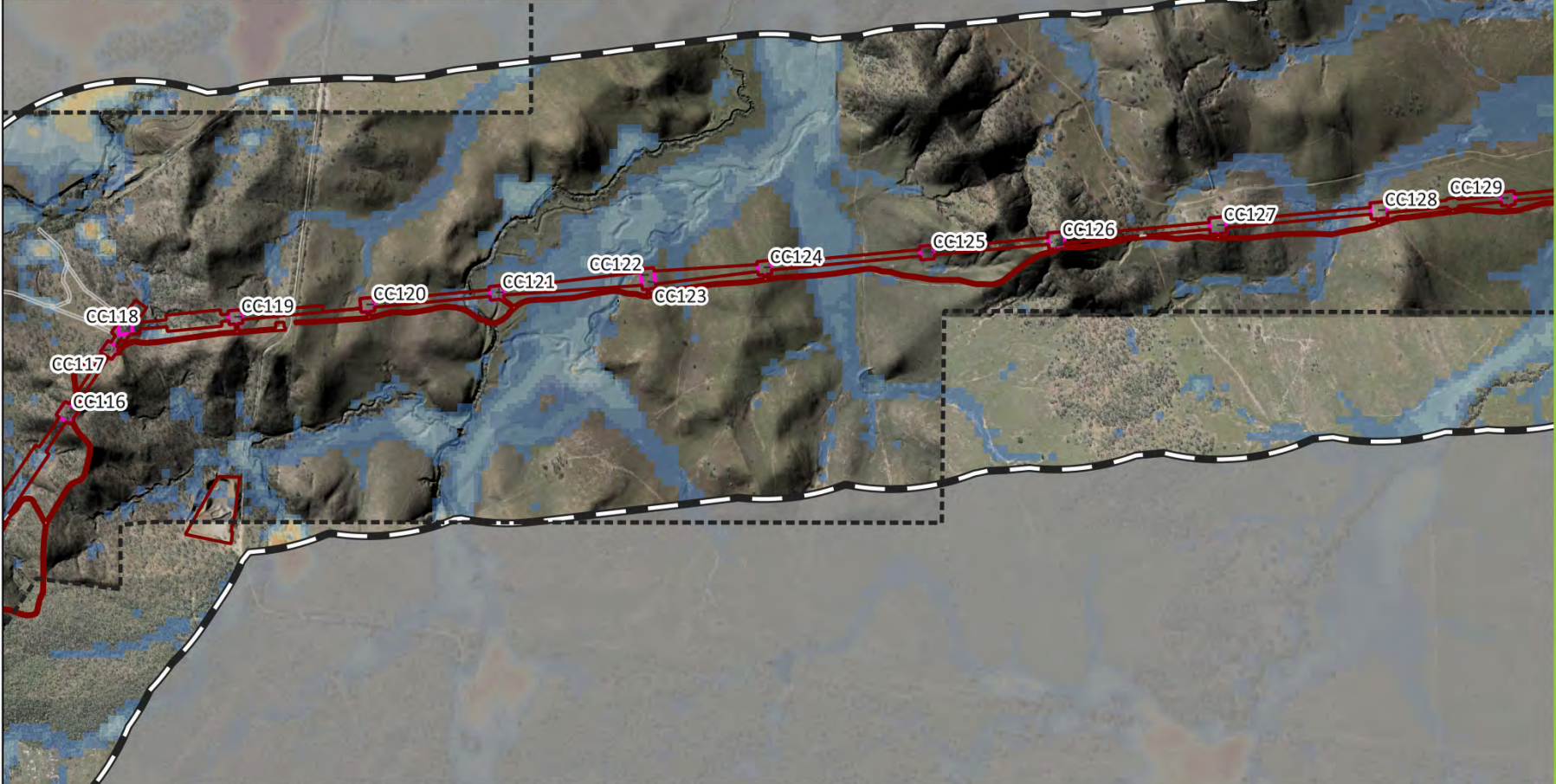
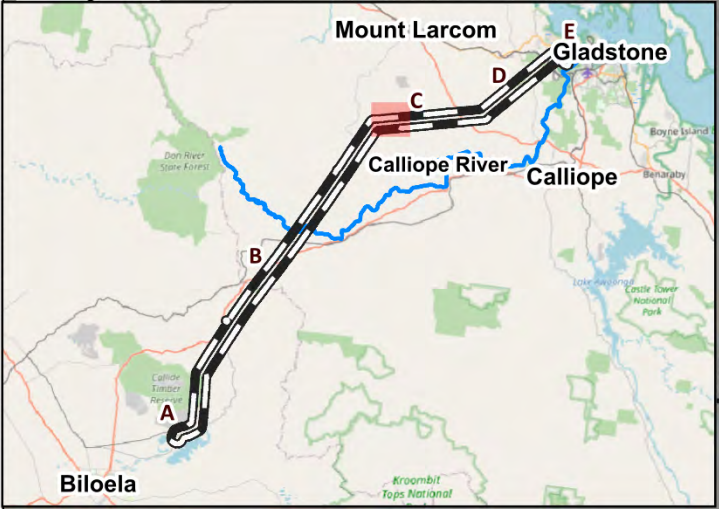

- Legend**
- Project Area
 - Towers
 - 1 m LiDAR Extent
 - Disturbance Footprint
 - Indicative Access Tracks

- Flood depth (m)**
- up to 0.25 m
 - 0.25 to 0.5 m
 - 0.5 to 1.0 m
 - 1.0 to 1.5 m
 - 1.5 to 2.0 m
 - 2.0 to 2.5 m
 - 2.5 to 3.0 m
 - 3.0 to 3.5 m
 - 3.5 to 4.0 m
 - 4.0 to 4.5 m
 - > 4.5 m

Modelling results are based on the best available elevation resolution: Copernicus. The available LiDAR data indicates areas where the elevation and therefore hydraulic model are inconsistent with local survey. All model results should be considered indicative and subject to broader survey validation.



**Calvale to Calliope TL
Surface Water
Impact Assessment**

10% AEP 2090-SSP3 Results
Page 12/18



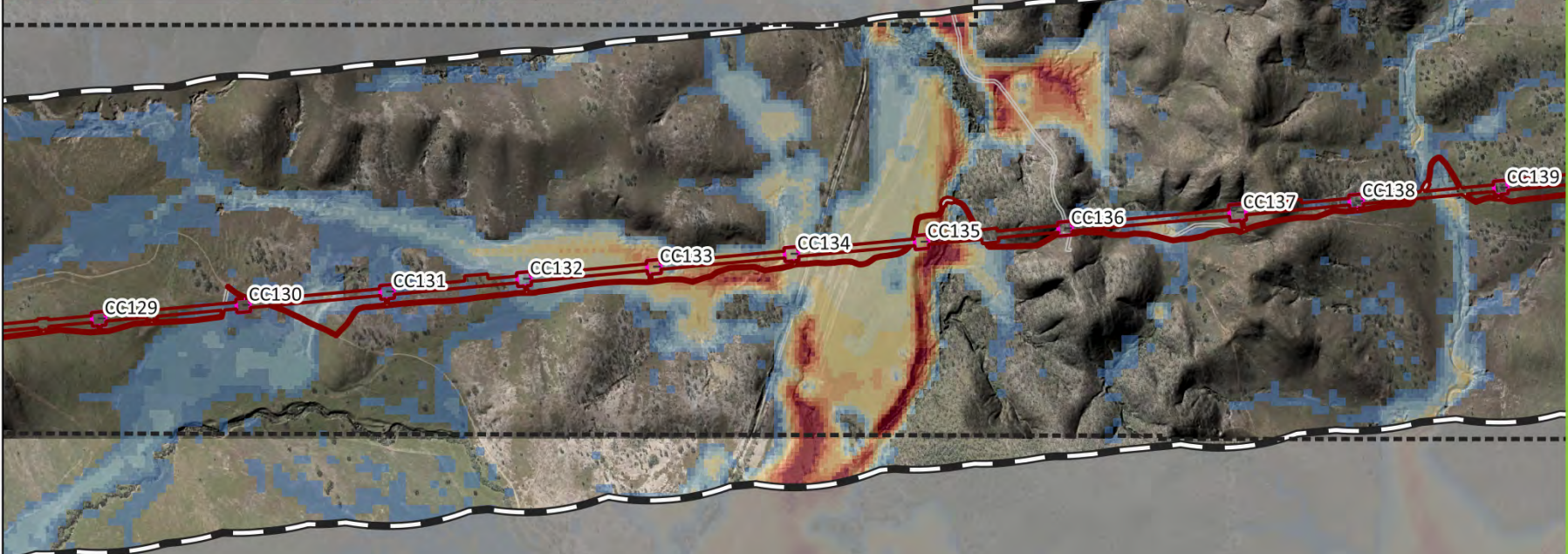
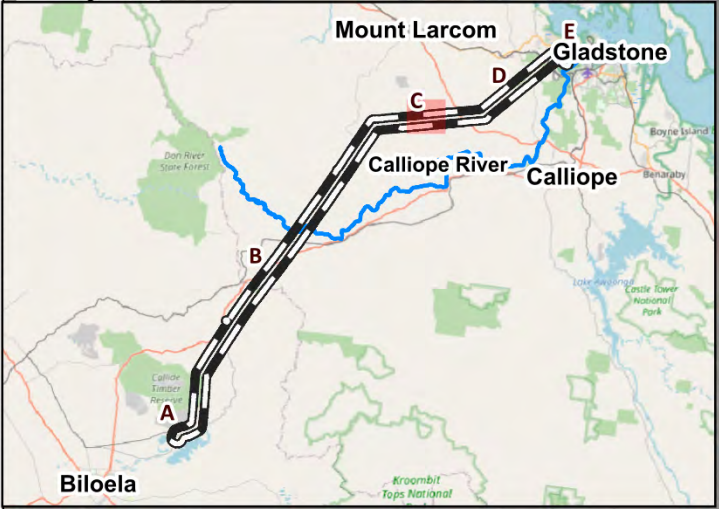

- Legend**
- Project Area
 - Towers
 - 1 m LiDAR Extent
 - Disturbance Footprint
 - Indicative Access Tracks

- Flood depth (m)**
- up to 0.25 m
 - 0.25 to 0.5 m
 - 0.5 to 1.0 m
 - 1.0 to 1.5 m
 - 1.5 to 2.0 m
 - 2.0 to 2.5 m
 - 2.5 to 3.0 m
 - 3.0 to 3.5 m
 - 3.5 to 4.0 m
 - 4.0 to 4.5 m
 - > 4.5 m

Modelling results are based on the best available elevation resolution: Copernicus. The available LiDAR data indicates areas where the elevation and therefore hydraulic model are inconsistent with local survey. All model results should be considered indicative and subject to broader survey validation.



**Calvale to Calliope TL
Surface Water
Impact Assessment**

10% AEP 2090-SSP3 Results
Page 13/18



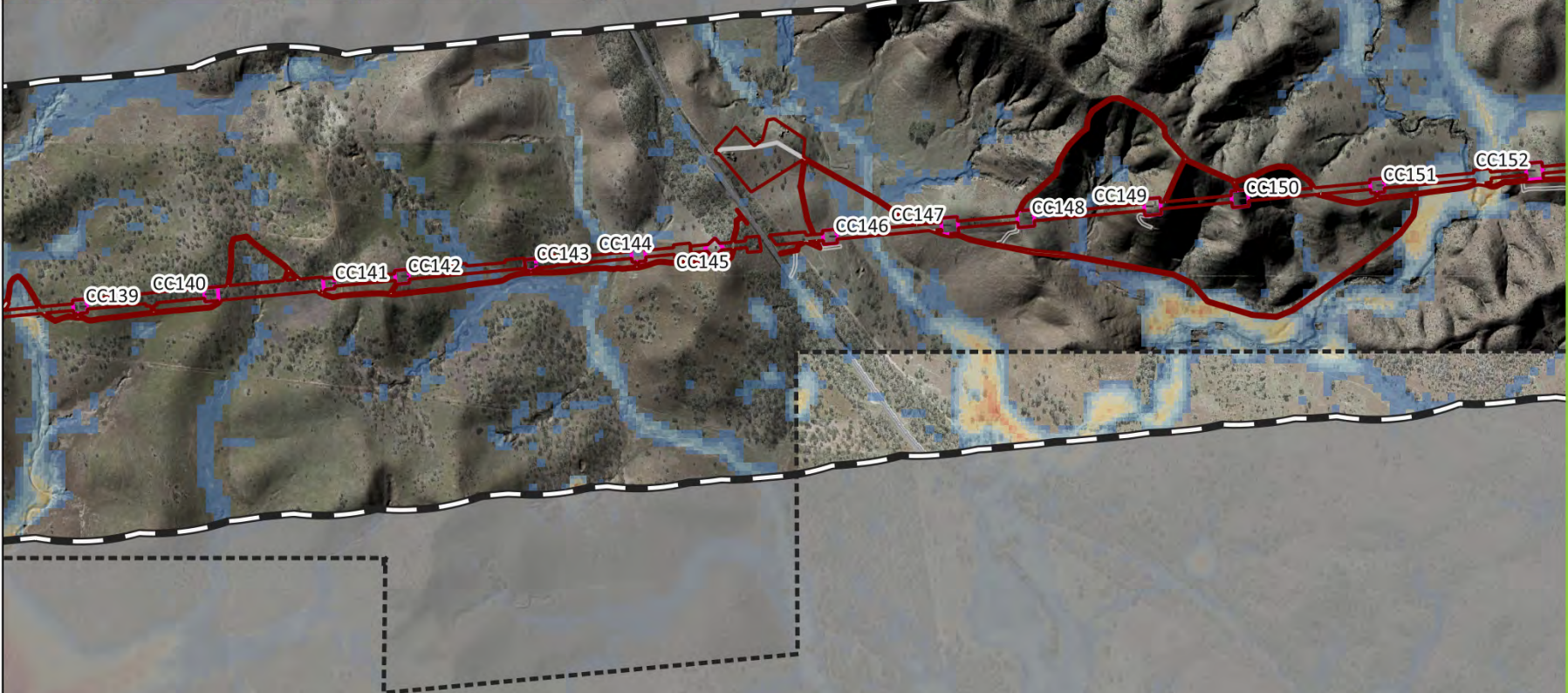
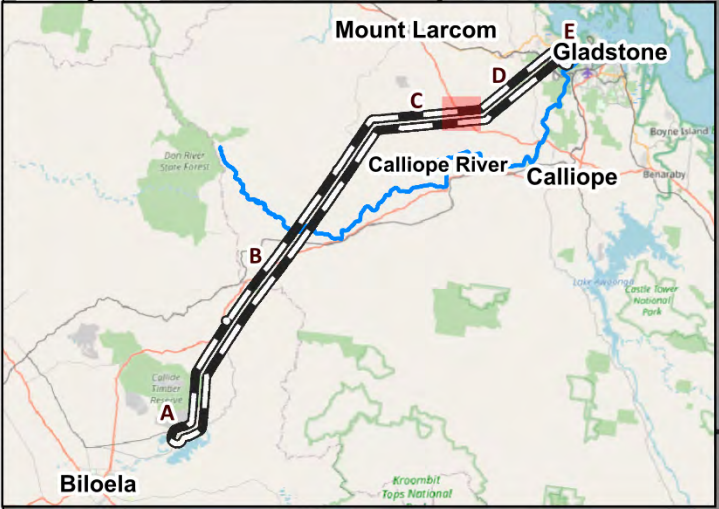

- Legend**
- Project Area
 - Towers
 - 1 m LiDAR Extent
 - Disturbance Footprint
 - Indicative Access Tracks

- Flood depth (m)**
- up to 0.25 m
 - 0.25 to 0.5 m
 - 0.5 to 1.0 m
 - 1.0 to 1.5 m
 - 1.5 to 2.0 m
 - 2.0 to 2.5 m
 - 2.5 to 3.0 m
 - 3.0 to 3.5 m
 - 3.5 to 4.0 m
 - 4.0 to 4.5 m
 - > 4.5 m

Modelling results are based on the best available elevation resolution: Copernicus. The available LiDAR data indicates areas where the elevation and therefore hydraulic model are inconsistent with local survey. All model results should be considered indicative and subject to broader survey validation.

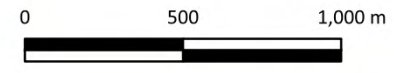

**Calvale to Calliope TL
Surface Water
Impact Assessment**

10% AEP 2090-SSP3 Results
Page 14/18



J:\2254-04_C2C-PEP_GISAmendments\3_GIS\GIS2254-04-Alignment_Mapping.qgz (Figure_Alignment_Depth_10p_CC) (Exported: 06 March 2026)
Projection: EPSG:7856

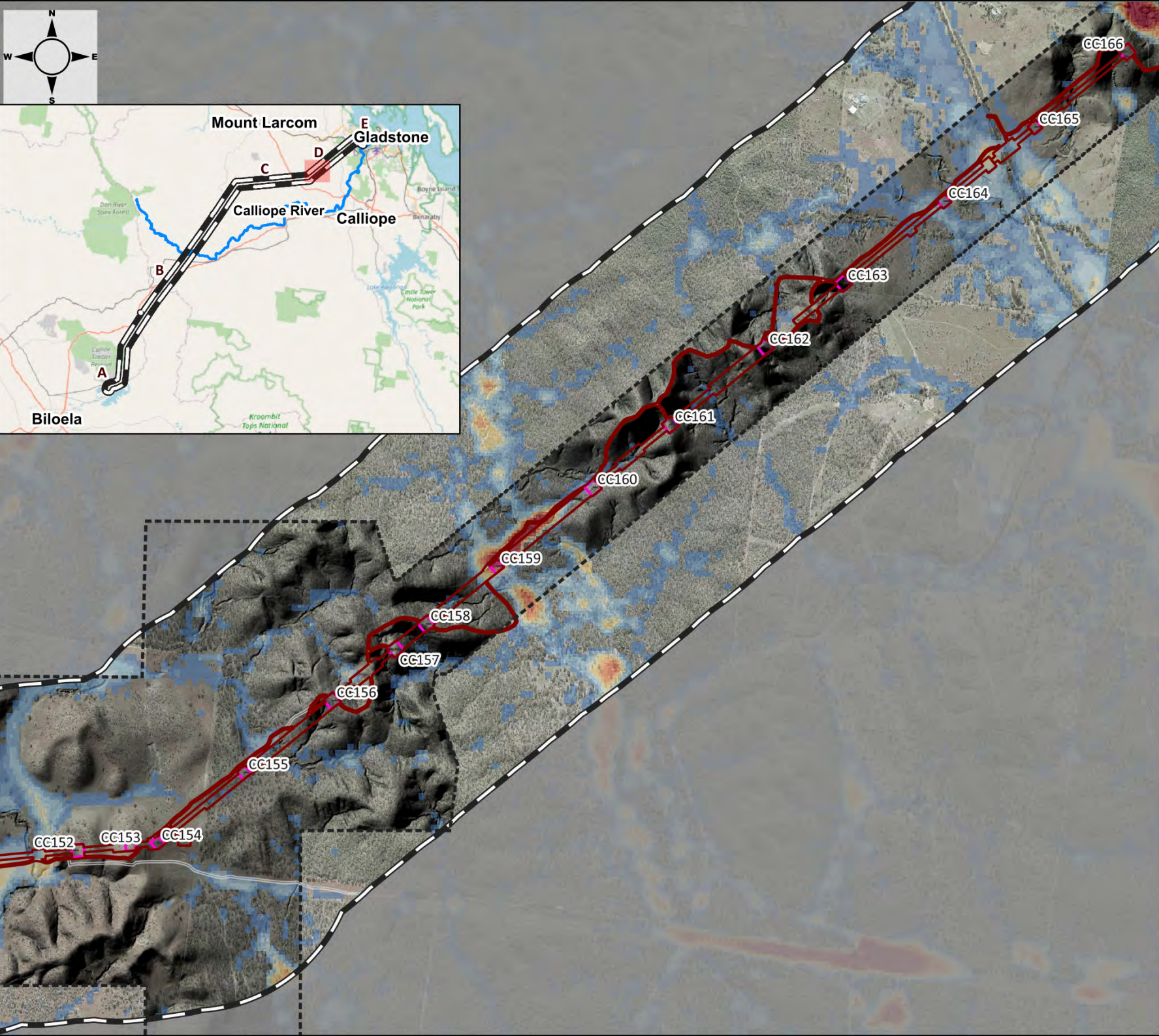
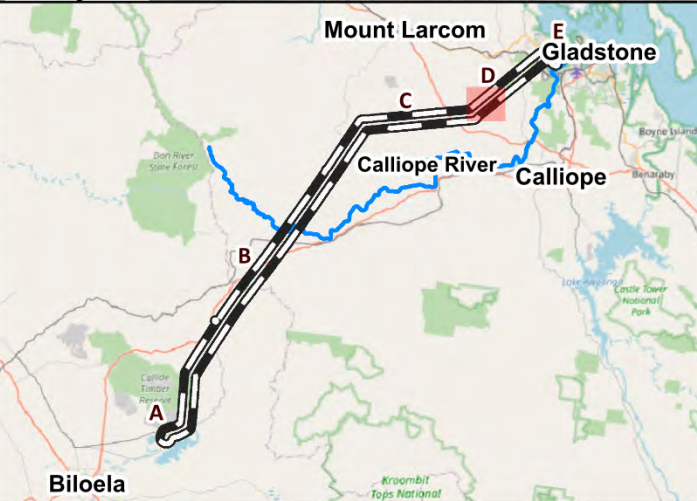

- Legend**
- Project Area
 - Towers
 - 1 m LiDAR Extent
 - Disturbance Footprint
 - Indicative Access Tracks

- Flood depth (m)**
- up to 0.25 m
 - 0.25 to 0.5 m
 - 0.5 to 1.0 m
 - 1.0 to 1.5 m
 - 1.5 to 2.0 m
 - 2.0 to 2.5 m
 - 2.5 to 3.0 m
 - 3.0 to 3.5 m
 - 3.5 to 4.0 m
 - 4.0 to 4.5 m
 - > 4.5 m

Modelling results are based on the best available elevation resolution: Copernicus. The available LiDAR data indicates areas where the elevation and therefore hydraulic model are inconsistent with local survey. All model results should be considered indicative and subject to broader survey validation.



Calvale to Calliope TL Surface Water Impact Assessment

10% AEP 2090-SSP3 Results
Page 15/18



J:\2254-04_C2C-PEP_GISAmendments\3_GIS\GIS\2254-04-Alignment_Mapping.qgz (Figure_Alignment_Depth_10p_CC) (Exported: 06 March 2026)
Projection: EPSG:7856

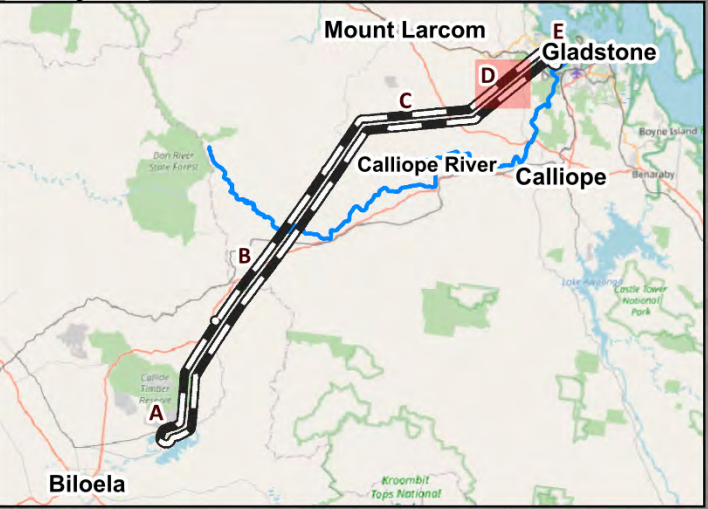

- Legend
- Project Area
 - Towers
 - 1 m LiDAR Extent
 - Disturbance Footprint
 - Indicative Access Tracks

- Flood depth (m)
- up to 0.25 m
 - 0.25 to 0.5 m
 - 0.5 to 1.0 m
 - 1.0 to 1.5 m
 - 1.5 to 2.0 m
 - 2.0 to 2.5 m
 - 2.5 to 3.0 m
 - 3.0 to 3.5 m
 - 3.5 to 4.0 m
 - 4.0 to 4.5 m
 - > 4.5 m

Modelling results are based on the best available elevation resolution: Copernicus. The available LiDAR data indicates areas where the elevation and therefore hydraulic model are inconsistent with local survey. All model results should be considered indicative and subject to broader survey validation.

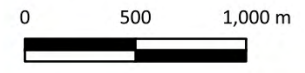

Calvale to Calliope TL Surface Water Impact Assessment

10% AEP 2090-SSP3 Results
Page 16/18



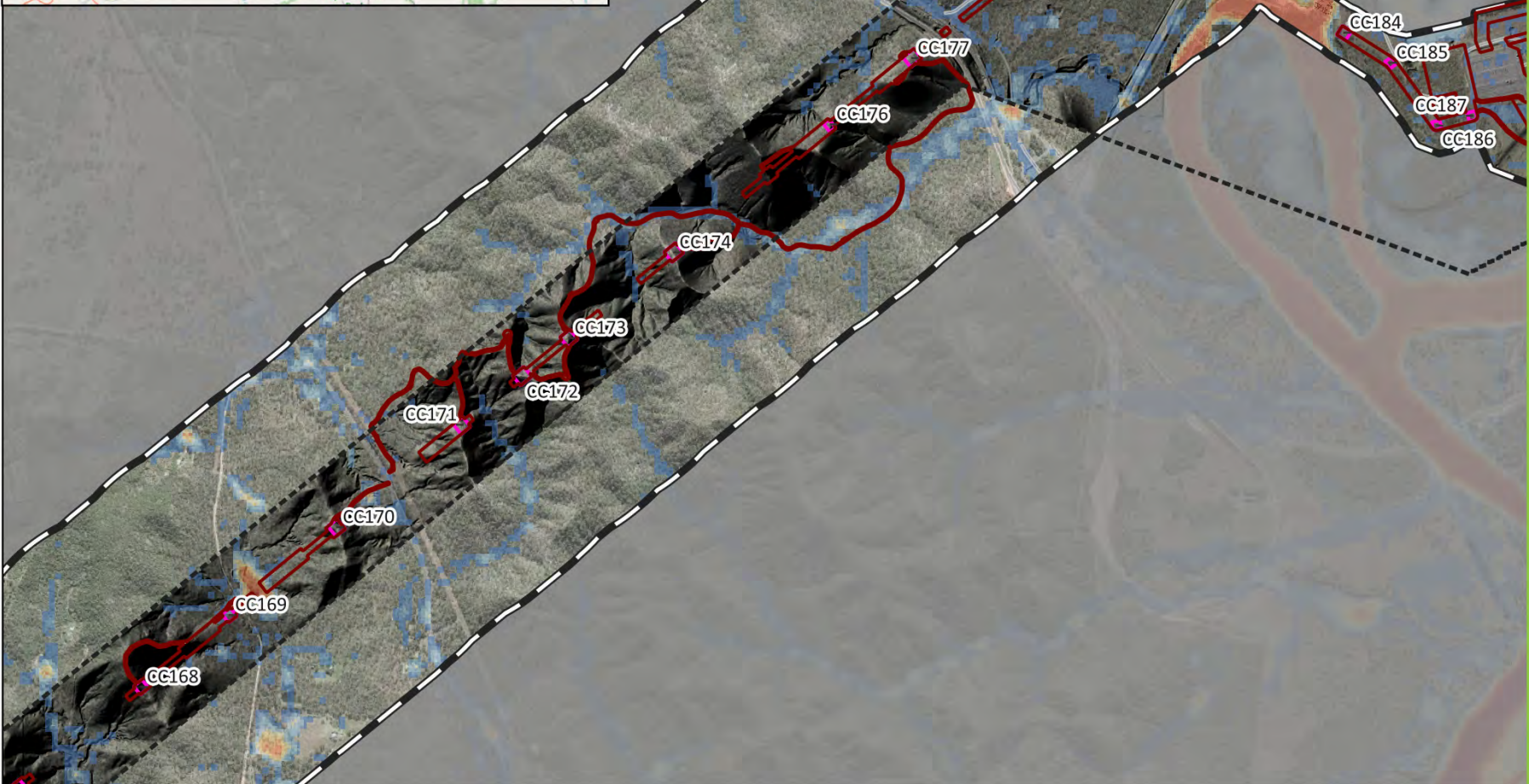

- Legend
- Project Area
 - Towers
 - 1 m LiDAR Extent
 - Disturbance Footprint
 - Indicative Access Tracks

- Flood depth (m)
- up to 0.25 m
 - 0.25 to 0.5 m
 - 0.5 to 1.0 m
 - 1.0 to 1.5 m
 - 1.5 to 2.0 m
 - 2.0 to 2.5 m
 - 2.5 to 3.0 m
 - 3.0 to 3.5 m
 - 3.5 to 4.0 m
 - 4.0 to 4.5 m
 - > 4.5 m

Modelling results are based on the best available elevation resolution: Copernicus. The available LiDAR data indicates areas where the elevation and therefore hydraulic model are inconsistent with local survey. All model results should be considered indicative and subject to broader survey validation.

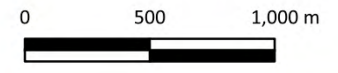

Calvale to Calliope TL Surface Water Impact Assessment

10% AEP 2090-SSP3 Results
Page 17/18



J:\2254-04_C2C-PEP_GISAmendments\3_GIS\QGIS\2254-04-Alignment_Mapping.qgz (Figure_Alignment_Depth_10p_CC) (Exported: 06 March 2026)
Projection: EPSG:7856

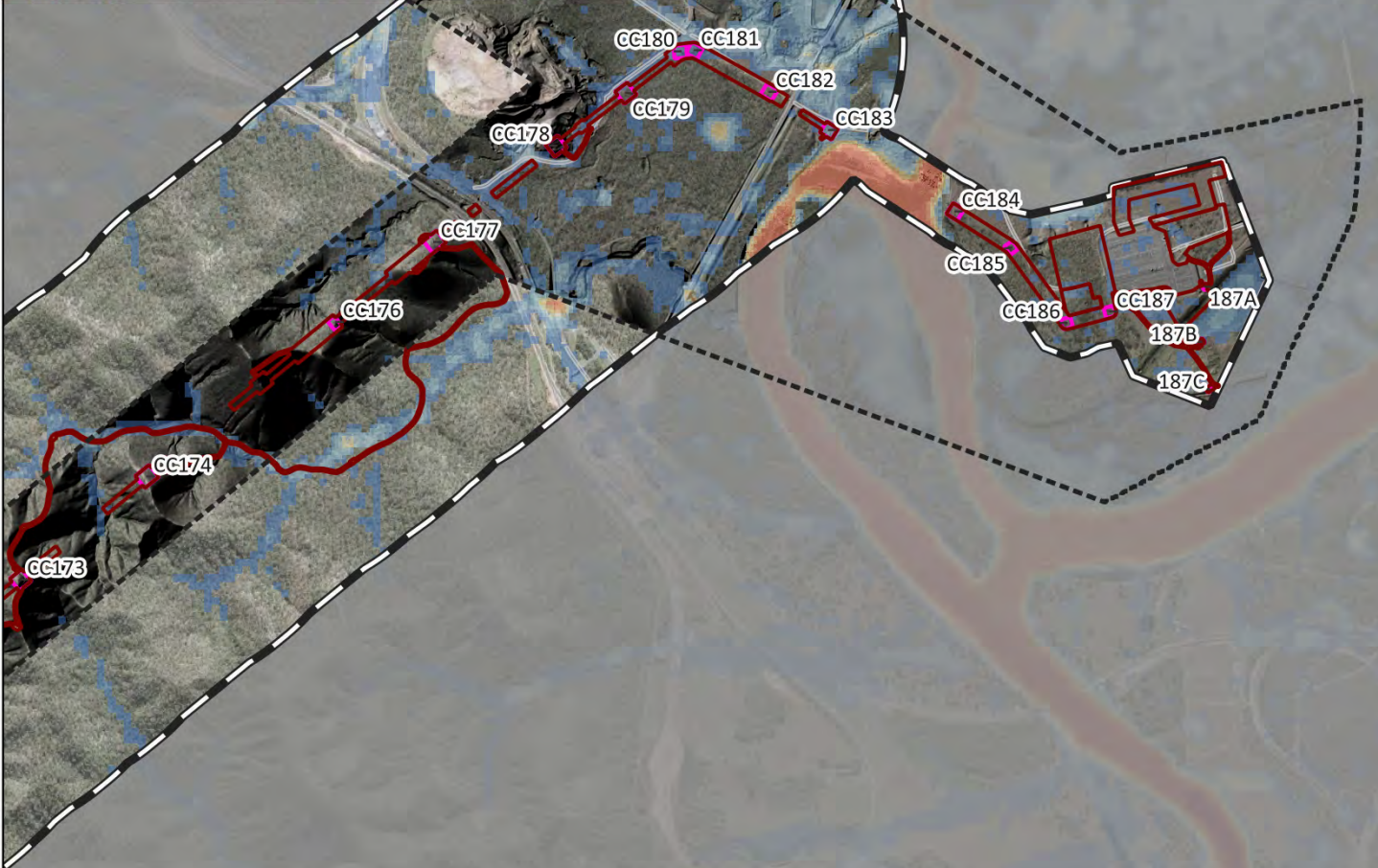

- Legend**
- Project Area
 - Towers
 - 1 m LiDAR Extent
 - Disturbance Footprint
 - Indicative Access Tracks

- Flood depth (m)**
- up to 0.25 m
 - 0.25 to 0.5 m
 - 0.5 to 1.0 m
 - 1.0 to 1.5 m
 - 1.5 to 2.0 m
 - 2.0 to 2.5 m
 - 2.5 to 3.0 m
 - 3.0 to 3.5 m
 - 3.5 to 4.0 m
 - 4.0 to 4.5 m
 - > 4.5 m

Modelling results are based on the best available elevation resolution: Copernicus. The available LiDAR data indicates areas where the elevation and therefore hydraulic model are inconsistent with local survey. All model results should be considered indicative and subject to broader survey validation.



Calvale to Calliope TL Surface Water Impact Assessment

10% AEP 2090-SSP3 Results
Page 18/18



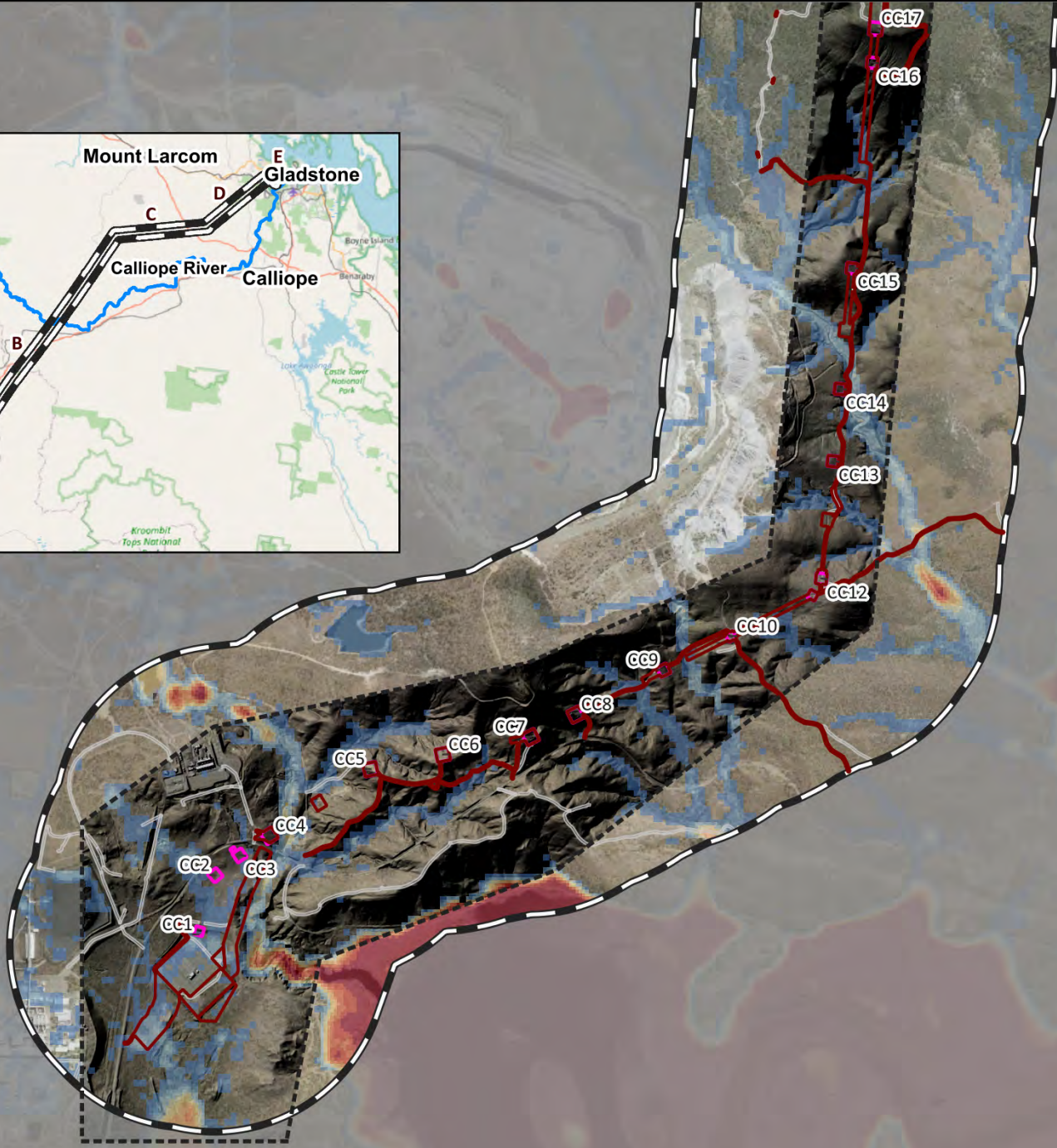

- Legend**
- Project Area
 - Towers
 - 1 m LiDAR Extent
 - Disturbance Footprint
 - Indicative Access Tracks

- Flood depth (m)**
- up to 0.25 m
 - 0.25 to 0.5 m
 - 0.5 to 1.0 m
 - 1.0 to 1.5 m
 - 1.5 to 2.0 m
 - 2.0 to 2.5 m
 - 2.5 to 3.0 m
 - 3.0 to 3.5 m
 - 3.5 to 4.0 m
 - 4.0 to 4.5 m
 - > 4.5 m

Modelling results are based on the best available elevation resolution: Copernicus. The available LiDAR data indicates areas where the elevation and therefore hydraulic model are inconsistent with local survey. All model results should be considered indicative and subject to broader survey validation.

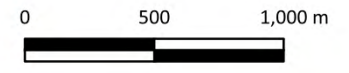

**Calvale to Calliope TL
Surface Water
Impact Assessment**

0.2% (1in500) AEP 2090-SSP3
Results
Page 1/18



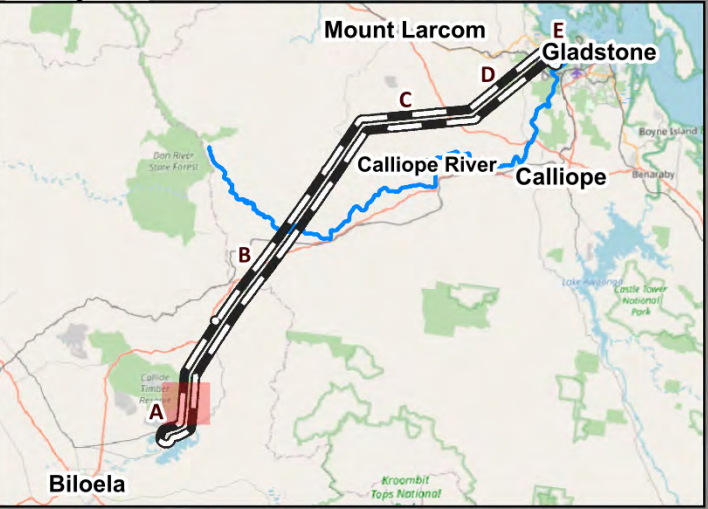

- Legend**
- Project Area
 - Towers
 - 1 m LiDAR Extent
 - Disturbance Footprint
 - Indicative Access Tracks

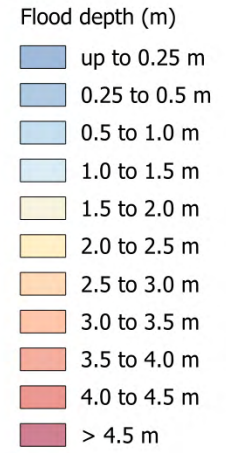

Modelling results are based on the best available elevation resolution: Copernicus. The available LiDAR data indicates areas where the elevation and therefore hydraulic model are inconsistent with local survey. All model results should be considered indicative and subject to broader survey validation.

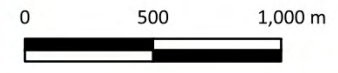

**Calvale to Calliope TL
Surface Water
Impact Assessment**

0.2% (1in500) AEP 2090-SSP3
Results
Page 2/18





- Legend**
- Project Area
 - Towers
 - 1 m LiDAR Extent
 - Disturbance Footprint
 - Indicative Access Tracks

- Flood depth (m)**
- up to 0.25 m
 - 0.25 to 0.5 m
 - 0.5 to 1.0 m
 - 1.0 to 1.5 m
 - 1.5 to 2.0 m
 - 2.0 to 2.5 m
 - 2.5 to 3.0 m
 - 3.0 to 3.5 m
 - 3.5 to 4.0 m
 - 4.0 to 4.5 m
 - > 4.5 m

Modelling results are based on the best available elevation resolution: Copernicus. The available LiDAR data indicates areas where the elevation and therefore hydraulic model are inconsistent with local survey. All model results should be considered indicative and subject to broader survey validation.

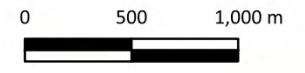

**Calvale to Calliope TL
Surface Water
Impact Assessment**

0.2% (1in500) AEP 2090-SSP3
Results
Page 3/18



WATER + ENVIRONMENT

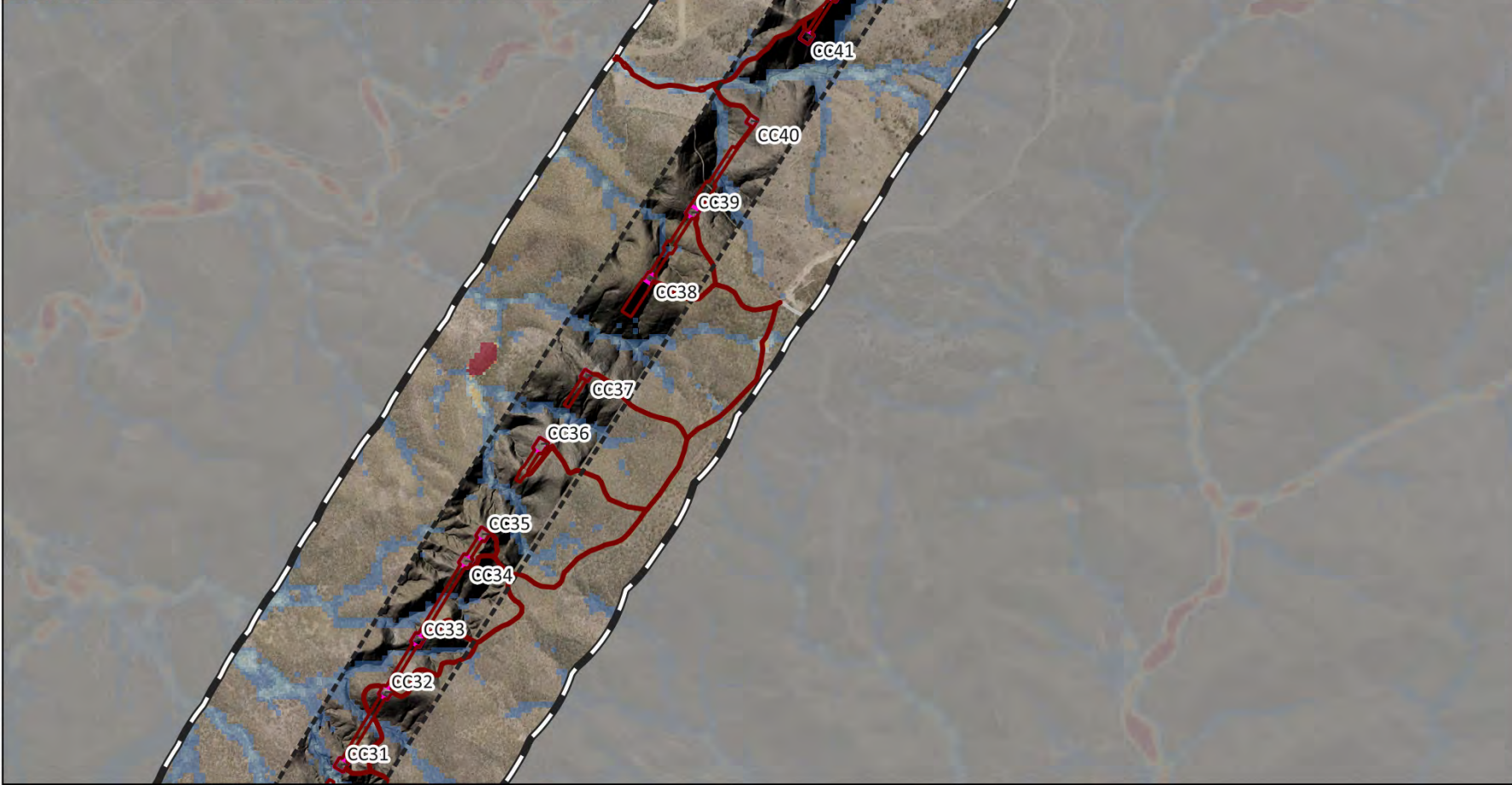

- Legend**
- Project Area
 - Towers
 - 1 m LiDAR Extent
 - Disturbance Footprint
 - Indicative Access Tracks

- Flood depth (m)**
- up to 0.25 m
 - 0.25 to 0.5 m
 - 0.5 to 1.0 m
 - 1.0 to 1.5 m
 - 1.5 to 2.0 m
 - 2.0 to 2.5 m
 - 2.5 to 3.0 m
 - 3.0 to 3.5 m
 - 3.5 to 4.0 m
 - 4.0 to 4.5 m
 - > 4.5 m

Modelling results are based on the best available elevation resolution: Copernicus. The available LiDAR data indicates areas where the elevation and therefore hydraulic model are inconsistent with local survey. All model results should be considered indicative and subject to broader survey validation.



**Calvale to Calliope TL
Surface Water
Impact Assessment**

0.2% (1in500) AEP 2090-SSP3
Results
Page 4/18



WATER + ENVIRONMENT

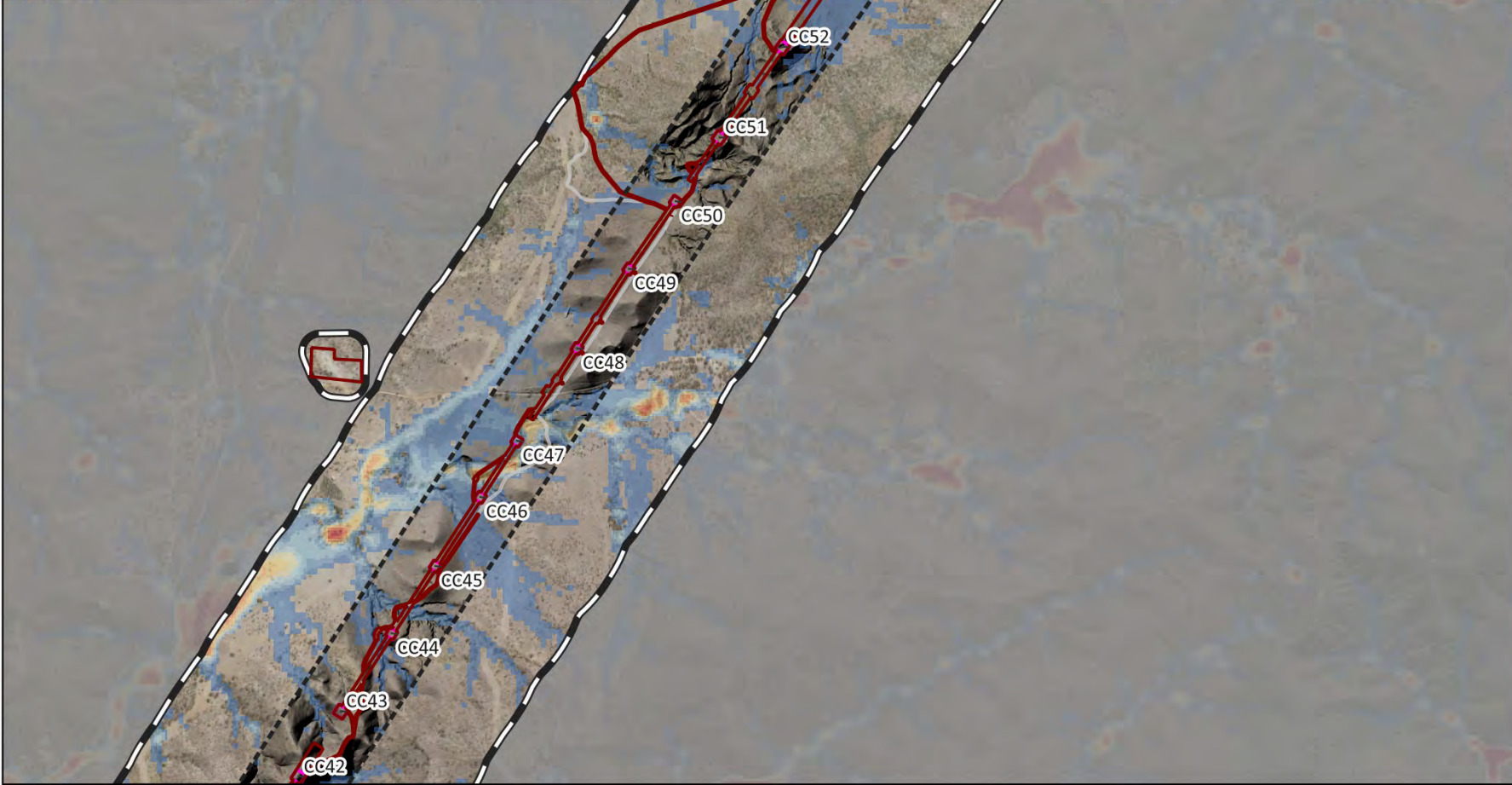

- Legend**
- Project Area
 - Towers
 - 1 m LiDAR Extent
 - Disturbance Footprint
 - Indicative Access Tracks

- Flood depth (m)**
- up to 0.25 m
 - 0.25 to 0.5 m
 - 0.5 to 1.0 m
 - 1.0 to 1.5 m
 - 1.5 to 2.0 m
 - 2.0 to 2.5 m
 - 2.5 to 3.0 m
 - 3.0 to 3.5 m
 - 3.5 to 4.0 m
 - 4.0 to 4.5 m
 - > 4.5 m

Modelling results are based on the best available elevation resolution: Copernicus. The available LiDAR data indicates areas where the elevation and therefore hydraulic model are inconsistent with local survey. All model results should be considered indicative and subject to broader survey validation.



**Calvale to Calliope TL
Surface Water
Impact Assessment**

0.2% (1in500) AEP 2090-SSP3
Results
Page 5/18



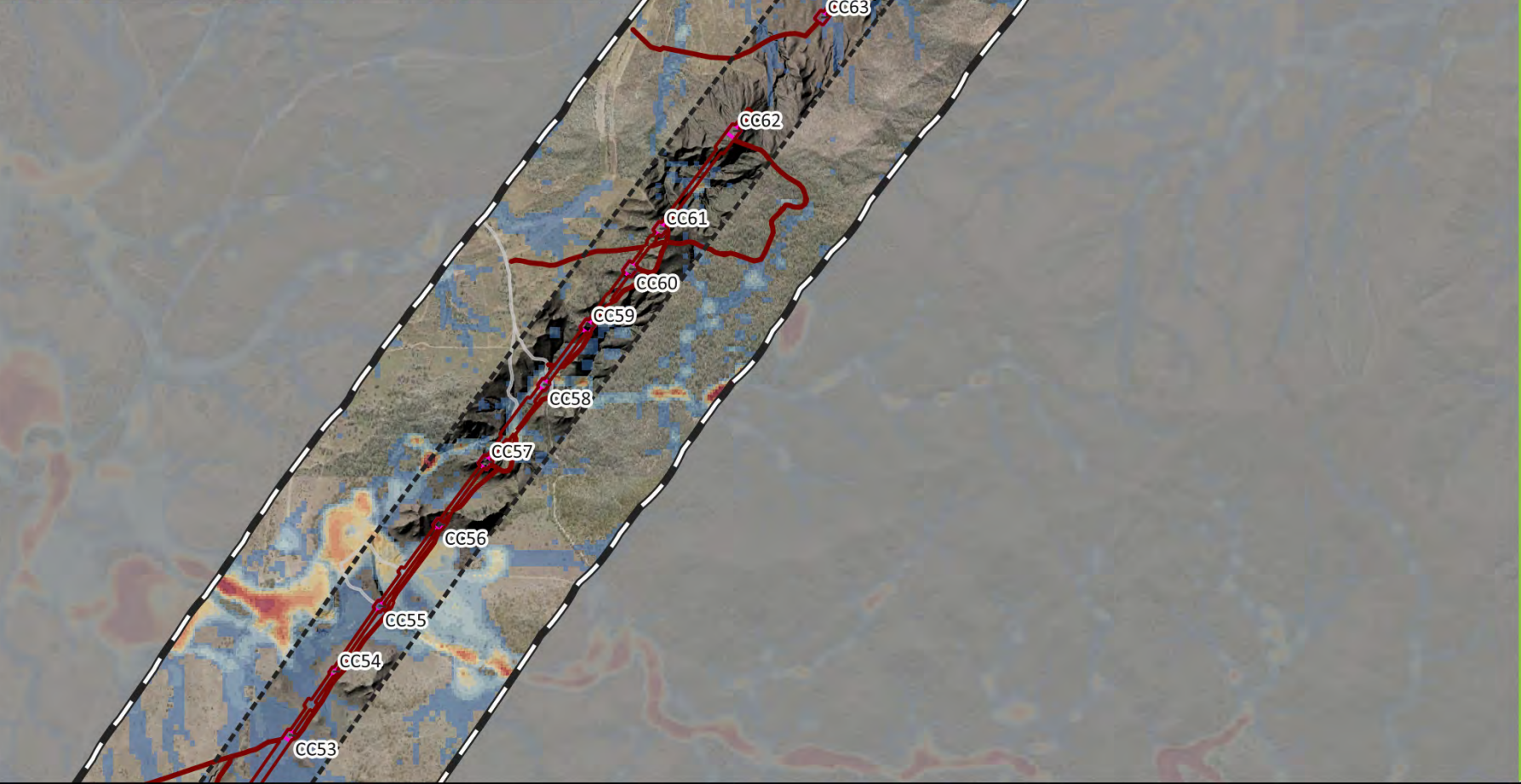

- Legend**
- Project Area
 - Towers
 - 1 m LiDAR Extent
 - Disturbance Footprint
 - Indicative Access Tracks

- Flood depth (m)**
- up to 0.25 m
 - 0.25 to 0.5 m
 - 0.5 to 1.0 m
 - 1.0 to 1.5 m
 - 1.5 to 2.0 m
 - 2.0 to 2.5 m
 - 2.5 to 3.0 m
 - 3.0 to 3.5 m
 - 3.5 to 4.0 m
 - 4.0 to 4.5 m
 - > 4.5 m

Modelling results are based on the best available elevation resolution: Copernicus. The available LiDAR data indicates areas where the elevation and therefore hydraulic model are inconsistent with local survey. All model results should be considered indicative and subject to broader survey validation.



**Calvale to Calliope TL
Surface Water
Impact Assessment**

0.2% (1in500) AEP 2090-SSP3
Results
Page 6/18



WATER + ENVIRONMENT

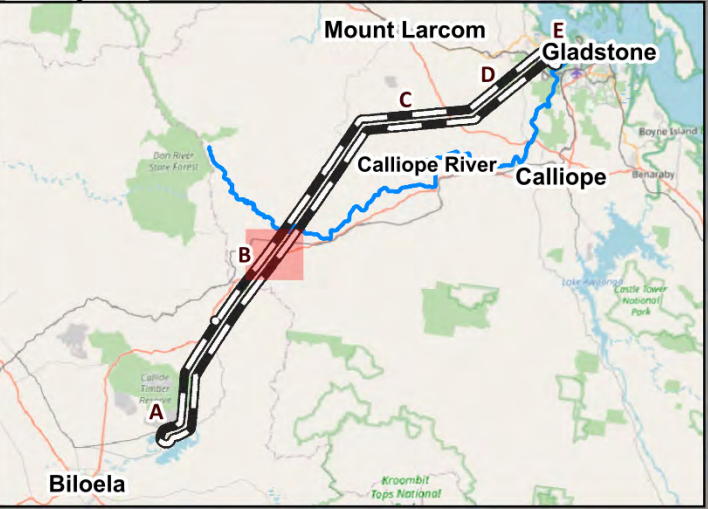
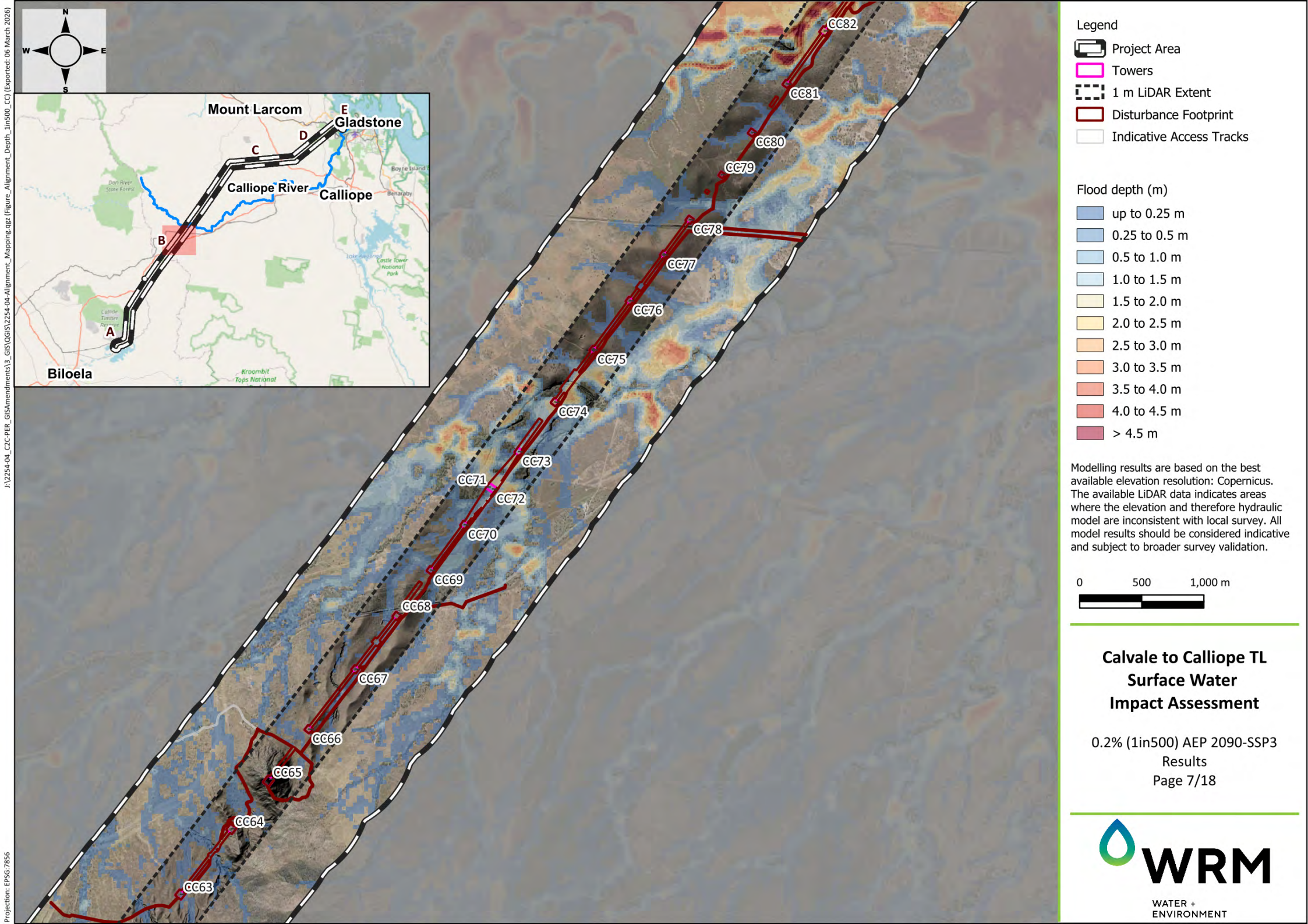

- Legend**
- Project Area
 - Towers
 - 1 m LiDAR Extent
 - Disturbance Footprint
 - Indicative Access Tracks

- Flood depth (m)**
- up to 0.25 m
 - 0.25 to 0.5 m
 - 0.5 to 1.0 m
 - 1.0 to 1.5 m
 - 1.5 to 2.0 m
 - 2.0 to 2.5 m
 - 2.5 to 3.0 m
 - 3.0 to 3.5 m
 - 3.5 to 4.0 m
 - 4.0 to 4.5 m
 - > 4.5 m

Modelling results are based on the best available elevation resolution: Copernicus. The available LiDAR data indicates areas where the elevation and therefore hydraulic model are inconsistent with local survey. All model results should be considered indicative and subject to broader survey validation.

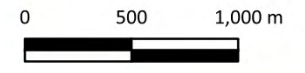

**Calvale to Calliope TL
Surface Water
Impact Assessment**

0.2% (1in500) AEP 2090-SSP3
Results
Page 7/18

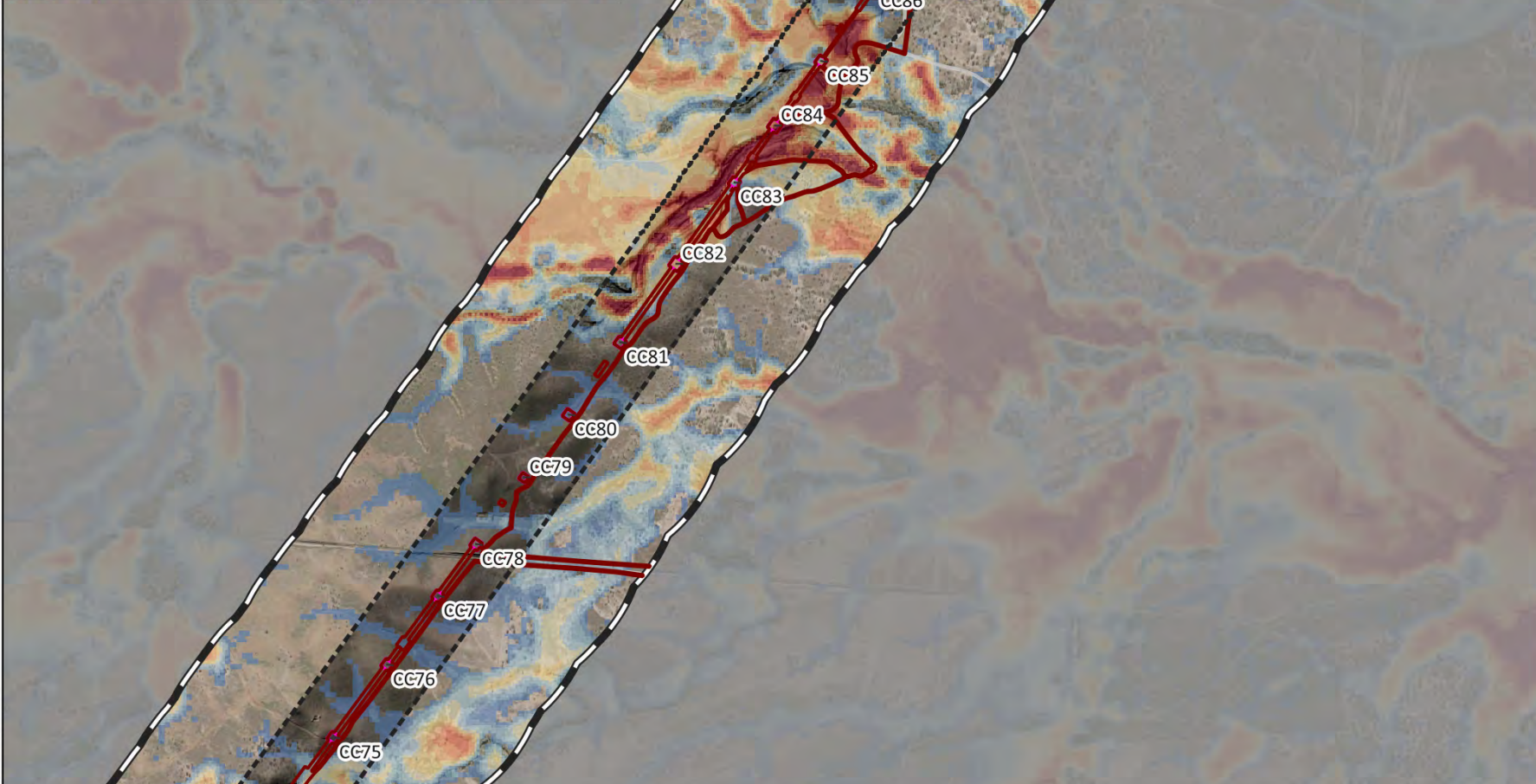

- Legend**
- Project Area
 - Towers
 - 1 m LiDAR Extent
 - Disturbance Footprint
 - Indicative Access Tracks

- Flood depth (m)**
- up to 0.25 m
 - 0.25 to 0.5 m
 - 0.5 to 1.0 m
 - 1.0 to 1.5 m
 - 1.5 to 2.0 m
 - 2.0 to 2.5 m
 - 2.5 to 3.0 m
 - 3.0 to 3.5 m
 - 3.5 to 4.0 m
 - 4.0 to 4.5 m
 - > 4.5 m

Modelling results are based on the best available elevation resolution: Copernicus. The available LiDAR data indicates areas where the elevation and therefore hydraulic model are inconsistent with local survey. All model results should be considered indicative and subject to broader survey validation.

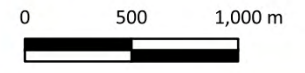

**Calvale to Calliope TL
Surface Water
Impact Assessment**

0.2% (1in500) AEP 2090-SSP3
Results
Page 8/18



WATER + ENVIRONMENT



- Legend**
- Project Area
 - Towers
 - 1 m LiDAR Extent
 - Disturbance Footprint
 - Indicative Access Tracks

- Flood depth (m)**
- up to 0.25 m
 - 0.25 to 0.5 m
 - 0.5 to 1.0 m
 - 1.0 to 1.5 m
 - 1.5 to 2.0 m
 - 2.0 to 2.5 m
 - 2.5 to 3.0 m
 - 3.0 to 3.5 m
 - 3.5 to 4.0 m
 - 4.0 to 4.5 m
 - > 4.5 m

Modelling results are based on the best available elevation resolution: Copernicus. The available LiDAR data indicates areas where the elevation and therefore hydraulic model are inconsistent with local survey. All model results should be considered indicative and subject to broader survey validation.



**Calvale to Calliope TL
Surface Water
Impact Assessment**

0.2% (1in500) AEP 2090-SSP3
Results
Page 9/18



WATER + ENVIRONMENT

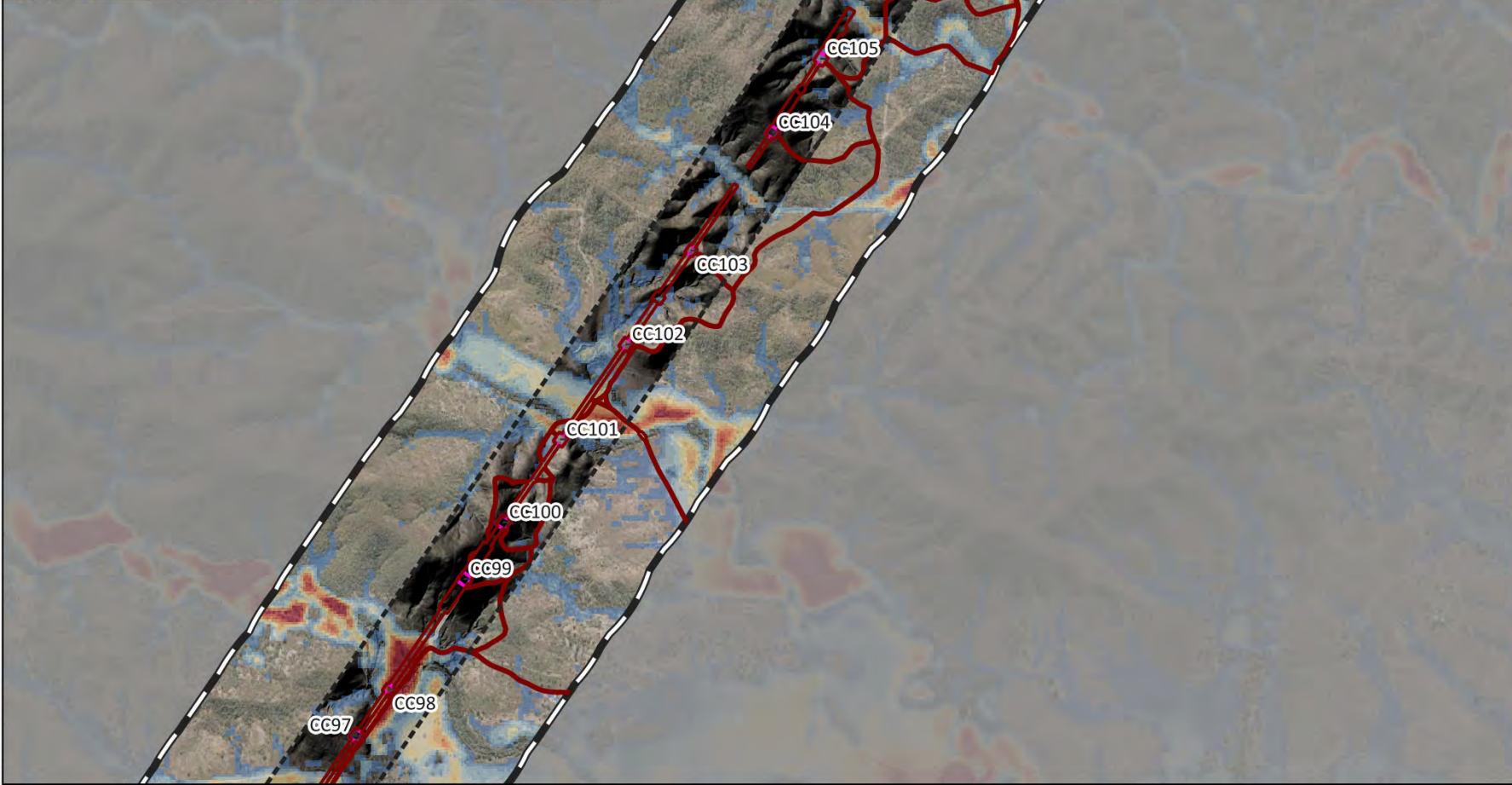
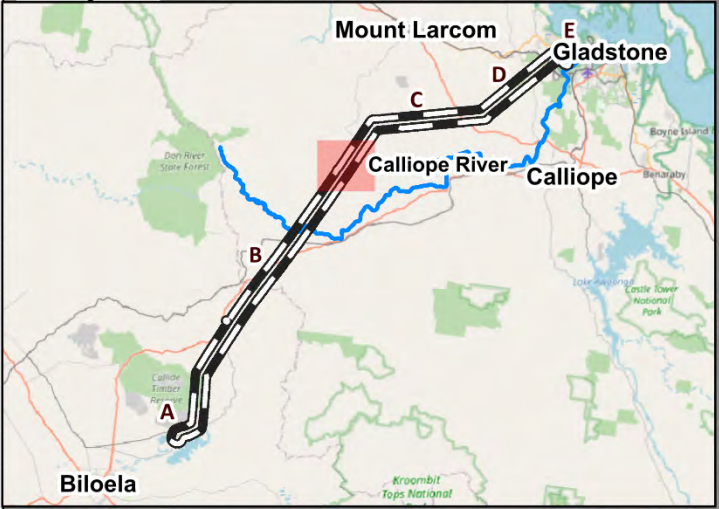

- Legend**
- Project Area
 - Towers
 - 1 m LiDAR Extent
 - Disturbance Footprint
 - Indicative Access Tracks

- Flood depth (m)**
- up to 0.25 m
 - 0.25 to 0.5 m
 - 0.5 to 1.0 m
 - 1.0 to 1.5 m
 - 1.5 to 2.0 m
 - 2.0 to 2.5 m
 - 2.5 to 3.0 m
 - 3.0 to 3.5 m
 - 3.5 to 4.0 m
 - 4.0 to 4.5 m
 - > 4.5 m

Modelling results are based on the best available elevation resolution: Copernicus. The available LiDAR data indicates areas where the elevation and therefore hydraulic model are inconsistent with local survey. All model results should be considered indicative and subject to broader survey validation.

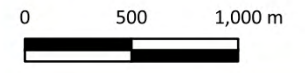

**Calvale to Calliope TL
Surface Water
Impact Assessment**

0.2% (1in500) AEP 2090-SSP3
Results
Page 10/18



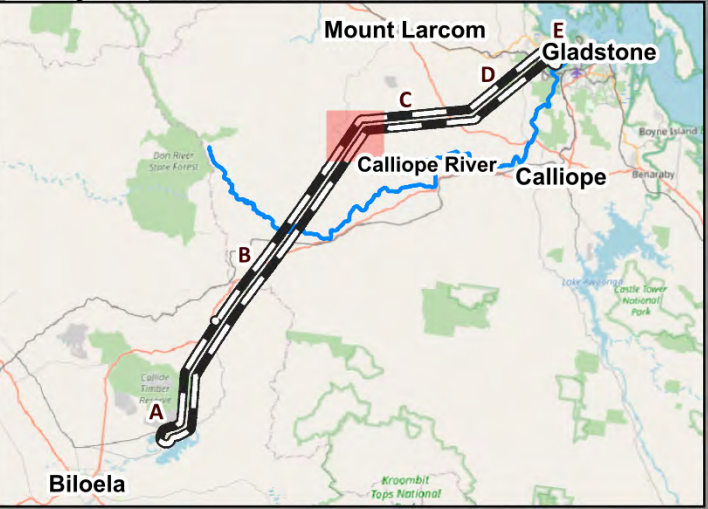

- Legend**
- Project Area
 - Towers
 - 1 m LiDAR Extent
 - Disturbance Footprint
 - Indicative Access Tracks

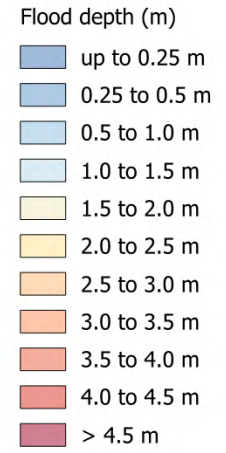

Modelling results are based on the best available elevation resolution: Copernicus. The available LiDAR data indicates areas where the elevation and therefore hydraulic model are inconsistent with local survey. All model results should be considered indicative and subject to broader survey validation.



**Calvale to Calliope TL
Surface Water
Impact Assessment**

0.2% (1in500) AEP 2090-SSP3
Results
Page 11/18



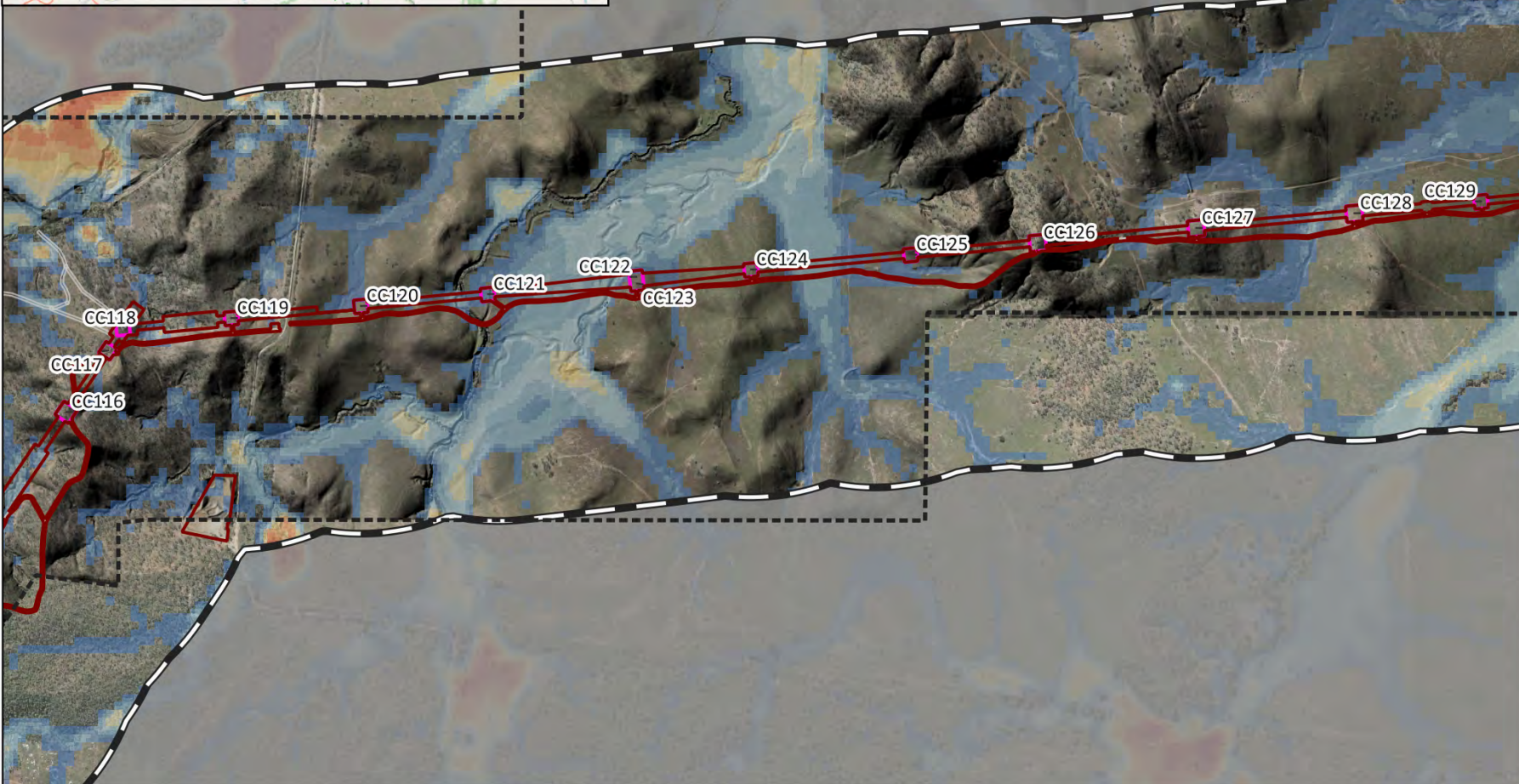
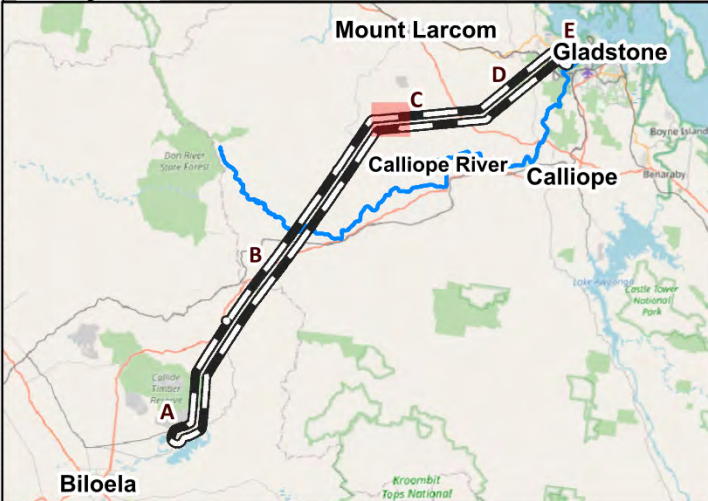

- Legend**
- Project Area
 - Towers
 - 1 m LiDAR Extent
 - Disturbance Footprint
 - Indicative Access Tracks

- Flood depth (m)**
- up to 0.25 m
 - 0.25 to 0.5 m
 - 0.5 to 1.0 m
 - 1.0 to 1.5 m
 - 1.5 to 2.0 m
 - 2.0 to 2.5 m
 - 2.5 to 3.0 m
 - 3.0 to 3.5 m
 - 3.5 to 4.0 m
 - 4.0 to 4.5 m
 - > 4.5 m

Modelling results are based on the best available elevation resolution: Copernicus. The available LiDAR data indicates areas where the elevation and therefore hydraulic model are inconsistent with local survey. All model results should be considered indicative and subject to broader survey validation.



**Calvale to Calliope TL
Surface Water
Impact Assessment**

0.2% (1in500) AEP 2090-SSP3
Results
Page 12/18



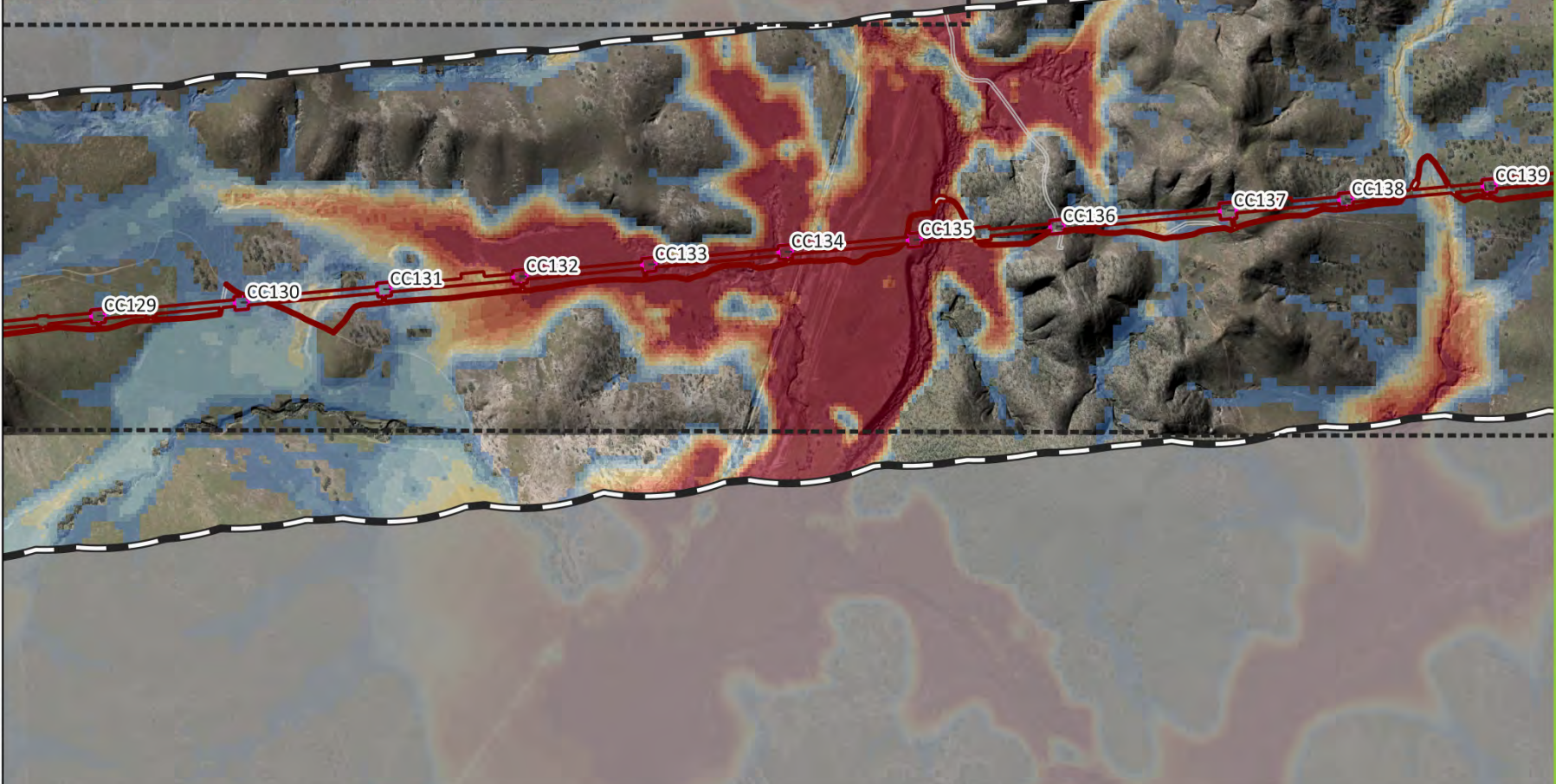
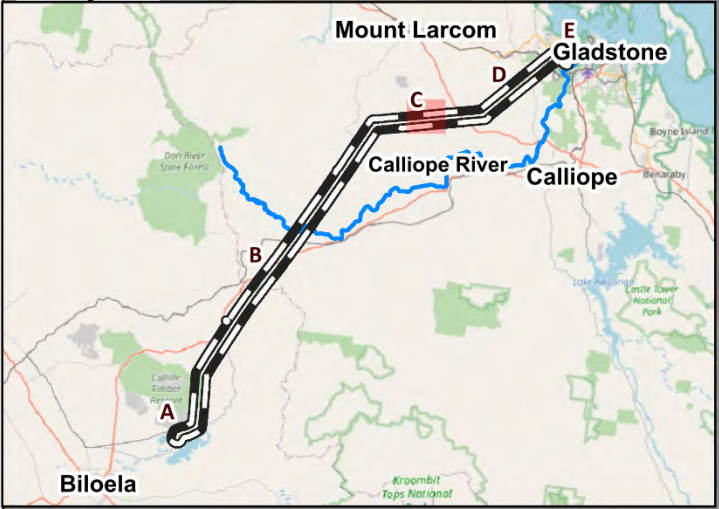

- Legend**
- Project Area
 - Towers
 - 1 m LiDAR Extent
 - Disturbance Footprint
 - Indicative Access Tracks

- Flood depth (m)**
- up to 0.25 m
 - 0.25 to 0.5 m
 - 0.5 to 1.0 m
 - 1.0 to 1.5 m
 - 1.5 to 2.0 m
 - 2.0 to 2.5 m
 - 2.5 to 3.0 m
 - 3.0 to 3.5 m
 - 3.5 to 4.0 m
 - 4.0 to 4.5 m
 - > 4.5 m

Modelling results are based on the best available elevation resolution: Copernicus. The available LiDAR data indicates areas where the elevation and therefore hydraulic model are inconsistent with local survey. All model results should be considered indicative and subject to broader survey validation.



**Calvale to Calliope TL
Surface Water
Impact Assessment**

0.2% (1in500) AEP 2090-SSP3
Results
Page 13/18



WATER + ENVIRONMENT

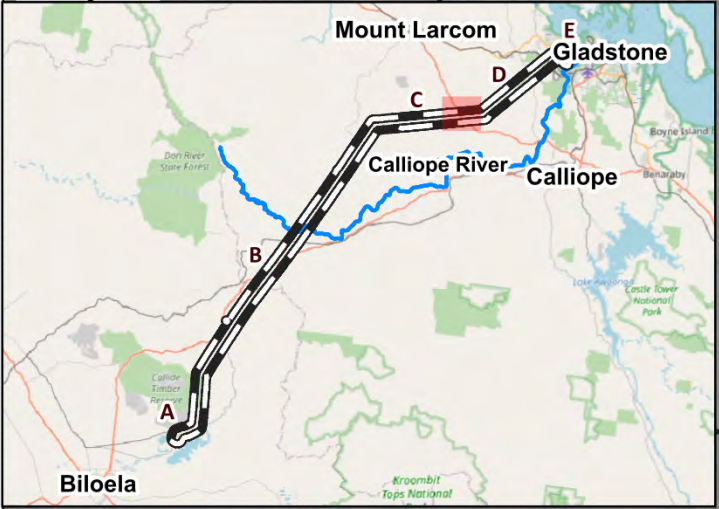

Biloela

Mount Larcum Gladstone

Calliope River Calliope

A B C D E

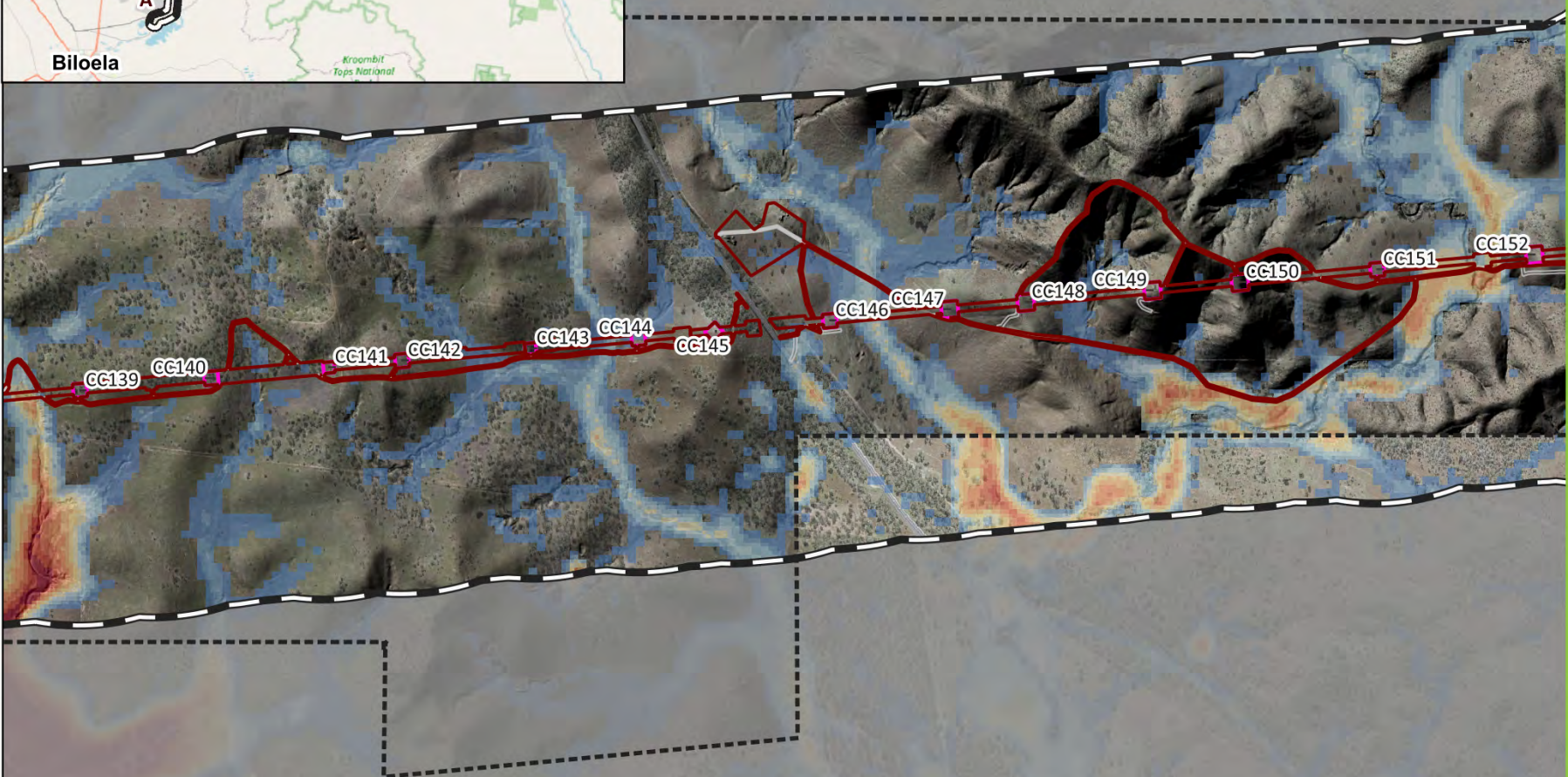

- Legend**
- Project Area
 - Towers
 - 1 m LiDAR Extent
 - Disturbance Footprint
 - Indicative Access Tracks

- Flood depth (m)**
- up to 0.25 m
 - 0.25 to 0.5 m
 - 0.5 to 1.0 m
 - 1.0 to 1.5 m
 - 1.5 to 2.0 m
 - 2.0 to 2.5 m
 - 2.5 to 3.0 m
 - 3.0 to 3.5 m
 - 3.5 to 4.0 m
 - 4.0 to 4.5 m
 - > 4.5 m

Modelling results are based on the best available elevation resolution: Copernicus. The available LiDAR data indicates areas where the elevation and therefore hydraulic model are inconsistent with local survey. All model results should be considered indicative and subject to broader survey validation.

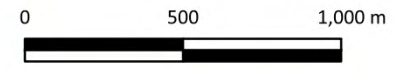

**Calvale to Calliope TL
Surface Water
Impact Assessment**

0.2% (1in500) AEP 2090-SSP3
Results
Page 14/18



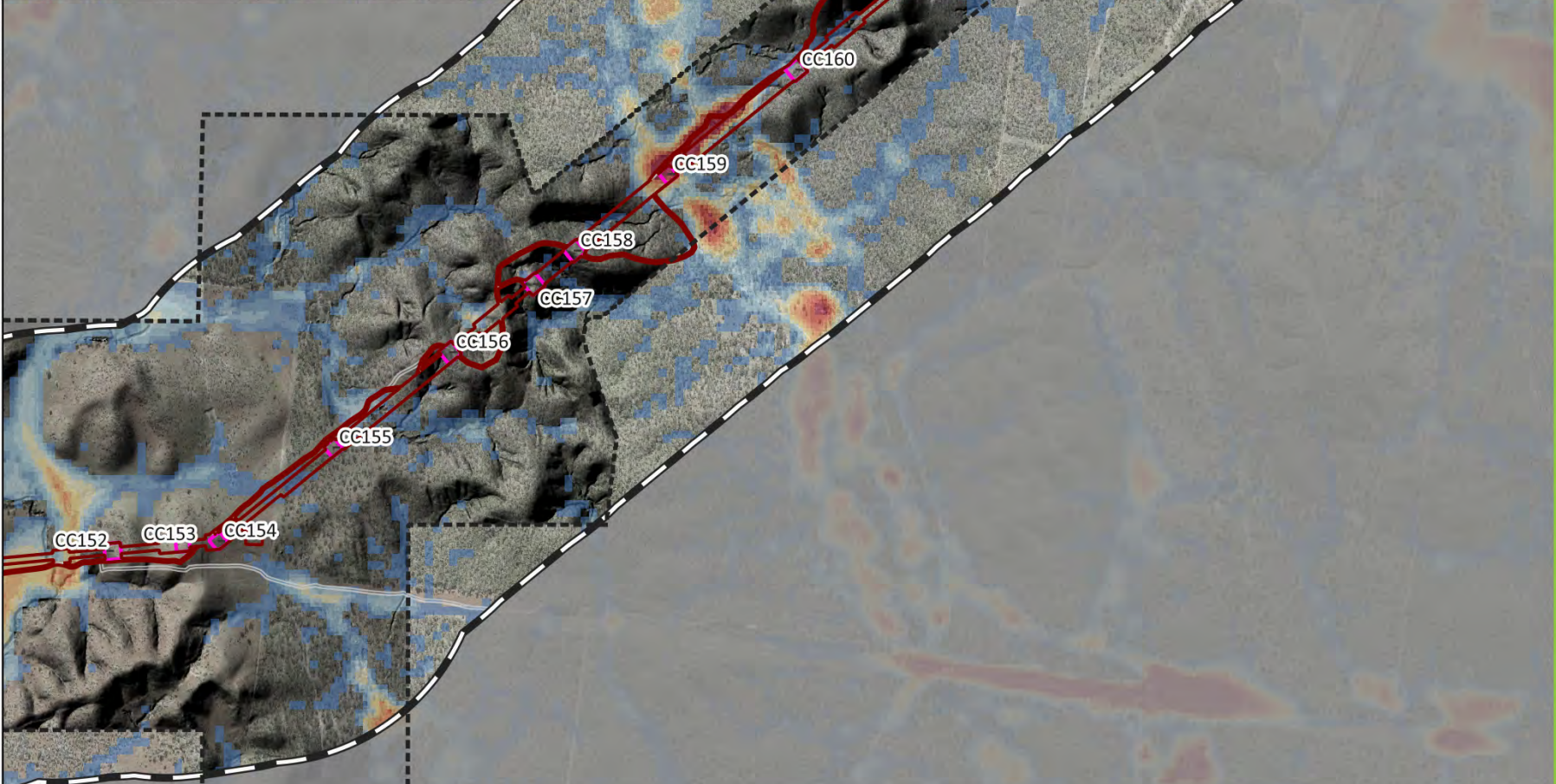

- Legend**
- Project Area
 - Towers
 - 1 m LiDAR Extent
 - Disturbance Footprint
 - Indicative Access Tracks

- Flood depth (m)**
- up to 0.25 m
 - 0.25 to 0.5 m
 - 0.5 to 1.0 m
 - 1.0 to 1.5 m
 - 1.5 to 2.0 m
 - 2.0 to 2.5 m
 - 2.5 to 3.0 m
 - 3.0 to 3.5 m
 - 3.5 to 4.0 m
 - 4.0 to 4.5 m
 - > 4.5 m

Modelling results are based on the best available elevation resolution: Copernicus. The available LiDAR data indicates areas where the elevation and therefore hydraulic model are inconsistent with local survey. All model results should be considered indicative and subject to broader survey validation.



**Calvale to Calliope TL
Surface Water
Impact Assessment**

0.2% (1in500) AEP 2090-SSP3
Results
Page 15/18



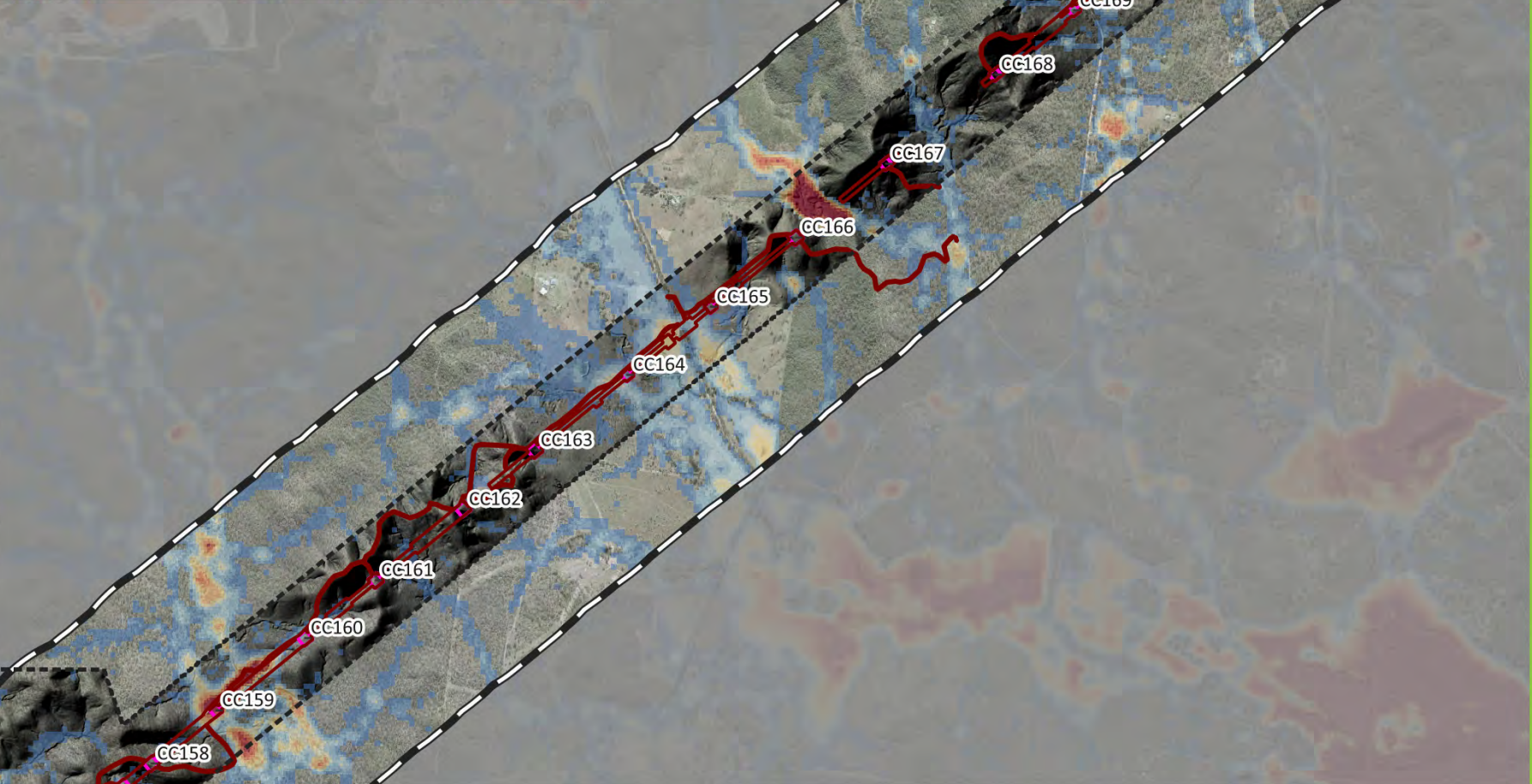

- Legend**
- Project Area
 - Towers
 - 1 m LiDAR Extent
 - Disturbance Footprint
 - Indicative Access Tracks

- Flood depth (m)**
- up to 0.25 m
 - 0.25 to 0.5 m
 - 0.5 to 1.0 m
 - 1.0 to 1.5 m
 - 1.5 to 2.0 m
 - 2.0 to 2.5 m
 - 2.5 to 3.0 m
 - 3.0 to 3.5 m
 - 3.5 to 4.0 m
 - 4.0 to 4.5 m
 - > 4.5 m

Modelling results are based on the best available elevation resolution: Copernicus. The available LiDAR data indicates areas where the elevation and therefore hydraulic model are inconsistent with local survey. All model results should be considered indicative and subject to broader survey validation.

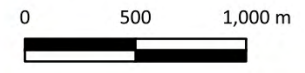

**Calvale to Calliope TL
Surface Water
Impact Assessment**

0.2% (1in500) AEP 2090-SSP3
Results
Page 16/18



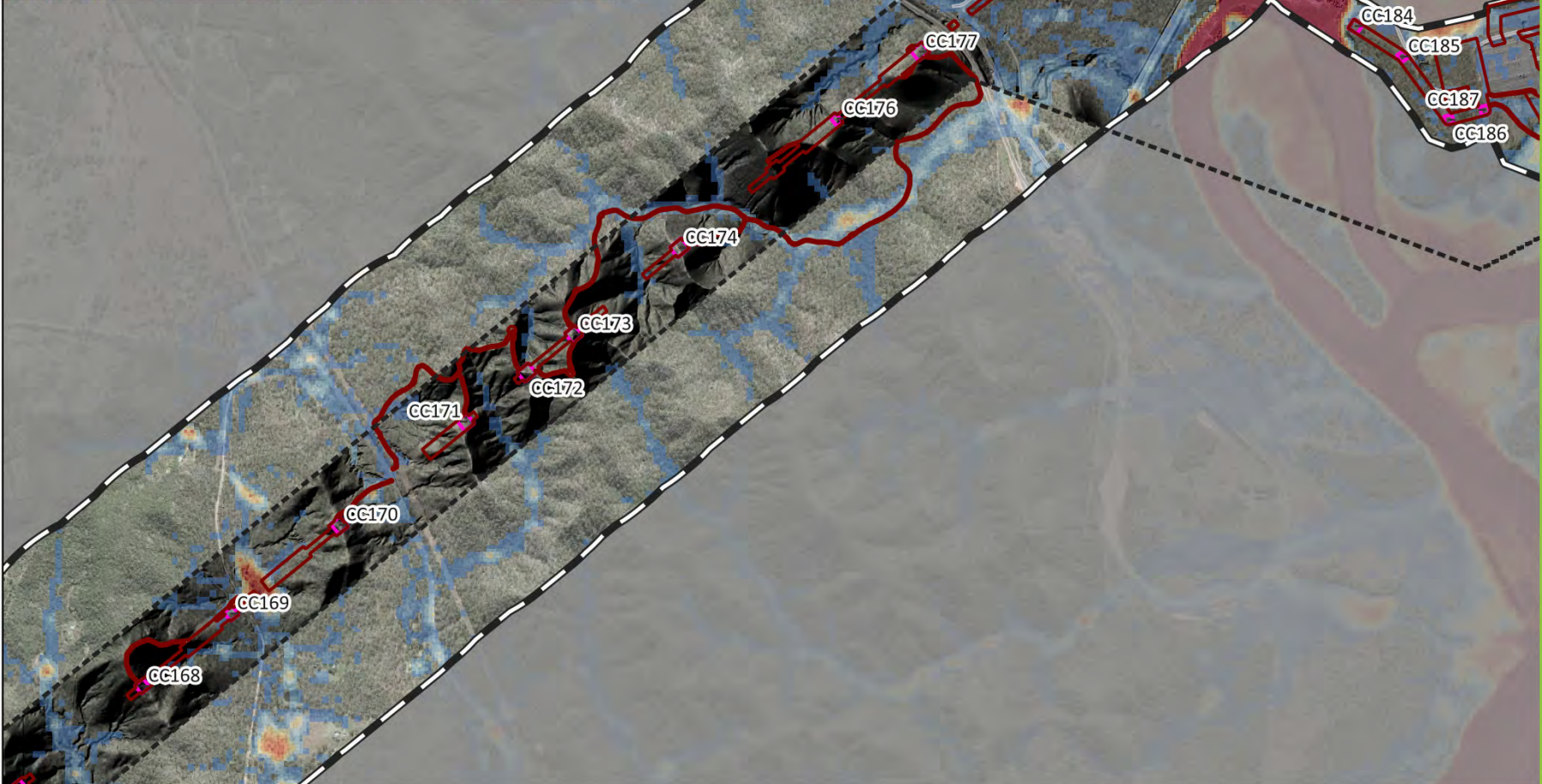

- Legend**
- Project Area
 - Towers
 - 1 m LiDAR Extent
 - Disturbance Footprint
 - Indicative Access Tracks

- Flood depth (m)**
- up to 0.25 m
 - 0.25 to 0.5 m
 - 0.5 to 1.0 m
 - 1.0 to 1.5 m
 - 1.5 to 2.0 m
 - 2.0 to 2.5 m
 - 2.5 to 3.0 m
 - 3.0 to 3.5 m
 - 3.5 to 4.0 m
 - 4.0 to 4.5 m
 - > 4.5 m

Modelling results are based on the best available elevation resolution: Copernicus. The available LiDAR data indicates areas where the elevation and therefore hydraulic model are inconsistent with local survey. All model results should be considered indicative and subject to broader survey validation.



**Calvale to Calliope TL
Surface Water
Impact Assessment**

0.2% (1in500) AEP 2090-SSP3
Results
Page 17/18



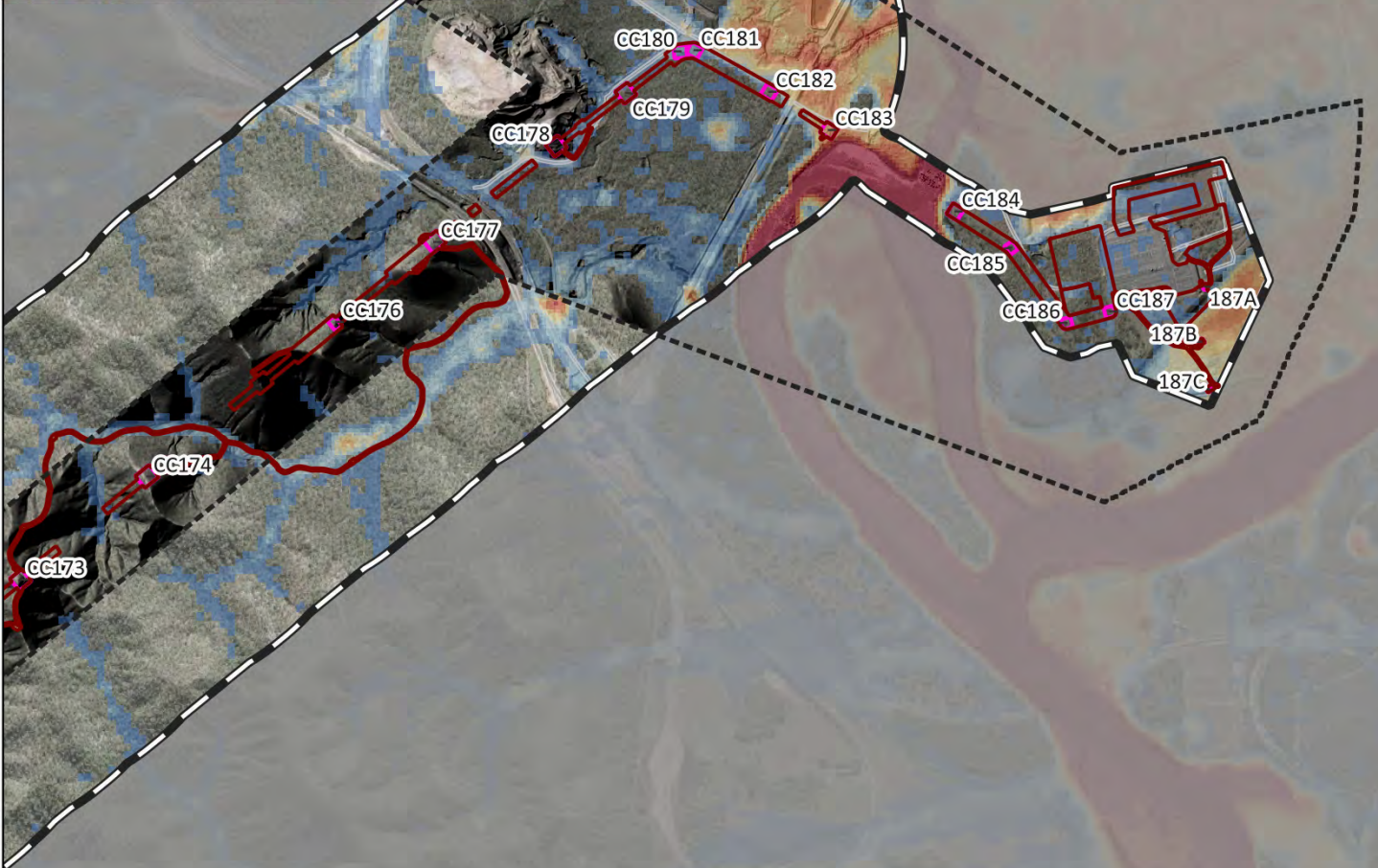

- Legend**
- Project Area
 - Towers
 - 1 m LiDAR Extent
 - Disturbance Footprint
 - Indicative Access Tracks

- Flood depth (m)**
- up to 0.25 m
 - 0.25 to 0.5 m
 - 0.5 to 1.0 m
 - 1.0 to 1.5 m
 - 1.5 to 2.0 m
 - 2.0 to 2.5 m
 - 2.5 to 3.0 m
 - 3.0 to 3.5 m
 - 3.5 to 4.0 m
 - 4.0 to 4.5 m
 - > 4.5 m

Modelling results are based on the best available elevation resolution: Copernicus. The available LiDAR data indicates areas where the elevation and therefore hydraulic model are inconsistent with local survey. All model results should be considered indicative and subject to broader survey validation.



**Calvale to Calliope TL
Surface Water
Impact Assessment**

0.2% (1in500) AEP 2090-SSP3
Results
Page 18/18



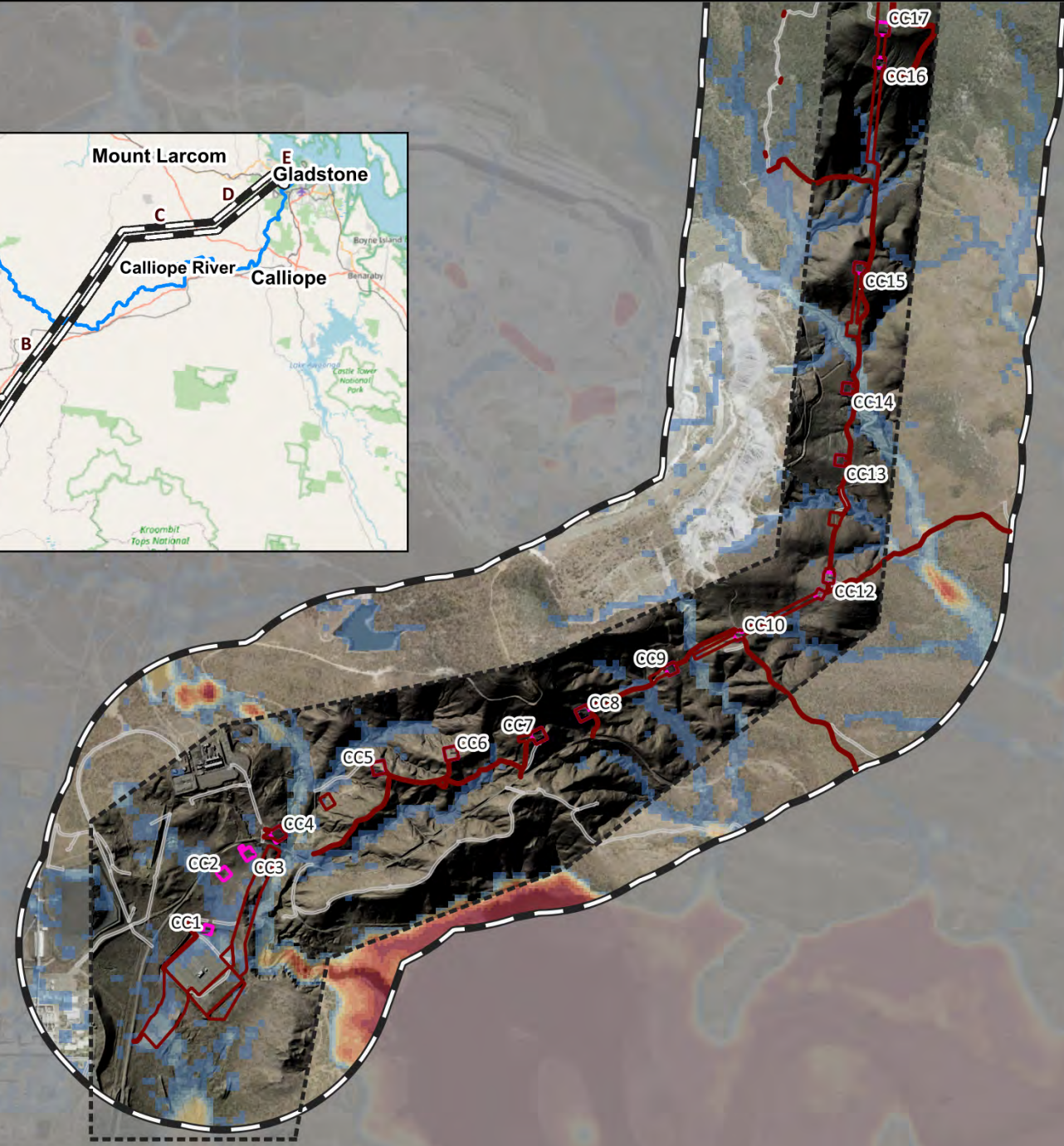

- Legend**
- Project Area
 - Towers
 - 1 m LiDAR Extent
 - Disturbance Footprint
 - Indicative Access Tracks

- Flood depth (m)**
- up to 0.25 m
 - 0.25 to 0.5 m
 - 0.5 to 1.0 m
 - 1.0 to 1.5 m
 - 1.5 to 2.0 m
 - 2.0 to 2.5 m
 - 2.5 to 3.0 m
 - 3.0 to 3.5 m
 - 3.5 to 4.0 m
 - 4.0 to 4.5 m
 - > 4.5 m

Modelling results are based on the best available elevation resolution: Copernicus. The available LiDAR data indicates areas where the elevation and therefore hydraulic model are inconsistent with local survey. All model results should be considered indicative and subject to broader survey validation.

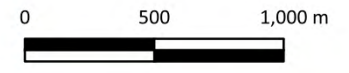

Calvale to Calliope TL Surface Water Impact Assessment

1% AEP 2090-SSP3 Results
Page 1/18



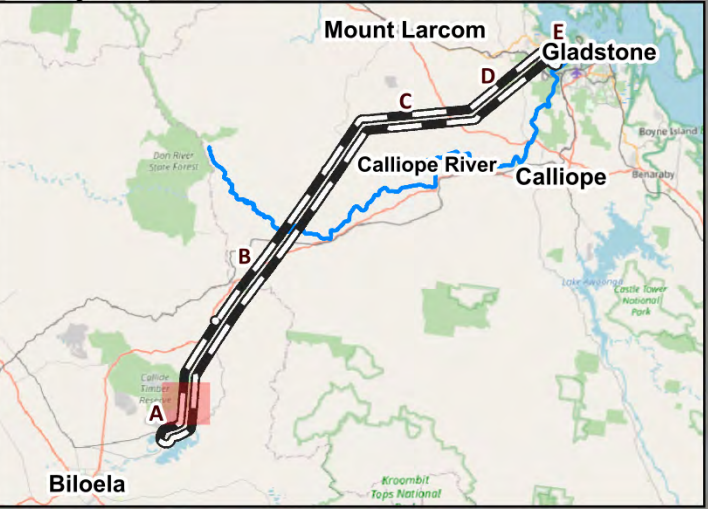

- Legend**
- Project Area
 - Towers
 - 1 m LiDAR Extent
 - Disturbance Footprint
 - Indicative Access Tracks

- Flood depth (m)**
- up to 0.25 m
 - 0.25 to 0.5 m
 - 0.5 to 1.0 m
 - 1.0 to 1.5 m
 - 1.5 to 2.0 m
 - 2.0 to 2.5 m
 - 2.5 to 3.0 m
 - 3.0 to 3.5 m
 - 3.5 to 4.0 m
 - 4.0 to 4.5 m
 - > 4.5 m

Modelling results are based on the best available elevation resolution: Copernicus. The available LiDAR data indicates areas where the elevation and therefore hydraulic model are inconsistent with local survey. All model results should be considered indicative and subject to broader survey validation.



**Calvale to Calliope TL
Surface Water
Impact Assessment**

1% AEP 2090-SSP3 Results
Page 2/18





- Legend**
- Project Area
 - Towers
 - 1 m LiDAR Extent
 - Disturbance Footprint
 - Indicative Access Tracks

- Flood depth (m)**
- up to 0.25 m
 - 0.25 to 0.5 m
 - 0.5 to 1.0 m
 - 1.0 to 1.5 m
 - 1.5 to 2.0 m
 - 2.0 to 2.5 m
 - 2.5 to 3.0 m
 - 3.0 to 3.5 m
 - 3.5 to 4.0 m
 - 4.0 to 4.5 m
 - > 4.5 m

Modelling results are based on the best available elevation resolution: Copernicus. The available LiDAR data indicates areas where the elevation and therefore hydraulic model are inconsistent with local survey. All model results should be considered indicative and subject to broader survey validation.

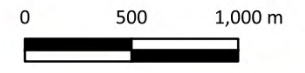

**Calvale to Calliope TL
Surface Water
Impact Assessment**

1% AEP 2090-SSP3 Results
Page 3/18



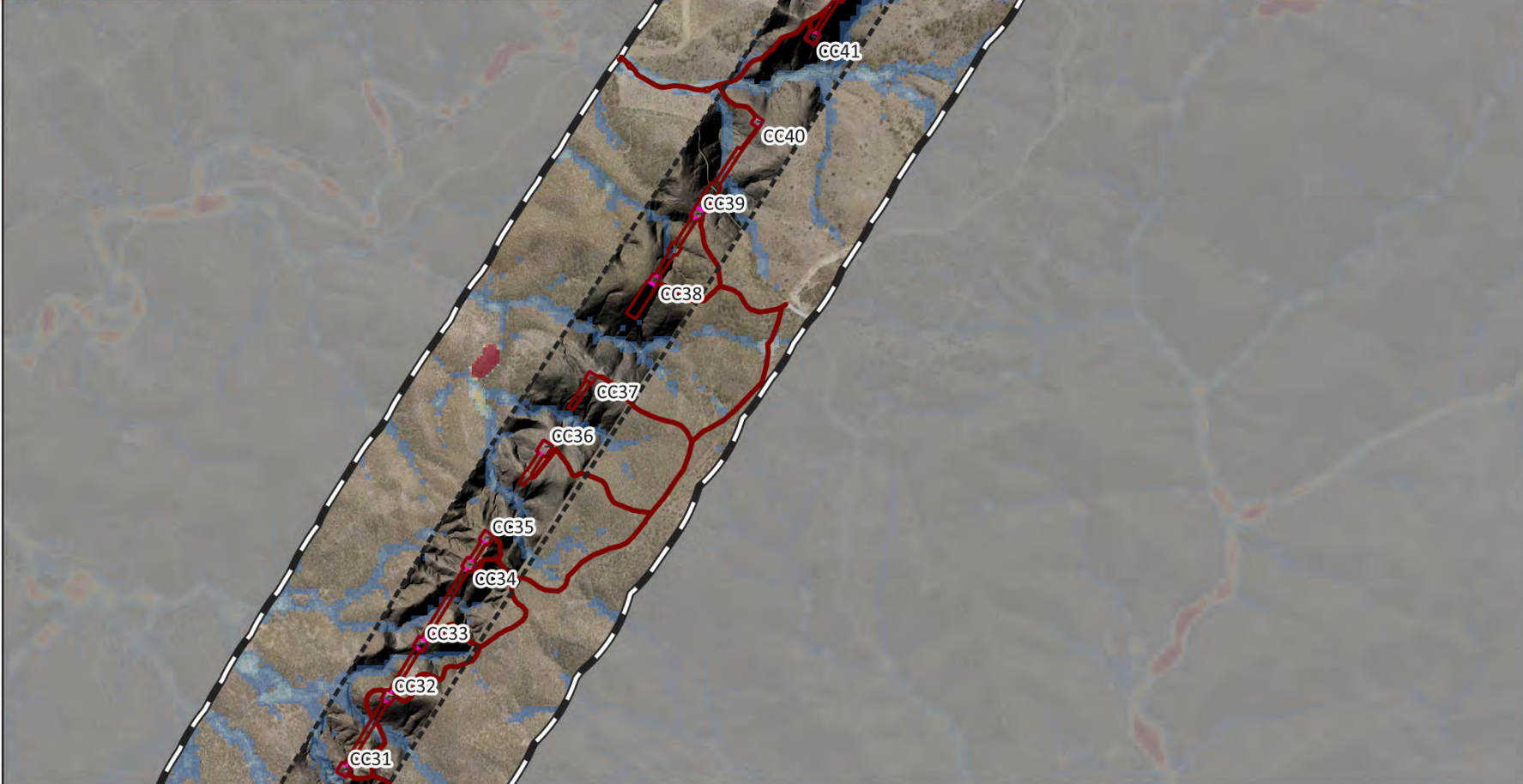

- Legend**
- Project Area
 - Towers
 - 1 m LiDAR Extent
 - Disturbance Footprint
 - Indicative Access Tracks

- Flood depth (m)**
- up to 0.25 m
 - 0.25 to 0.5 m
 - 0.5 to 1.0 m
 - 1.0 to 1.5 m
 - 1.5 to 2.0 m
 - 2.0 to 2.5 m
 - 2.5 to 3.0 m
 - 3.0 to 3.5 m
 - 3.5 to 4.0 m
 - 4.0 to 4.5 m
 - > 4.5 m

Modelling results are based on the best available elevation resolution: Copernicus. The available LiDAR data indicates areas where the elevation and therefore hydraulic model are inconsistent with local survey. All model results should be considered indicative and subject to broader survey validation.



**Calvale to Calliope TL
Surface Water
Impact Assessment**

1% AEP 2090-SSP3 Results
Page 4/18



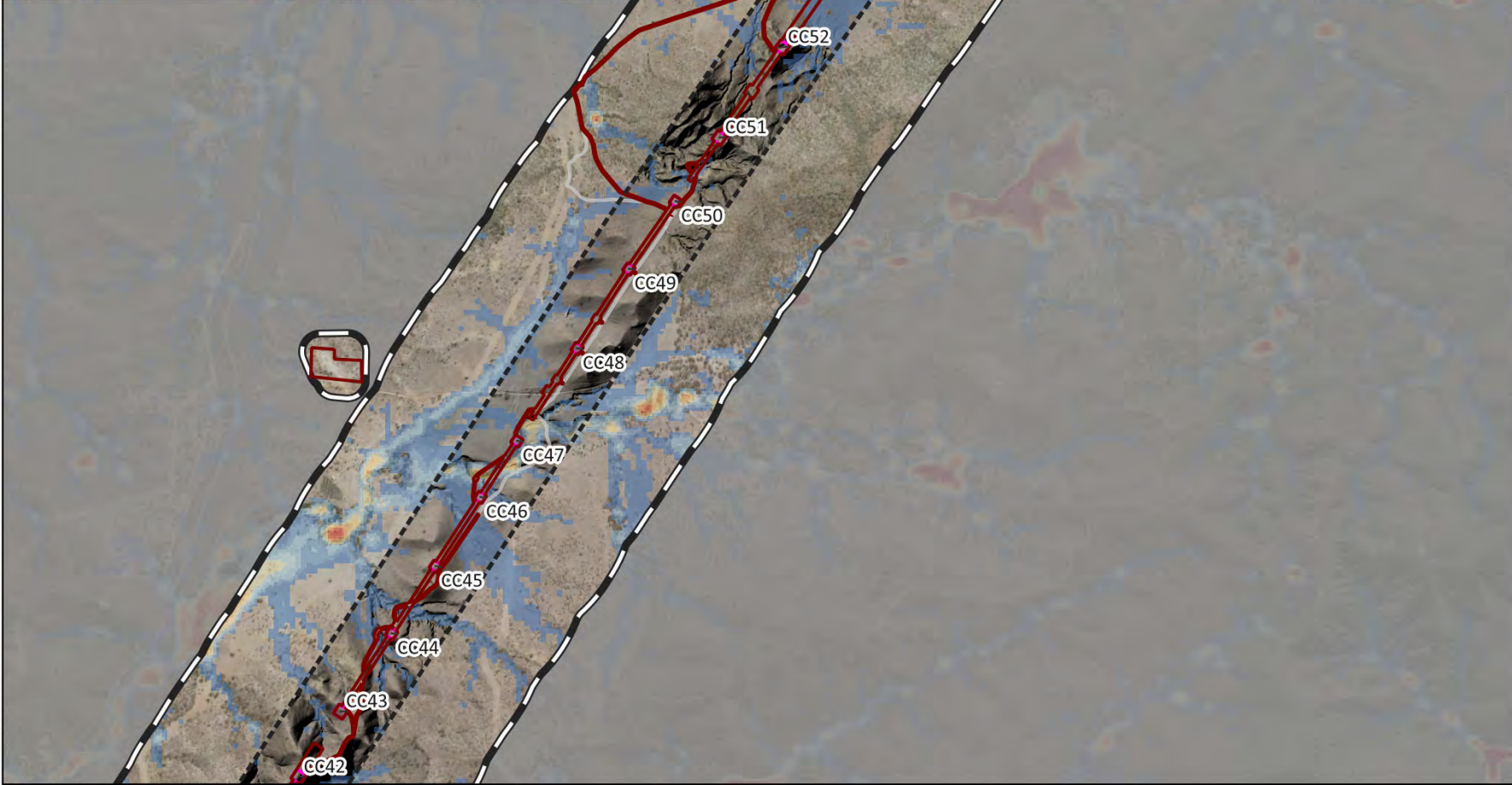

- Legend**
- Project Area
 - Towers
 - 1 m LiDAR Extent
 - Disturbance Footprint
 - Indicative Access Tracks

- Flood depth (m)**
- up to 0.25 m
 - 0.25 to 0.5 m
 - 0.5 to 1.0 m
 - 1.0 to 1.5 m
 - 1.5 to 2.0 m
 - 2.0 to 2.5 m
 - 2.5 to 3.0 m
 - 3.0 to 3.5 m
 - 3.5 to 4.0 m
 - 4.0 to 4.5 m
 - > 4.5 m

Modelling results are based on the best available elevation resolution: Copernicus. The available LiDAR data indicates areas where the elevation and therefore hydraulic model are inconsistent with local survey. All model results should be considered indicative and subject to broader survey validation.

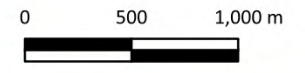

**Calvale to Calliope TL
Surface Water
Impact Assessment**

1% AEP 2090-SSP3 Results
Page 5/18



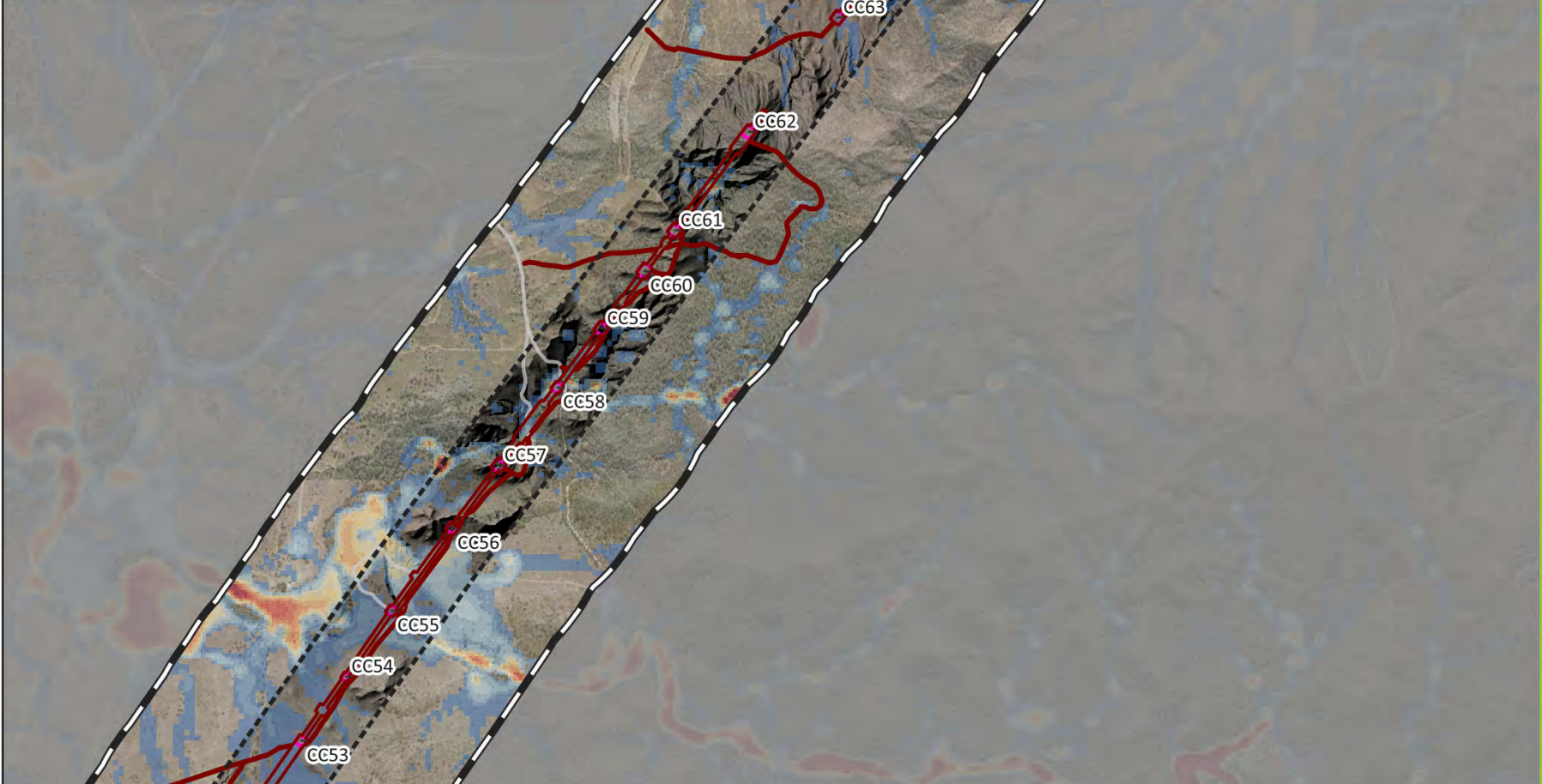

- Legend**
- Project Area
 - Towers
 - 1 m LiDAR Extent
 - Disturbance Footprint
 - Indicative Access Tracks

- Flood depth (m)**
- up to 0.25 m
 - 0.25 to 0.5 m
 - 0.5 to 1.0 m
 - 1.0 to 1.5 m
 - 1.5 to 2.0 m
 - 2.0 to 2.5 m
 - 2.5 to 3.0 m
 - 3.0 to 3.5 m
 - 3.5 to 4.0 m
 - 4.0 to 4.5 m
 - > 4.5 m

Modelling results are based on the best available elevation resolution: Copernicus. The available LiDAR data indicates areas where the elevation and therefore hydraulic model are inconsistent with local survey. All model results should be considered indicative and subject to broader survey validation.



**Calvale to Calliope TL
Surface Water
Impact Assessment**

1% AEP 2090-SSP3 Results
Page 6/18



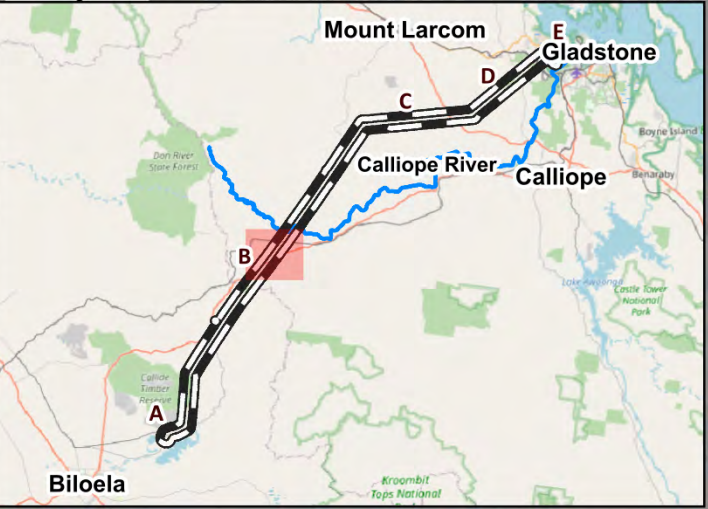
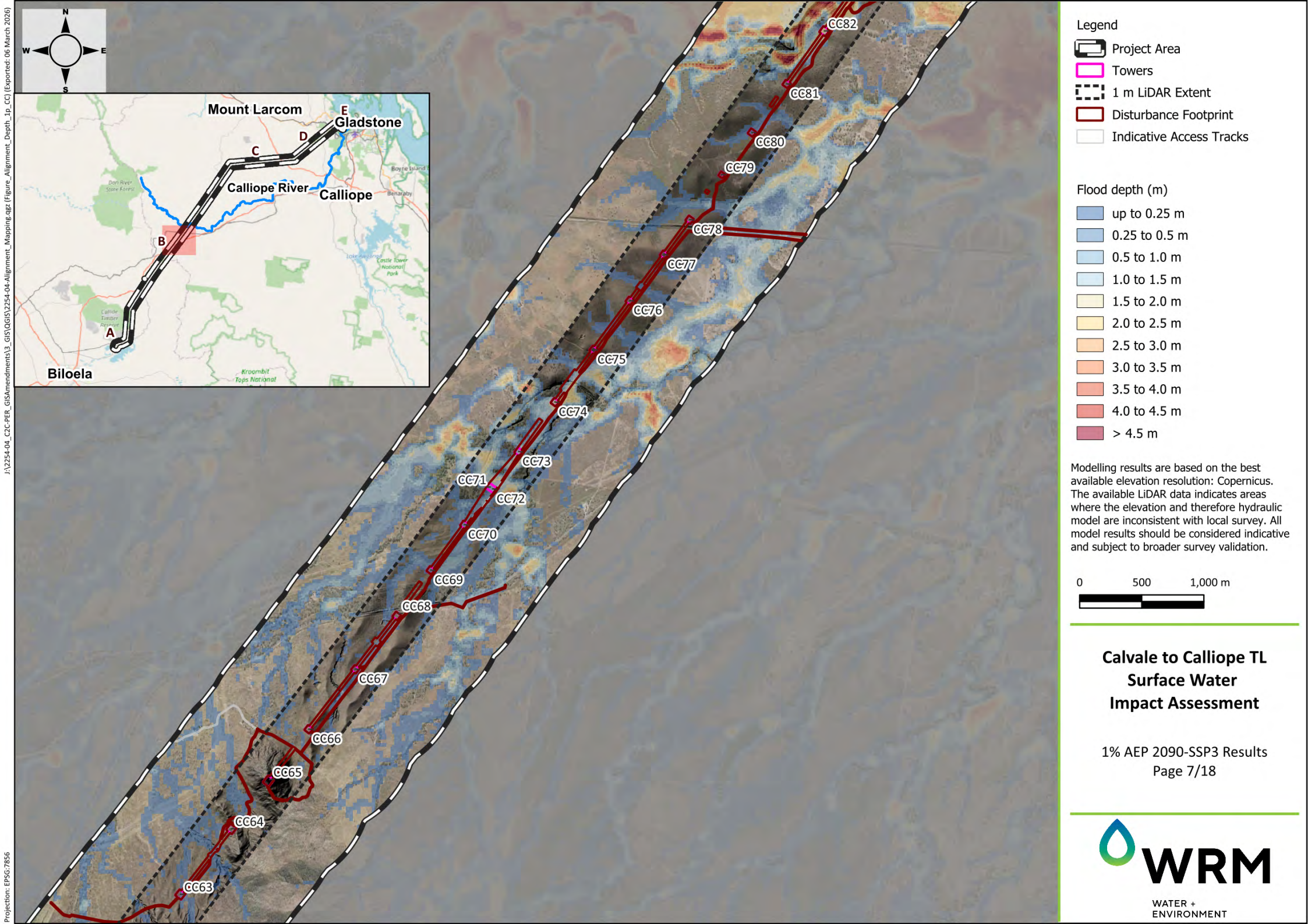

- Legend**
- Project Area
 - Towers
 - 1 m LiDAR Extent
 - Disturbance Footprint
 - Indicative Access Tracks

- Flood depth (m)**
- up to 0.25 m
 - 0.25 to 0.5 m
 - 0.5 to 1.0 m
 - 1.0 to 1.5 m
 - 1.5 to 2.0 m
 - 2.0 to 2.5 m
 - 2.5 to 3.0 m
 - 3.0 to 3.5 m
 - 3.5 to 4.0 m
 - 4.0 to 4.5 m
 - > 4.5 m

Modelling results are based on the best available elevation resolution: Copernicus. The available LiDAR data indicates areas where the elevation and therefore hydraulic model are inconsistent with local survey. All model results should be considered indicative and subject to broader survey validation.

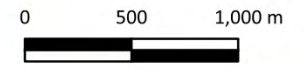

**Calvale to Calliope TL
Surface Water
Impact Assessment**

1% AEP 2090-SSP3 Results
Page 7/18



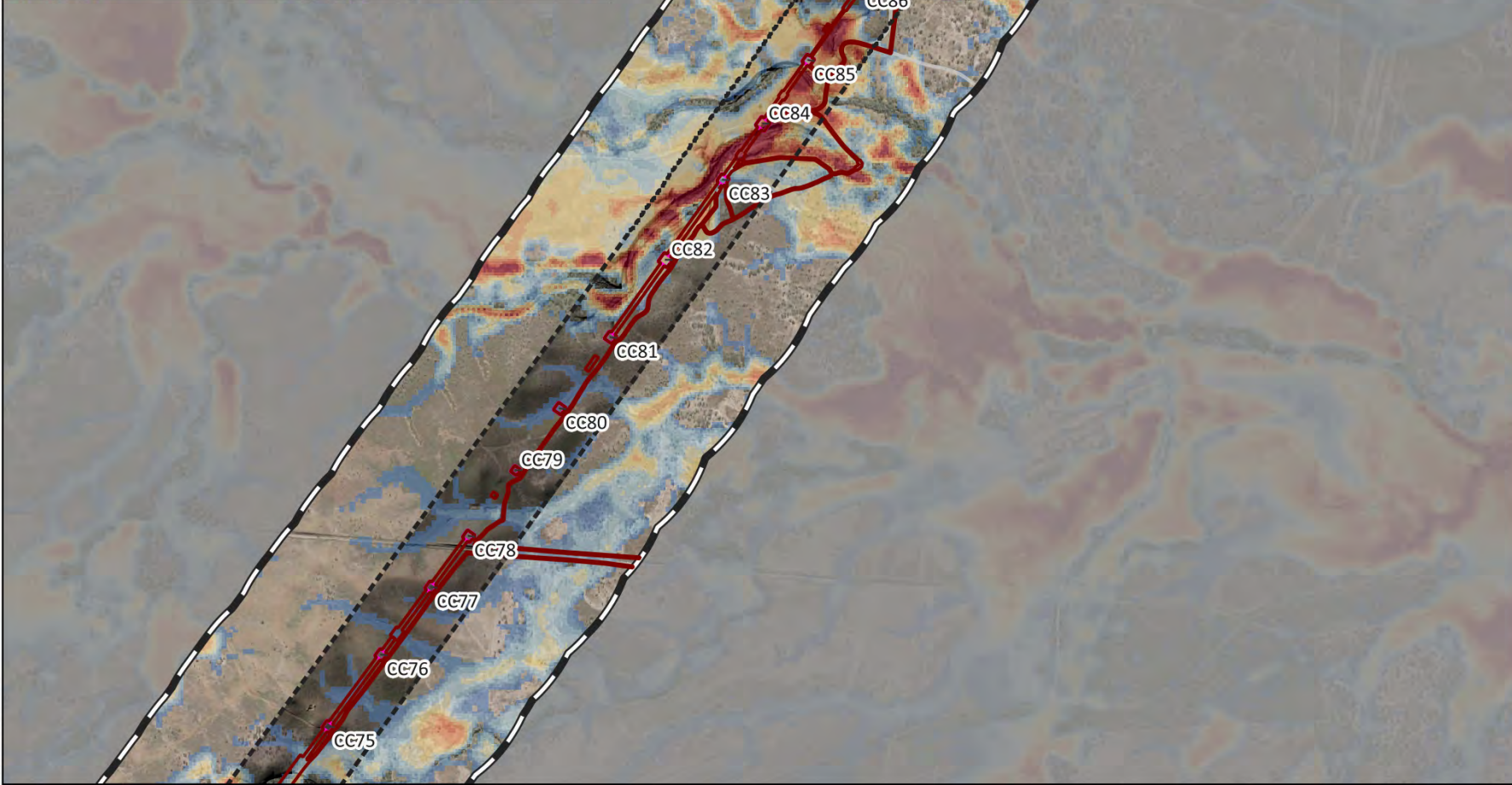
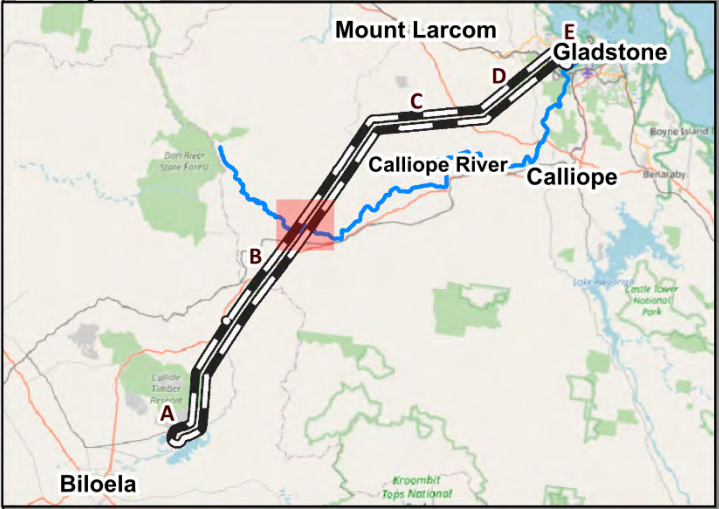

- Legend**
- Project Area
 - Towers
 - 1 m LiDAR Extent
 - Disturbance Footprint
 - Indicative Access Tracks

- Flood depth (m)**
- up to 0.25 m
 - 0.25 to 0.5 m
 - 0.5 to 1.0 m
 - 1.0 to 1.5 m
 - 1.5 to 2.0 m
 - 2.0 to 2.5 m
 - 2.5 to 3.0 m
 - 3.0 to 3.5 m
 - 3.5 to 4.0 m
 - 4.0 to 4.5 m
 - > 4.5 m

Modelling results are based on the best available elevation resolution: Copernicus. The available LiDAR data indicates areas where the elevation and therefore hydraulic model are inconsistent with local survey. All model results should be considered indicative and subject to broader survey validation.



**Calvale to Calliope TL
Surface Water
Impact Assessment**

1% AEP 2090-SSP3 Results
Page 8/18





- Legend**
- Project Area
 - Towers
 - 1 m LiDAR Extent
 - Disturbance Footprint
 - Indicative Access Tracks

- Flood depth (m)**
- up to 0.25 m
 - 0.25 to 0.5 m
 - 0.5 to 1.0 m
 - 1.0 to 1.5 m
 - 1.5 to 2.0 m
 - 2.0 to 2.5 m
 - 2.5 to 3.0 m
 - 3.0 to 3.5 m
 - 3.5 to 4.0 m
 - 4.0 to 4.5 m
 - > 4.5 m

Modelling results are based on the best available elevation resolution: Copernicus. The available LiDAR data indicates areas where the elevation and therefore hydraulic model are inconsistent with local survey. All model results should be considered indicative and subject to broader survey validation.

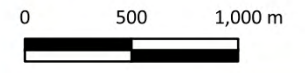

**Calvale to Calliope TL
Surface Water
Impact Assessment**

1% AEP 2090-SSP3 Results
Page 9/18





- Legend**
- Project Area
 - Towers
 - 1 m LiDAR Extent
 - Disturbance Footprint
 - Indicative Access Tracks

- Flood depth (m)**
- up to 0.25 m
 - 0.25 to 0.5 m
 - 0.5 to 1.0 m
 - 1.0 to 1.5 m
 - 1.5 to 2.0 m
 - 2.0 to 2.5 m
 - 2.5 to 3.0 m
 - 3.0 to 3.5 m
 - 3.5 to 4.0 m
 - 4.0 to 4.5 m
 - > 4.5 m

Modelling results are based on the best available elevation resolution: Copernicus. The available LiDAR data indicates areas where the elevation and therefore hydraulic model are inconsistent with local survey. All model results should be considered indicative and subject to broader survey validation.

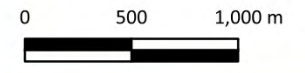

**Calvale to Calliope TL
Surface Water
Impact Assessment**

1% AEP 2090-SSP3 Results
Page 10/18



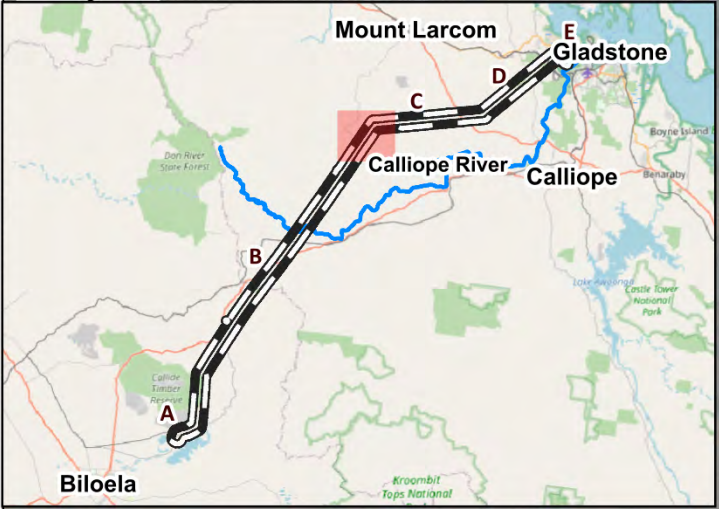

- Legend**
- Project Area
 - Towers
 - 1 m LiDAR Extent
 - Disturbance Footprint
 - Indicative Access Tracks

- Flood depth (m)**
- up to 0.25 m
 - 0.25 to 0.5 m
 - 0.5 to 1.0 m
 - 1.0 to 1.5 m
 - 1.5 to 2.0 m
 - 2.0 to 2.5 m
 - 2.5 to 3.0 m
 - 3.0 to 3.5 m
 - 3.5 to 4.0 m
 - 4.0 to 4.5 m
 - > 4.5 m

Modelling results are based on the best available elevation resolution: Copernicus. The available LiDAR data indicates areas where the elevation and therefore hydraulic model are inconsistent with local survey. All model results should be considered indicative and subject to broader survey validation.



**Calvale to Calliope TL
Surface Water
Impact Assessment**

1% AEP 2090-SSP3 Results
Page 11/18



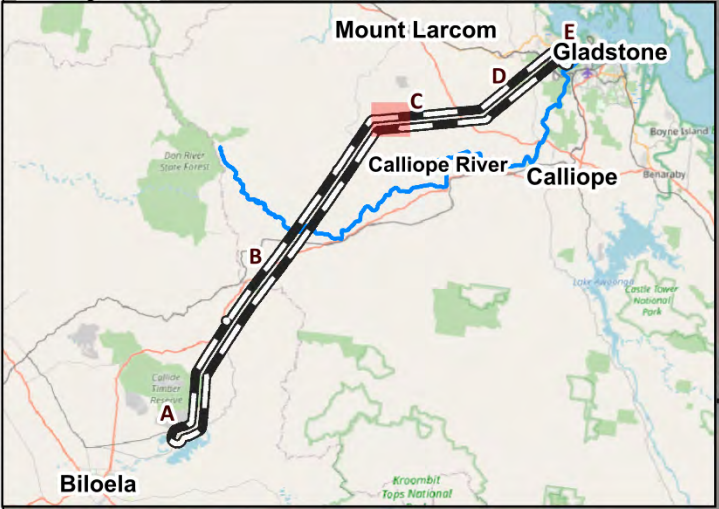

- Legend**
- Project Area
 - Towers
 - 1 m LiDAR Extent
 - Disturbance Footprint
 - Indicative Access Tracks

- Flood depth (m)**
- up to 0.25 m
 - 0.25 to 0.5 m
 - 0.5 to 1.0 m
 - 1.0 to 1.5 m
 - 1.5 to 2.0 m
 - 2.0 to 2.5 m
 - 2.5 to 3.0 m
 - 3.0 to 3.5 m
 - 3.5 to 4.0 m
 - 4.0 to 4.5 m
 - > 4.5 m

Modelling results are based on the best available elevation resolution: Copernicus. The available LiDAR data indicates areas where the elevation and therefore hydraulic model are inconsistent with local survey. All model results should be considered indicative and subject to broader survey validation.

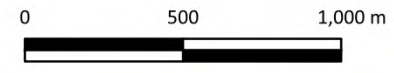

**Calvale to Calliope TL
Surface Water
Impact Assessment**

1% AEP 2090-SSP3 Results
Page 12/18



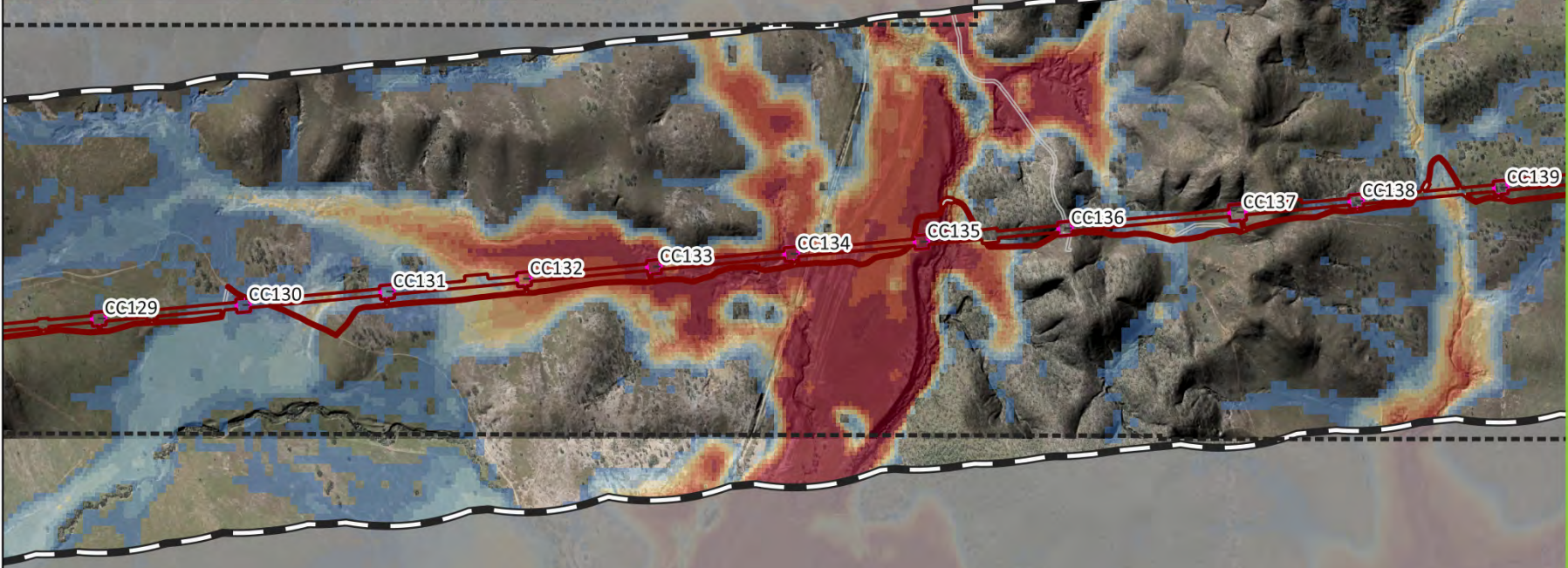
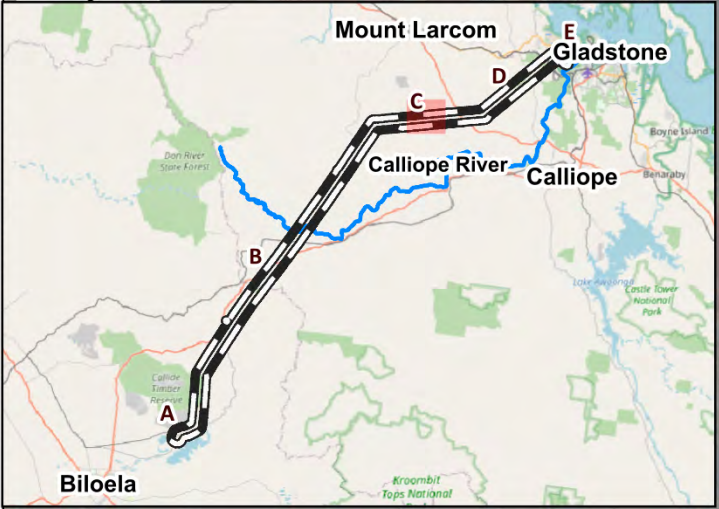

- Legend**
- Project Area
 - Towers
 - 1 m LiDAR Extent
 - Disturbance Footprint
 - Indicative Access Tracks

- Flood depth (m)**
- up to 0.25 m
 - 0.25 to 0.5 m
 - 0.5 to 1.0 m
 - 1.0 to 1.5 m
 - 1.5 to 2.0 m
 - 2.0 to 2.5 m
 - 2.5 to 3.0 m
 - 3.0 to 3.5 m
 - 3.5 to 4.0 m
 - 4.0 to 4.5 m
 - > 4.5 m

Modelling results are based on the best available elevation resolution: Copernicus. The available LiDAR data indicates areas where the elevation and therefore hydraulic model are inconsistent with local survey. All model results should be considered indicative and subject to broader survey validation.



**Calvale to Calliope TL
Surface Water
Impact Assessment**

1% AEP 2090-SSP3 Results
Page 13/18



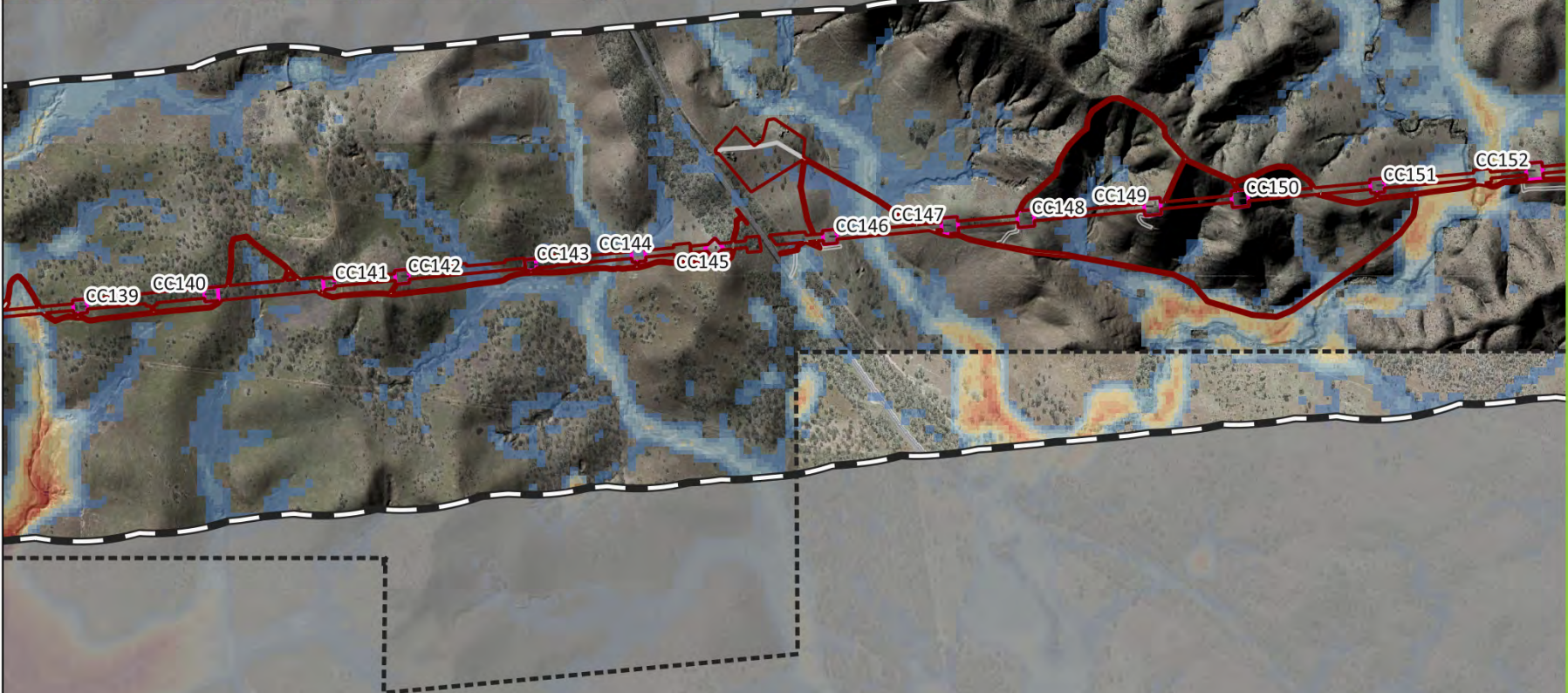
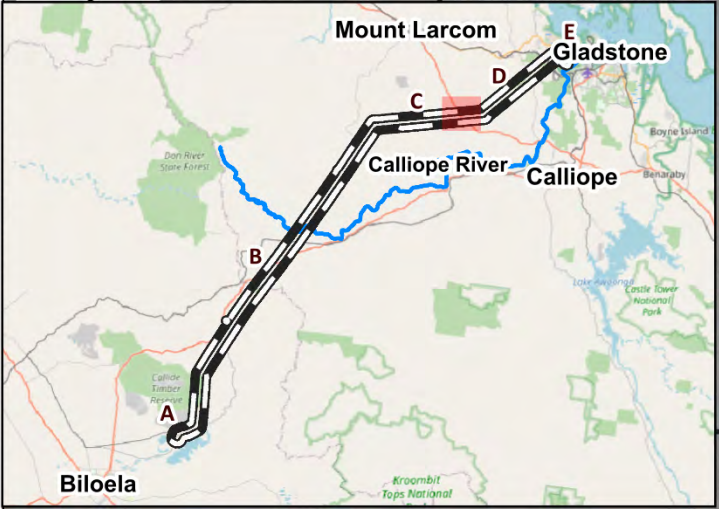

- Legend**
- Project Area
 - Towers
 - 1 m LiDAR Extent
 - Disturbance Footprint
 - Indicative Access Tracks

- Flood depth (m)**
- up to 0.25 m
 - 0.25 to 0.5 m
 - 0.5 to 1.0 m
 - 1.0 to 1.5 m
 - 1.5 to 2.0 m
 - 2.0 to 2.5 m
 - 2.5 to 3.0 m
 - 3.0 to 3.5 m
 - 3.5 to 4.0 m
 - 4.0 to 4.5 m
 - > 4.5 m

Modelling results are based on the best available elevation resolution: Copernicus. The available LiDAR data indicates areas where the elevation and therefore hydraulic model are inconsistent with local survey. All model results should be considered indicative and subject to broader survey validation.



**Calvale to Calliope TL
Surface Water
Impact Assessment**

1% AEP 2090-SSP3 Results
Page 14/18



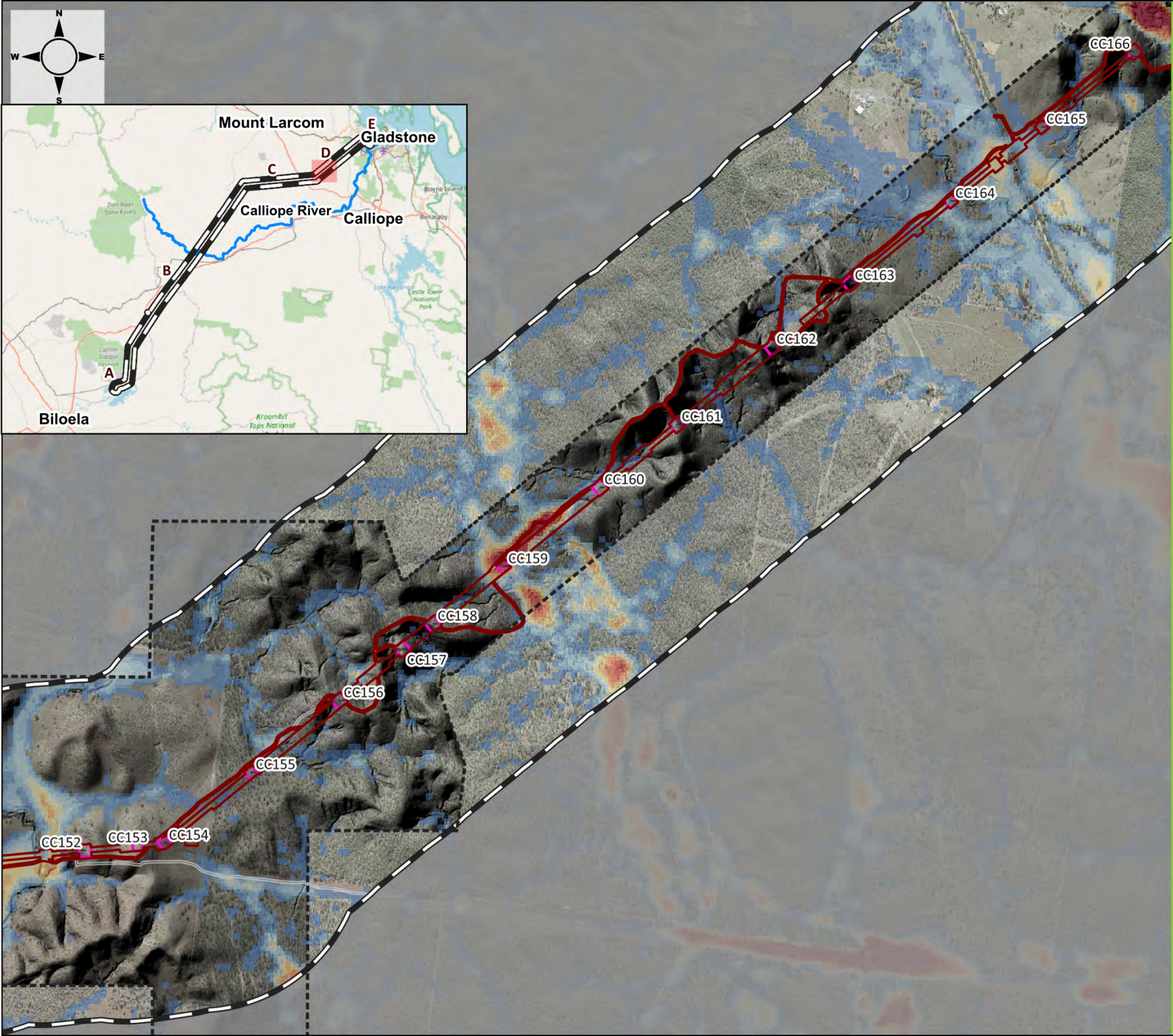

- Legend**
- Project Area
 - Towers
 - 1 m LiDAR Extent
 - Disturbance Footprint
 - Indicative Access Tracks

- Flood depth (m)**
- up to 0.25 m
 - 0.25 to 0.5 m
 - 0.5 to 1.0 m
 - 1.0 to 1.5 m
 - 1.5 to 2.0 m
 - 2.0 to 2.5 m
 - 2.5 to 3.0 m
 - 3.0 to 3.5 m
 - 3.5 to 4.0 m
 - 4.0 to 4.5 m
 - > 4.5 m

Modelling results are based on the best available elevation resolution: Copernicus. The available LiDAR data indicates areas where the elevation and therefore hydraulic model are inconsistent with local survey. All model results should be considered indicative and subject to broader survey validation.

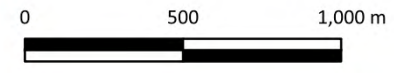

**Calvale to Calliope TL
Surface Water
Impact Assessment**

1% AEP 2090-SSP3 Results
Page 15/18



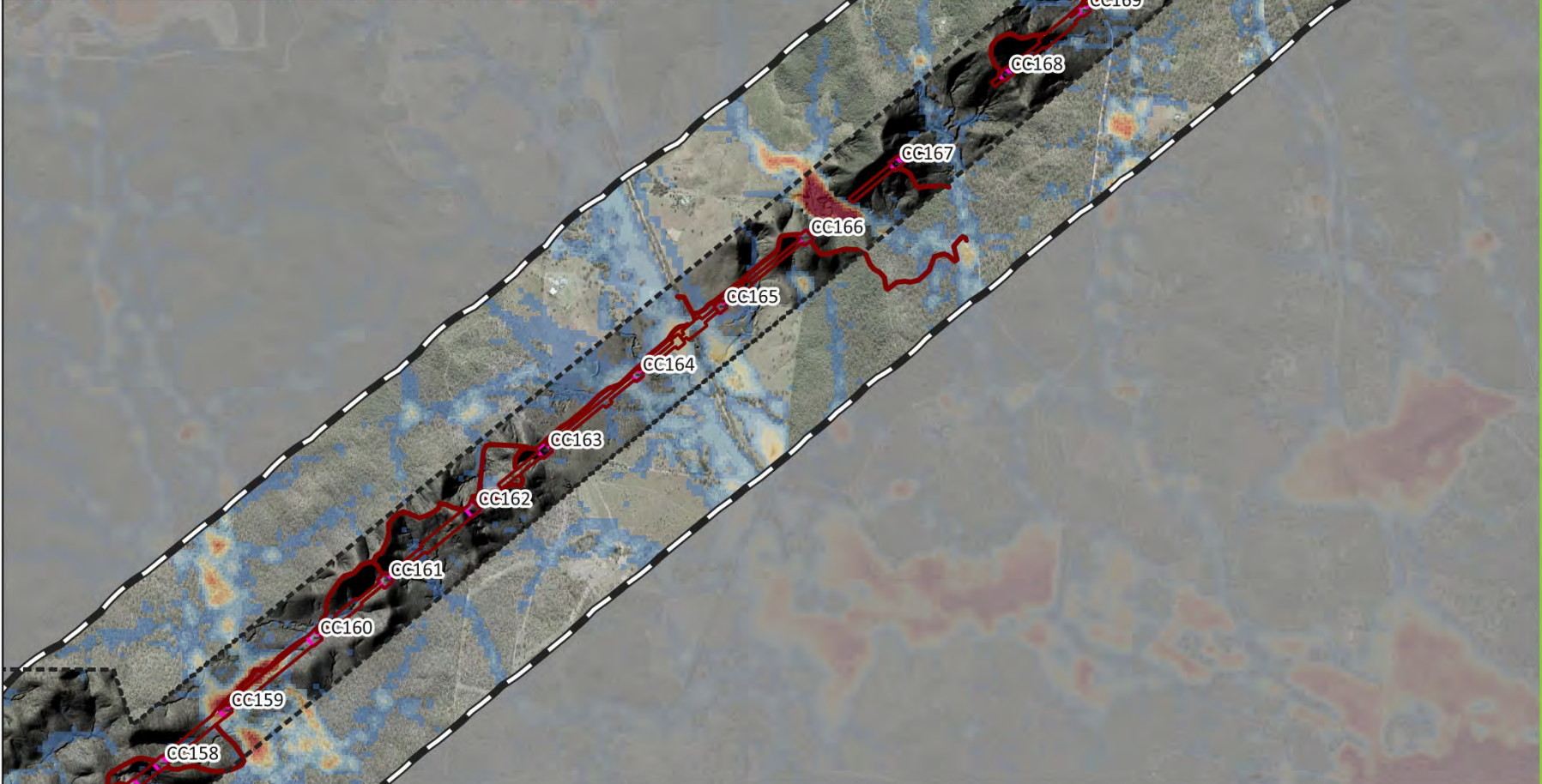
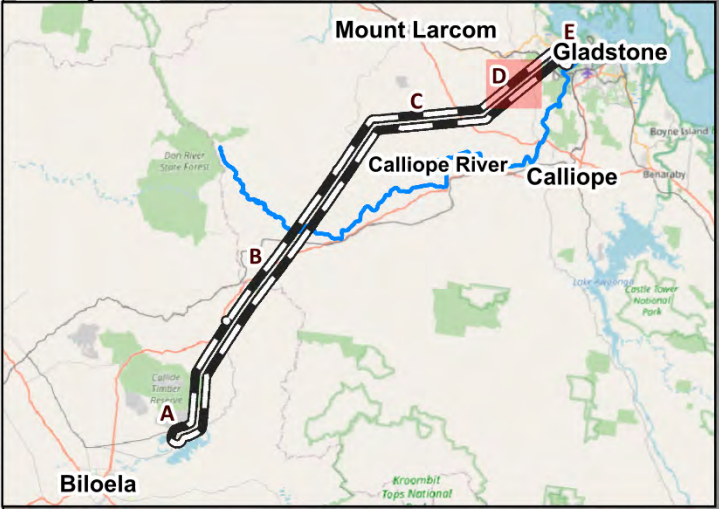

- Legend**
- Project Area
 - Towers
 - 1 m LiDAR Extent
 - Disturbance Footprint
 - Indicative Access Tracks

- Flood depth (m)**
- up to 0.25 m
 - 0.25 to 0.5 m
 - 0.5 to 1.0 m
 - 1.0 to 1.5 m
 - 1.5 to 2.0 m
 - 2.0 to 2.5 m
 - 2.5 to 3.0 m
 - 3.0 to 3.5 m
 - 3.5 to 4.0 m
 - 4.0 to 4.5 m
 - > 4.5 m

Modelling results are based on the best available elevation resolution: Copernicus. The available LiDAR data indicates areas where the elevation and therefore hydraulic model are inconsistent with local survey. All model results should be considered indicative and subject to broader survey validation.

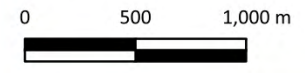

**Calvale to Calliope TL
Surface Water
Impact Assessment**

1% AEP 2090-SSP3 Results
Page 16/18



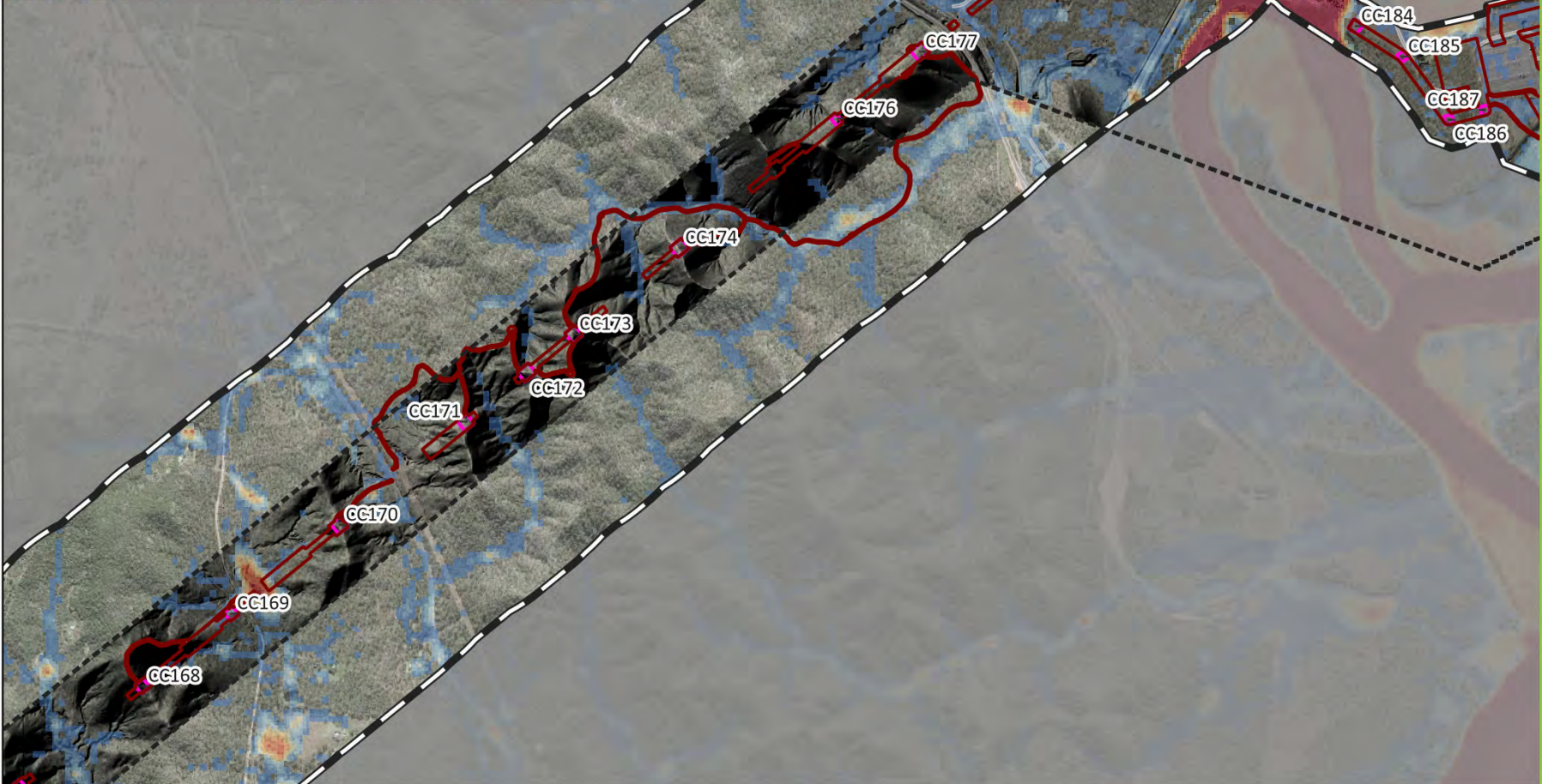

- Legend**
- Project Area
 - Towers
 - 1 m LiDAR Extent
 - Disturbance Footprint
 - Indicative Access Tracks

- Flood depth (m)**
- up to 0.25 m
 - 0.25 to 0.5 m
 - 0.5 to 1.0 m
 - 1.0 to 1.5 m
 - 1.5 to 2.0 m
 - 2.0 to 2.5 m
 - 2.5 to 3.0 m
 - 3.0 to 3.5 m
 - 3.5 to 4.0 m
 - 4.0 to 4.5 m
 - > 4.5 m

Modelling results are based on the best available elevation resolution: Copernicus. The available LiDAR data indicates areas where the elevation and therefore hydraulic model are inconsistent with local survey. All model results should be considered indicative and subject to broader survey validation.

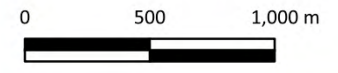

**Calvale to Calliope TL
Surface Water
Impact Assessment**

1% AEP 2090-SSP3 Results
Page 17/18



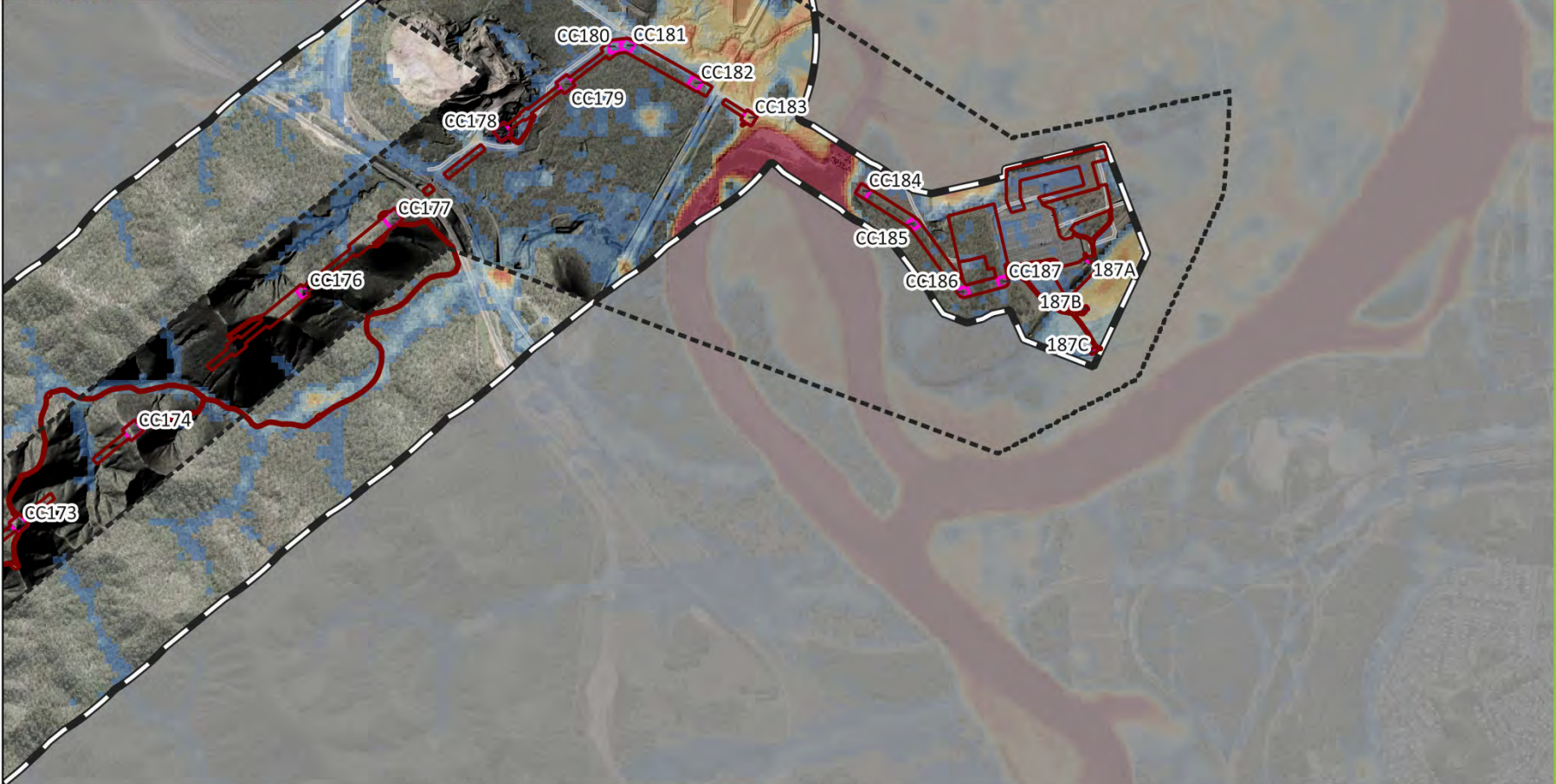

- Legend**
- Project Area
 - Towers
 - 1 m LiDAR Extent
 - Disturbance Footprint
 - Indicative Access Tracks

- Flood depth (m)**
- up to 0.25 m
 - 0.25 to 0.5 m
 - 0.5 to 1.0 m
 - 1.0 to 1.5 m
 - 1.5 to 2.0 m
 - 2.0 to 2.5 m
 - 2.5 to 3.0 m
 - 3.0 to 3.5 m
 - 3.5 to 4.0 m
 - 4.0 to 4.5 m
 - > 4.5 m

Modelling results are based on the best available elevation resolution: Copernicus. The available LiDAR data indicates areas where the elevation and therefore hydraulic model are inconsistent with local survey. All model results should be considered indicative and subject to broader survey validation.



**Calvale to Calliope TL
Surface Water
Impact Assessment**

1% AEP 2090-SSP3 Results
Page 18/18



APPENDIX C TOWER STANDARD DRAWINGS

POWERLINK QUEENSLAND IS THE TRADING NAME OF THE QUEENSLAND ELECTRICITY TRANSMISSION CORPORATION LIMITED ACN 078 849 233
283x394
CAD

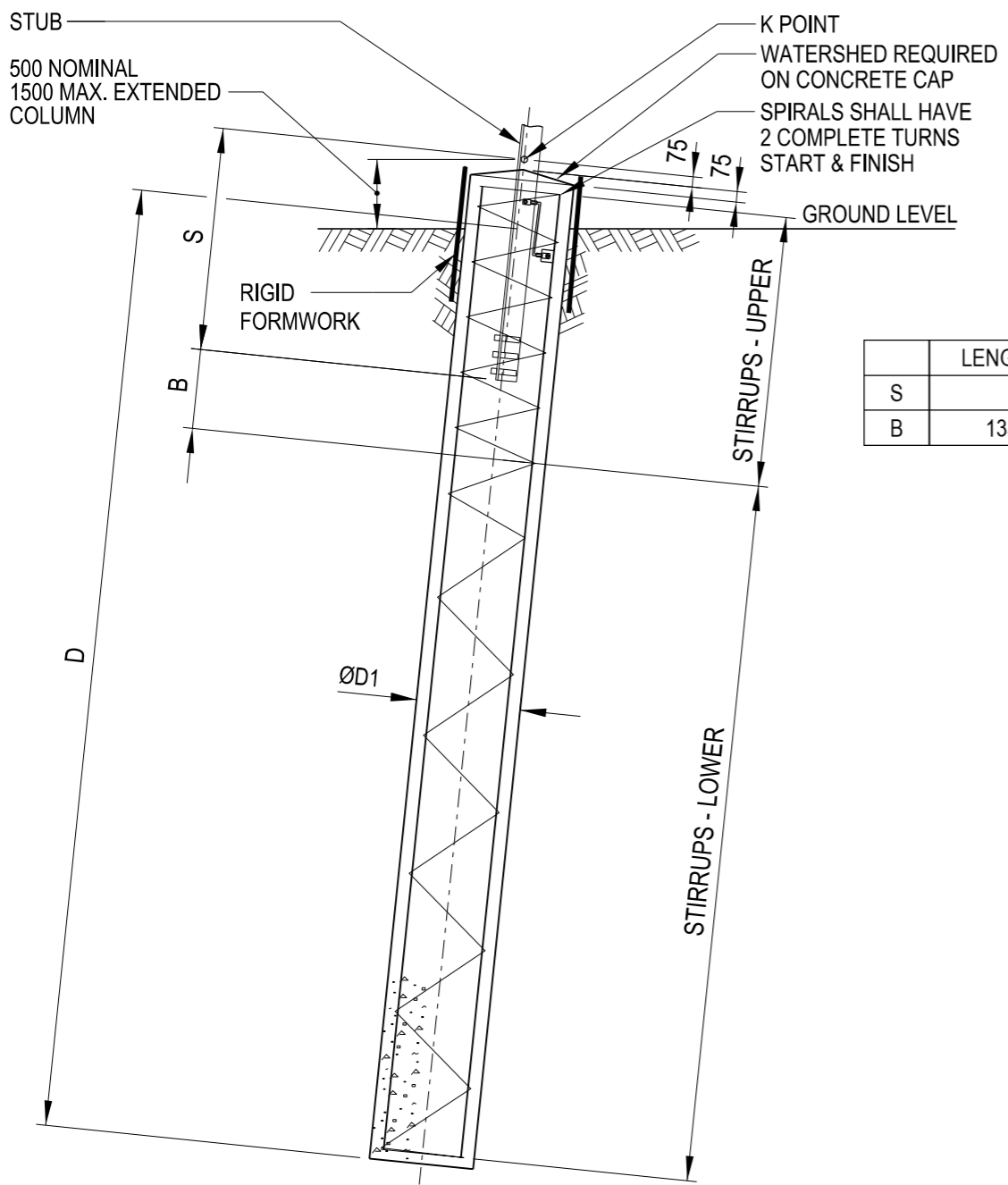

	LENGTH (mm)
S	1800
B	1350 MIN

STUB SIZE	X	Y
L180	601	74
L200	595	80

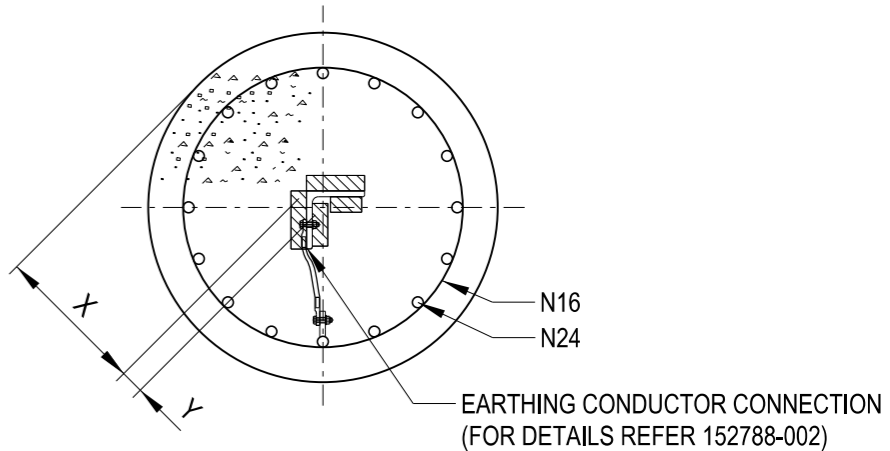

TYPICAL COLUMN CROSS SECTION
NOT TO SCALE

BORED STRAIGHT SIDE FOUNDATION
NOT TO SCALE

GEOTECHNICAL REQUIREMENTS

1. THIS FOUNDATION TYPE IS APPLICABLE ONLY TO SITES WITH DENSE OR STRONGER NON-COHESIVE SOILS, CEMENTED SANDS, AND/OR ROCK OF LESS THAN LOW MASS STRENGTH THAT CANNOT BE UNDER-CUT.
2. WHERE LOWER STRENGTH MATERIALS, EXPANSIVE SOILS AND/OR SATURATED CONDITIONS ARE ENCOUNTERED, OR LINERS REQUIRED TO FACILITATE BORING, CONTACT THE DESIGNER FOR AN ALTERNATIVE DESIGN.
3. GEOTECHNICAL MATERIAL AND STRENGTH CLASSIFICATION SHALL BE IN ACCORDANCE WITH AS 1726.
4. EACH INDIVIDUAL FOOTING SHALL BE COMPLETED WITHIN 48 HOURS OF BORING. FOR LONGER DURATIONS, CONTACT THE DESIGNER FOR AN ALTERNATIVE DESIGN.
5. THE CONTRACTOR SHALL BE RESPONSIBLE FOR ALL FOUNDATION CONSTRUCTION ISSUES. THE CONTRACTOR SHALL ALLOW FOR BORING IN SOIL WITH COBBLE/BOULDER AND ROCK OF LESS THAN LOW MASS STRENGTH.
6. IF BORED FOUNDATION IS ABANDONED, THE NEW POSITION SHALL NOT BE CLOSER THAN 3.0 METRES MEASURED BETWEEN THE HOLES EDGES.
7. EARTHWORKS SHALL COMPLY WITH POWERLINK TRANSMISSION LINES SPECIFICATION.
8. DEWATERING IS PERMITTED ONLY IF ITS APPLICATION WILL NOT DETERIORATE THE SOIL PROPERTIES. RPEQ SHALL APPROVE THE DEWATERING PROCEDURE.
9. THE DESIGN PRINCIPLES ARE BASED ON AS/NZS 7000.

CONCRETE NOTES

- C1. ALL CONCRETE WORK SHALL CONFORM TO AS 3600 "CONCRETE STRUCTURES" AND POWERLINK SPECIFICATION.
- C2. CONCRETE TO BE S32, MINIMUM CONCRETE COVER TO BE 75mm.
- C3. ALL REINFORCEMENT SHALL CONFORM WITH AS/NZS 4671 "STEEL REINFORCING MATERIAL" AND SHALL BE DESIGNATED AS FOLLOWS:
 - a. R - PLAIN ROUND BAR, STRENGTH GRADE 250 MPa, NORMAL DUCTILITY (e.g. R10 DESIGNATES R250N10)
 - b. N - DEFORMED RIBBED BARS, STRENGTH GRADE 500 MPa, NORMAL DUCTILITY (e.g. N24 DESIGNATES D500N24)
- C4. CONCRETE VOLUMES ARE INDICATIVE ONLY.
- C5. DIMENSIONS ARE IN MILLIMETRES U.N.O.

TOWER LEVELS	COLUMN HEIGHTS	D	D1	COLUMN REINFORCING		STUB SIZE	VOLUME OF CONCRETE m ³ REFER NOTE C4
				LONGITUDINAL	STIRRUPS N16 SPIRALS		
-10 TO -5	500 - 1500	8000	1350	16- N24	UPPER @ 300 CENTRES	L 180x180x18 GR 350	12.20
					LOWER @ 330 CENTRES		
-4 TO +22	500 - 1500	9700	1350	16- N24	UPPER @ 290 CENTRES	L 200x200x20 GR 350	14.50
					LOWER @ 330 CENTRES		

ORIGINAL ISSUE DATE:	PRELIMINARY NOT FOR CONSTRUCTION DATE: 06/12/2024	CHECKED	<i>M</i>	DESIGNED	<i>[Signature]</i>	Powerlink QUEENSLAND	LOCATION	CONTIORDER	PROJECT	DRG CLASS		
		DRAWN	<i>Bh</i>	DESIGN CHKD			HLHD		-	A2		
		ORIGIN	TLD	APPROVED			275kV DOUBLE CIRCUIT STEEL TOWER STRUCTURE TYPE D2S2V1 INTERNATIONAL STEEL BORED STRAIGHT SIDE FOUNDATION				A3-H-159777-013	NEXT SHEET 014
		CIRCULATION									A	

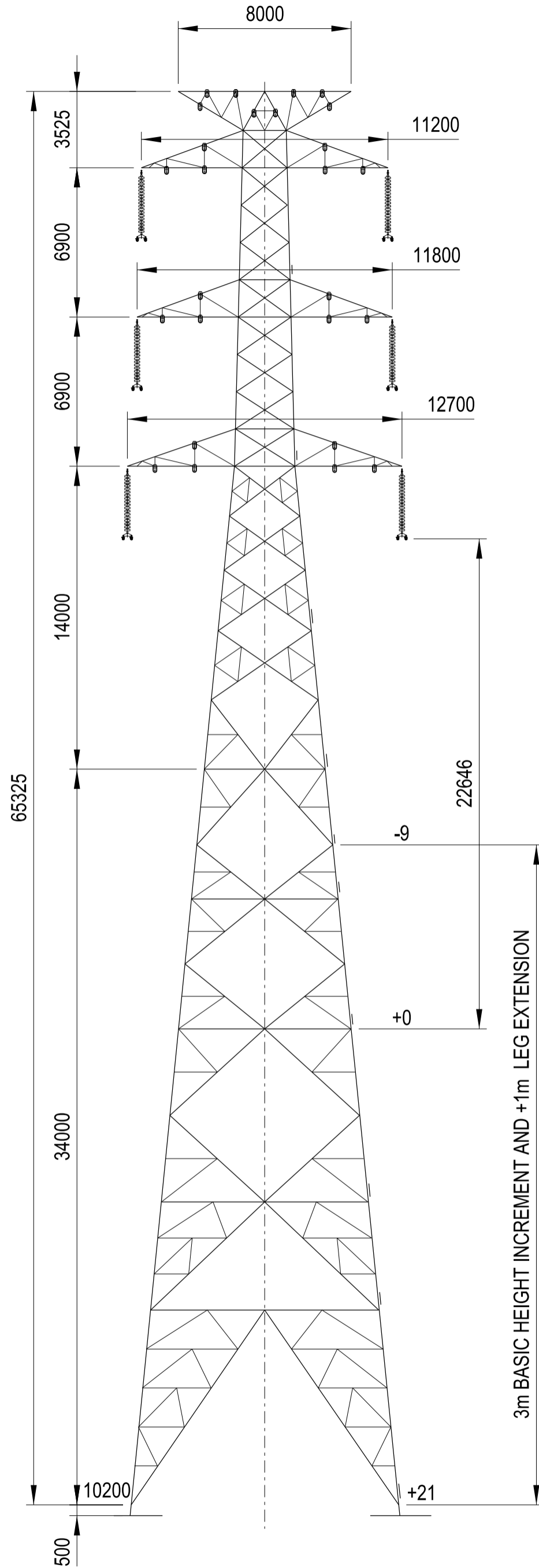

PRINCIPAL STRUCTURE
DIMENSIONS

NOT TO SCALE

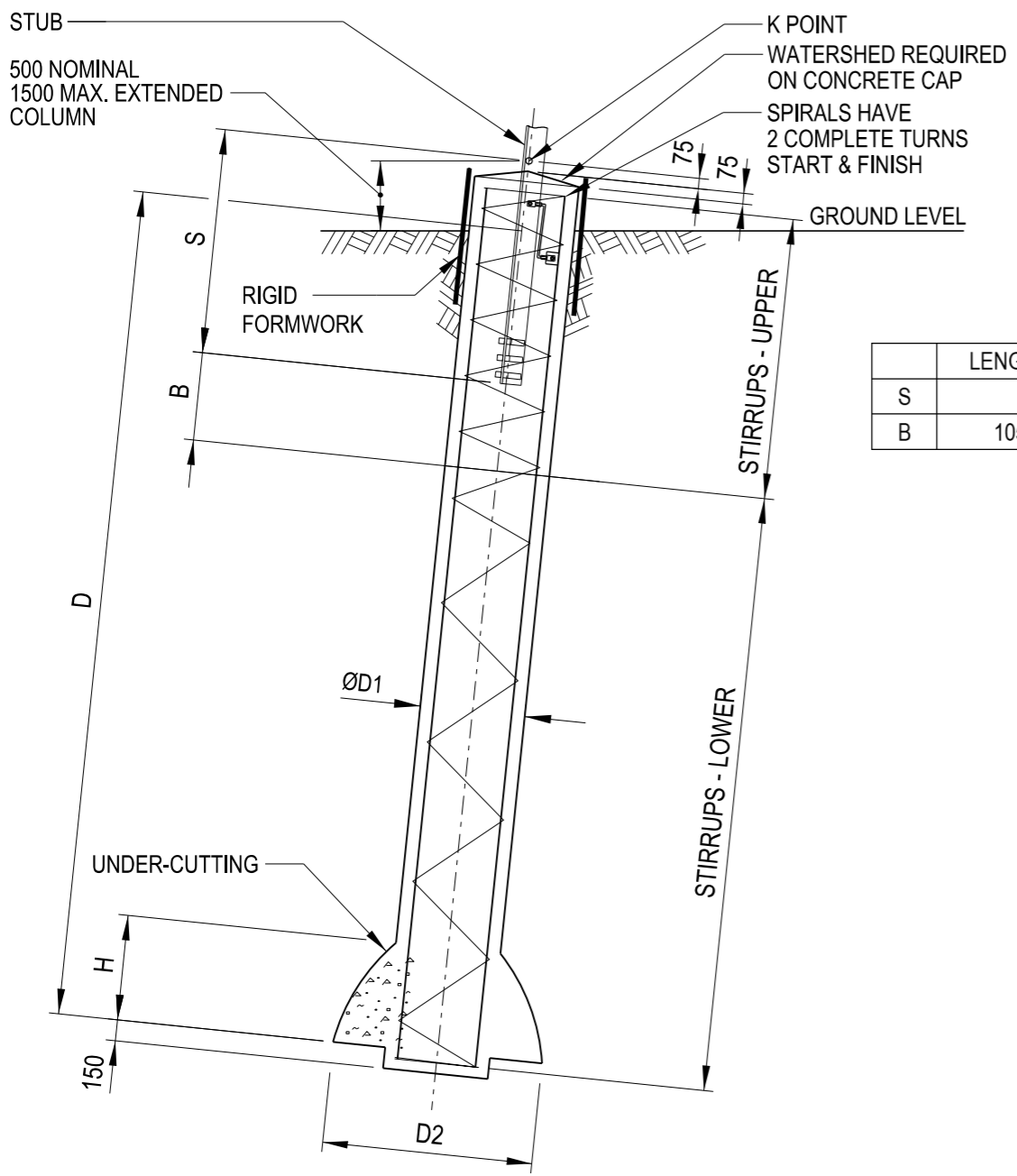

	LENGTH (mm)
S	1800
B	1050 MIN

BORED UNDER-CUT FOUNDATION
NOT TO SCALE

STUB SIZE	X	Y
L180	451	74
L200	445	80

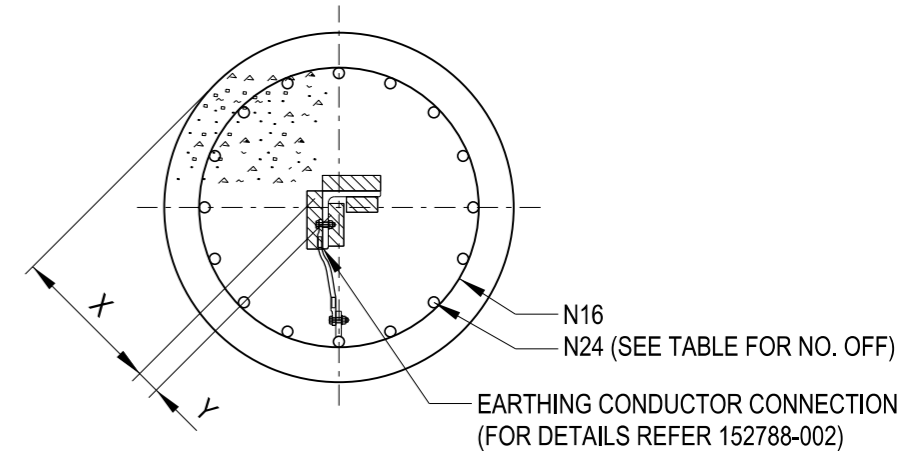

TYPICAL COLUMN CROSS SECTION
NOT TO SCALE

GEOTECHNICAL REQUIREMENTS

1. THIS FOUNDATION TYPE IS APPLICABLE ONLY TO SITES WITH STIFF OR STRONGER COHESIVE SOILS AS PER TABLE BELOW, CEMENTED SANDS, DENSE OR STRONGER NON-COHESIVE SOILS AND/OR ROCK OF LESS THAN LOW MASS STRENGTH THAT CAN BE UNDER-CUT.

GEOTECHNICAL PROPERTIES OF CLAY - MINIMUM REQUIREMENT		
DEPTH (m)	GROUND CONDITION	Cu (kPa)
0m - 5m	STIFF CLAY	75
>5m	VERY STIFF CLAY	137

2. WHERE LOWER STRENGTH MATERIALS, EXPANSIVE SOILS AND/OR SATURATED CONDITIONS ARE ENCOUNTERED, OR LINERS REQUIRED TO FACILITATE BORING, CONTACT THE DESIGNER FOR AN ALTERNATIVE DESIGN.
3. GEOTECHNICAL MATERIAL AND STRENGTH CLASSIFICATION SHALL BE IN ACCORDANCE WITH AS 1726.
4. EACH INDIVIDUAL FOOTING SHALL BE COMPLETED WITHIN 48 HOURS OF BORING. FOR LONGER DURATIONS, CONTACT THE DESIGNER FOR AN ALTERNATIVE DESIGN.
5. THE CONTRACTOR SHALL BE RESPONSIBLE FOR ALL FOUNDATION CONSTRUCTION ISSUES. THE CONTRACTOR SHALL ALLOW FOR BORING IN SOIL WITH COBBLE/BOULDER AND ROCK OF LESS THAN LOW MASS STRENGTH.
6. IF BORED FOUNDATION IS ABANDONED, THE NEW POSITION SHALL NOT BE CLOSER THAN 3.0 METRES MEASURED BETWEEN THE HOLES EDGES.
7. EARTHWORKS SHALL COMPLY WITH POWERLINK TRANSMISSION LINES SPECIFICATION.
8. DEWATERING IS PERMITTED ONLY IF ITS APPLICATION WILL NOT DETERIORATE THE SOIL PROPERTIES. RPEQ SHALL APPROVE THE DEWATERING PROCEDURE.
9. THE DESIGN PRINCIPLES ARE BASED ON AS/NZS 7000.

CONCRETE NOTES

- C1. ALL CONCRETE WORK SHALL CONFORM TO AS 3600 "CONCRETE STRUCTURES" AND POWERLINK SPECIFICATION.
- C2. CONCRETE TO BE S32, MINIMUM CONCRETE COVER TO BE 75mm.
- C3. ALL REINFORCEMENT SHALL CONFORM WITH AS/NZS 4671 "STEEL REINFORCING MATERIAL" AND SHALL BE DESIGNATED AS FOLLOWS:
 - a. R - PLAIN ROUND BAR, STRENGTH GRADE 250 MPa, NORMAL DUCTILITY (e.g. R10 DESIGNATES R250N10)
 - b. N - DEFORMED RIBBED BARS, STRENGTH GRADE 500 MPa, NORMAL DUCTILITY (e.g. N24 DESIGNATES D500N24)
- C4. CONCRETE VOLUMES ARE INDICATIVE ONLY.
- C5. DIMENSIONS ARE IN MILLIMETRES U.N.O.

TOWER LEVELS	COLUMN HEIGHTS	D	D1	D2	H	COLUMN REINFORCING		STUB SIZE	VOLUME OF CONCRETE m ³ REFER NOTE C4	
						LONGITUDINAL	STIRRUPS N16 SPIRALS			
-10 TO -5	500 - 1500	6100	1050	2100	1050	12 - N24	UPPER	@ 300 CENTRE	L 180x180x18 GR 350	7.40
							LOWER	@ 360 CENTRE		
-4 TO +22	500 - 1500	6400	1050	2100	1050	16 - N24	UPPER	@ 250 CENTRE	L 200x200x20 GR 350	7.70
							LOWER	@ 360 CENTRE		

ORIGINAL ISSUE DATE:	<p>PRELIMINARY NOT FOR CONSTRUCTION DATE: 06/12/2024</p>	CHECKED	<i>AM</i>	DESIGNED	<i>[Signature]</i>
		DRAWN	<i>Bh</i>	DESIGN CHKD	
		ORIGIN	TLD	APPROVED	
		CIRCULATION			

Powerlink QUEENSLAND		LOCATION	CONTIORDER	PROJECT	DRG CLASS	
<p>275kV DOUBLE CIRCUIT STEEL TOWER STRUCTURE TYPE D2S2V1 INTERNATIONAL STEEL BORED UNDER-CUT FOUNDATION</p>		HLHD		-	A2	
		A3-H-159777-011			NEXT SHEET	012
		A				

POWERLINK QUEENSLAND IS THE TRADING NAME OF THE QUEENSLAND ELECTRICITY TRANSMISSION CORPORATION LIMITED ACN 078 849 233
283x394
CAD

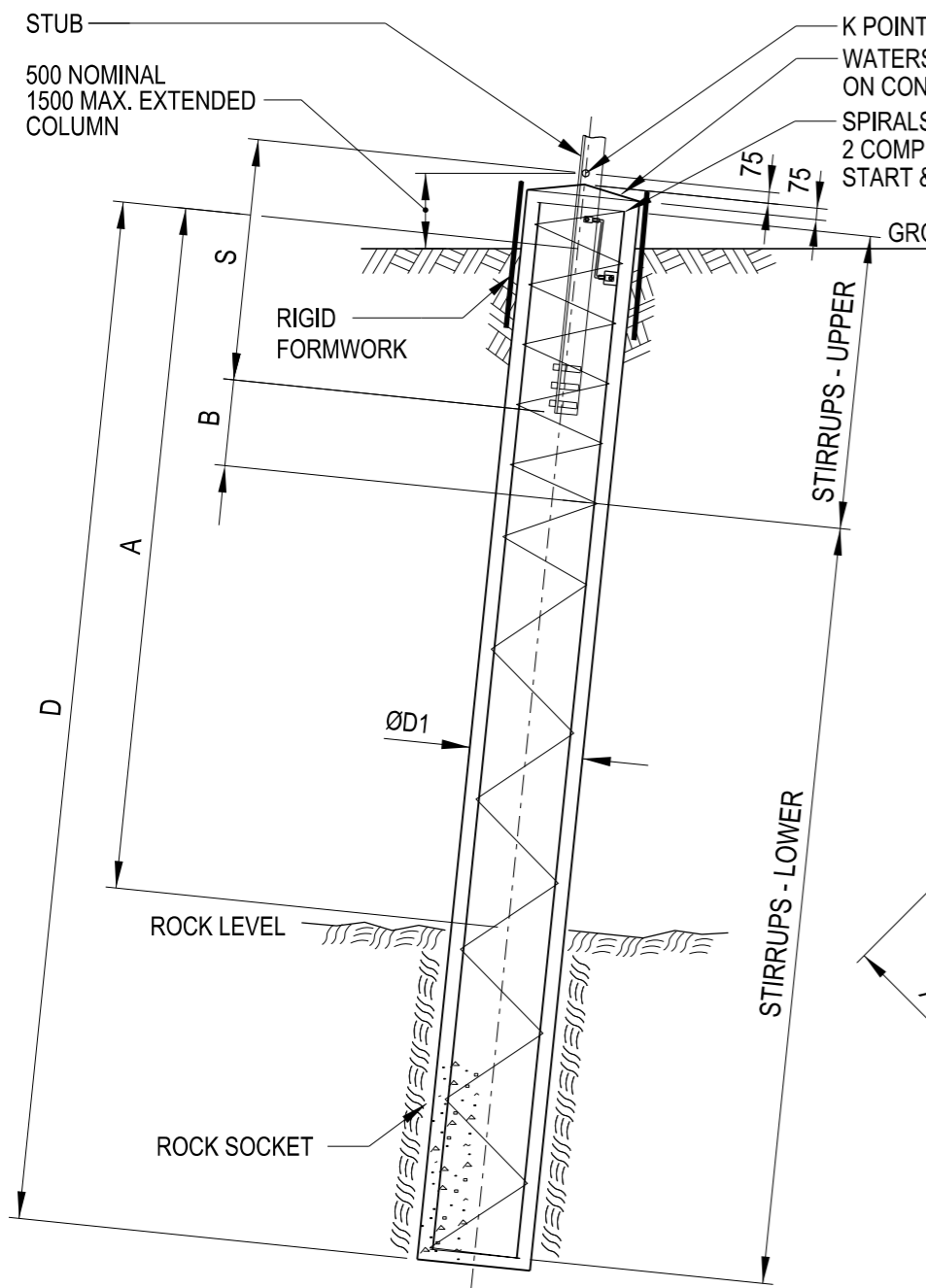

	LENGTH (mm)
S	1800
B	1050 MIN

STUB SIZE	X	Y
L180	451	74
L200	445	80

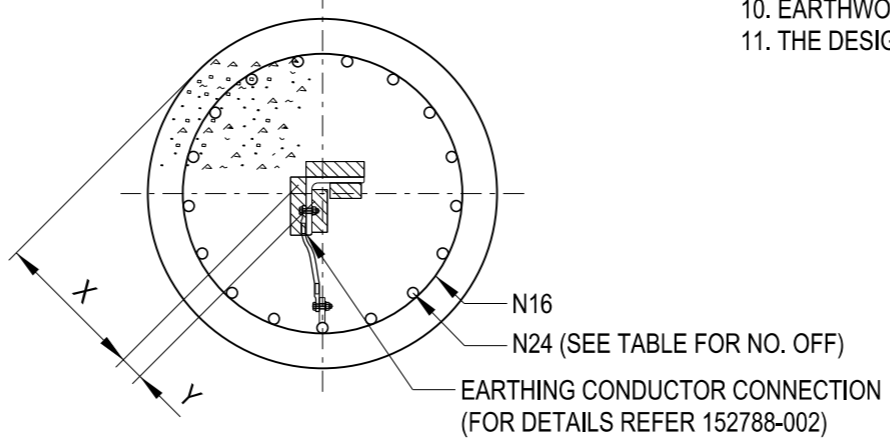

TYPICAL COLUMN CROSS SECTION
NOT TO SCALE

CONCRETE NOTES

- C1. ALL CONCRETE WORK SHALL CONFORM TO AS 3600 "CONCRETE STRUCTURES" AND POWERLINK SPECIFICATION.
- C2. CONCRETE TO BE S32 TO THE POWERLINK SPECIFICATION, MINIMUM CONCRETE COVER TO BE 75mm.
- C3. ALL REINFORCEMENT SHALL CONFORM WITH AS/NZS 4671 "STEEL REINFORCING MATERIAL" AND SHALL BE DESIGNATED AS FOLLOWS:
 - a. R - PLAIN ROUND BAR, STRENGTH GRADE 250 MPa, NORMAL DUCTILITY (e.g. R10 DESIGNATES R250N10)
 - b. N - DEFORMED RIBBED BARS, STRENGTH GRADE 500 MPa, NORMAL DUCTILITY (e.g. N24 DESIGNATES D500N24)
- C4. CONCRETE VOLUMES ARE INDICATIVE ONLY.
- C5. DIMENSIONS ARE IN MILLIMETRES U.N.O.

GEOTECHNICAL REQUIREMENTS

1. THIS FOUNDATION TYPE IS APPLICABLE ONLY TO SITES WITH UNDERLYING ROCK OF A MINIMUM LOW MASS STRENGTH.
2. WHERE EXPANSIVE SOILS AND/OR SATURATED CONDITIONS ARE ENCOUNTERED, OR LINERS REQUIRED TO FACILITATE BORING, CONTACT THE DESIGNER FOR AN ALTERNATIVE DESIGN.
3. UNDERLYING ROCK SHALL BE CONTINUOUS AND ROCK LAYERS ARE NOT SUITABLE.
4. IN HARD ROCK PEPPERING AND/OR BLASTING MAY BE REQUIRED TO COMPLETE THE FOUNDATION.
5. THE ROCK SOCKET SIDEWALLS SHALL BE FREE OF CRUSHED/SMEARED ROCK AND HAVE INTERNAL SURFACE REAMED TO ACHIEVE A GROOVE SPIRAL OVER ROCK SOCKET.
6. WHERE THE DEPTH ABOVE THE ROCK LEVEL IS GREATER THAN 3 METRES, EACH INDIVIDUAL FOOTING SHALL BE COMPLETED WITHIN 48 HOURS OF BORING. FOR LONGER DURATIONS CONTACT THE DESIGN ENGINEER FOR ALTERNATIVE DESIGN.
7. GEOTECHNICAL MATERIAL AND STRENGTH CLASSIFICATION SHALL BE IN ACCORDANCE WITH AS 1726.
8. THE CONTRACTOR SHALL BE RESPONSIBLE FOR ALL FOUNDATION CONSTRUCTION ISSUES. THE CONTRACTOR SHALL ALLOW FOR BORING IN OVERLYING SOIL WITH COBBLE AND ROCK LAYERS OF LESS THAN LOW MASS STRENGTH.
9. IF THE FOUNDATION IS ABANDONED, THE NEW POSITION SHALL NOT BE CLOSER THAN 3.0 METRES MEASURED BETWEEN THE HOLES EDGES.
10. EARTHWORKS SHALL COMPLY WITH POWERLINK TRANSMISSION LINES SPECIFICATION.
11. THE DESIGN PRINCIPLES ARE BASED ON AS/NZS 7000.

ULTIMATE LIMIT STATE PARAMETERS - MINIMUM REQUIREMENTS	
ROCK TYPE	SHAFT ADHESION, f_s (kPa)
LOW MASS STRENGTH ROCK	300
MEDIUM / HIGH MASS STRENGTH ROCK	800

ROCK MASS STRENGTH	-10 To -5				-4 To -22			
	LOW		MEDIUM / HIGH		LOW		MEDIUM / HIGH	
	A	D	VOLUME OF CONCRETE m^3 REFER NOTE C4	D	VOLUME OF CONCRETE m^3 REFER NOTE C4	D	VOLUME OF CONCRETE m^3 REFER NOTE C4	D
0	4000	3.89	3800	3.76	4400	4.28	4300	4.14
300	4000	3.91	3900	3.80	4500	4.29	4300	4.17
600	4100	3.94	4000	3.85	4500	4.33	4400	4.23
900	4100	3.98	4000	3.91	4500	4.36	4500	4.29
1200	4200	4.04	4100	3.97	4600	4.42	4500	4.35
1500	4200	4.09	4200	4.04	4700	4.47	4600	4.41
1800	4300	4.16	4300	4.12	4700	4.53	4700	4.49
2100	4400	4.23	4400	4.20	4800	4.6	4800	4.55
2400	4500	4.30	4400	4.28	4900	4.67	4900	4.64
2700	4600	4.38	4500	4.36	5000	4.77	5000	4.73
3000	4700	4.47	4700	4.46	5200	4.97	5100	4.81
3300	4900	4.63	4800	4.55	5500	5.18	5200	4.90
3600	5100	4.85	4900	4.65	5700	5.4	5300	5.00
3900	5300	5.04	5000	4.75	6000	5.59	5400	5.09
4200	5600	5.26	5300	4.98	6200	5.81	5500	5.20
4500	5800	5.48	5600	5.24	6500	6.03	5600	5.29
4800	6000	5.66	5900	5.50	6700	6.25	5900	5.50
5100	6300	5.89	6200	5.76	7000	6.46	6200	5.76
5400	6500	6.10	6500	6.02	7200	6.66	6500	6.02
5700	6800	6.30	6800	6.28	7400	6.87	6800	6.28
6000	7100	6.54	7100	6.54	7700	7.1	7100	6.54
6300	7400	6.80	7400	6.80	7900	7.3	7400	6.80
6600	7700	7.06	7700	7.06	8100	7.48	7700	7.06
6900	8000	7.32	8000	7.32	8400	7.73	8000	7.32
7200	8300	7.58	8300	7.58	8700	7.92	8300	7.58
7500	8600	7.84	8600	7.84	8900	8.12	8600	7.84
7800	8900	8.10	8900	8.10	9200	8.36	8900	8.10
8100	9200	8.36	9200	8.36	9400	8.58	9200	8.36
8400	9500	8.62	9500	8.62	9700	8.8	9500	8.62
8700	9800	8.88	9800	8.88	9900	9.01	9800	8.88

TOWER LEVELS	COLUMN HEIGHTS	D1	COLUMN REINFORCING		STUB SIZE
			LONGITUDINAL	STIRRUPS N16 SPIRAL	
-10 TO -5	500 - 1500	1050	13 - N24	UPPER @ 300 CENTRE LOWER @ 360 CENTRE	L 180x180x18 GR 350
-4 TO +22	500 - 1500	1050	17 - N24	UPPER @ 250 CENTRE LOWER @ 360 CENTRE	L 200x200x20 GR 350

CHECKED	<i>AM</i>	DESIGNED	<i>ASAP</i>
DRAWN	<i>Bh</i>	DESIGN CHKD	
ORIGIN	TLD	APPROVED	
CIRCULATION			

Powerlink QUEENSLAND

**275kV DOUBLE CIRCUIT STEEL TOWER
STRUCTURE TYPE D2S2V1
INTERNATIONAL STEEL
BORED AND SOCKETED FOUNDATION**

LOCATION	CONTIORDER	PROJECT	DRG CLASS
HLHD		-	A2
A3-H-159777-012			NEXT SHEET 013
A			

**PRELIMINARY
NOT FOR CONSTRUCTION**
DATE: 06/12/2024



1160-STR-6049

CalliopeRiver-Bouldercombe

Feeder No: F812

Date: 29-Sep-15

Time: 10:05:24

MGA Zone 56

E:315811.7

N:7360666.93



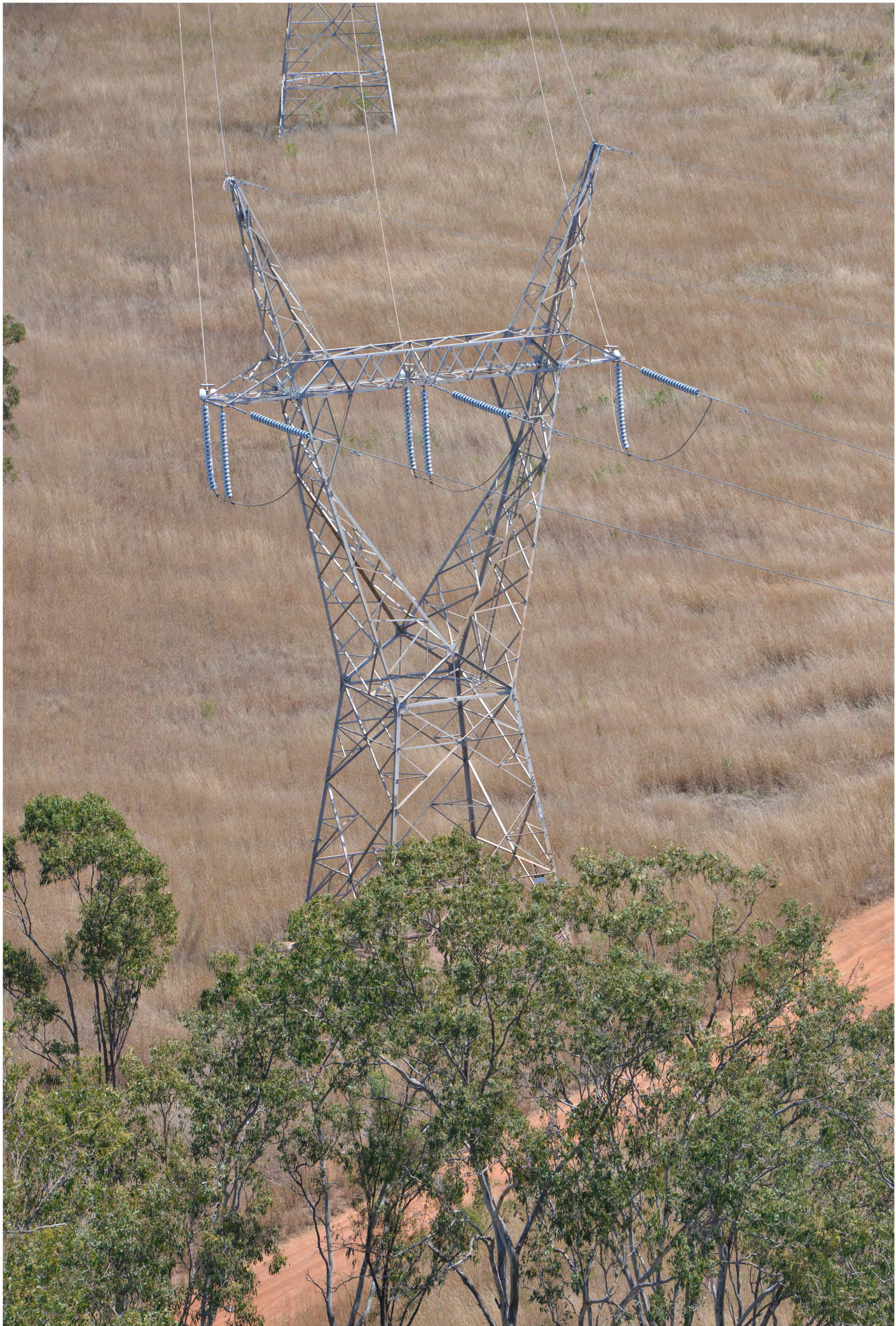

1161-STR-0008

CalliopeRiver-Bouldercombe

Feeder No: F812

Date: 30-Sep-15

Time: 11:03:54

MGA Zone 56

E:315435.57

N:7360627.53





1161-STR-0009

CalliopeRiver-Bouldercombe

Feeder No: F812

Date: 30-Sep-15

Time: 11:04:01

MGA Zone 56

E:315261.83

N:7360734.29



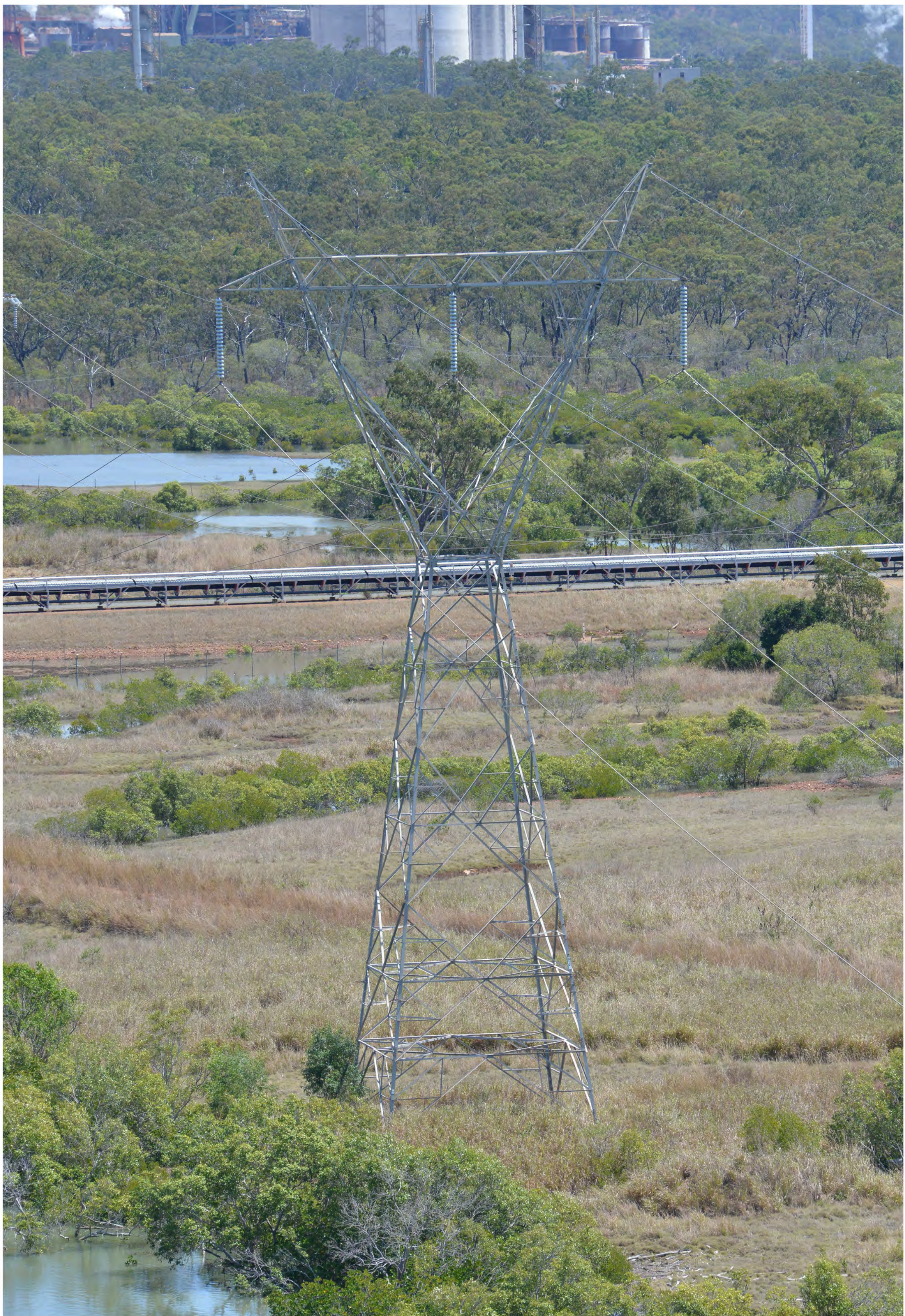

1161-STR-0010

CalliopeRiver-Bouldercombe

Feeder No: F812

Date: 30-Sep-15

Time: 11:04:20

MGA Zone 56

E:314876.17

N:7360988.76





1161-STR-0011

CalliopeRiver-Bouldercombe

Feeder No: F812

Date: 30-Sep-15

Time: 11:04:35

MGA Zone 56

E:314510.66

N:7361212.97





1121-STR-0012

CalliopeRiver-Bouldercombe

Feeder No: F812

Date: 30-Sep-15

Time: 11:04:51

MGA Zone 56

E:314210.01

N:7361379.74





1121-STR-0013

CalliopeRiver-Bouldercombe

Feeder No: F812

Date: 30-Sep-15

Time: 11:05:38

MGA Zone 56

E:314129.06

N:7361379.72





1121-STR-0014

CalliopeRiver-Bouldercombe

Feeder No: F812

Date: 30-Sep-15

Time: 11:05:51

MGA Zone 56

E:313848.16

N:7361172.13



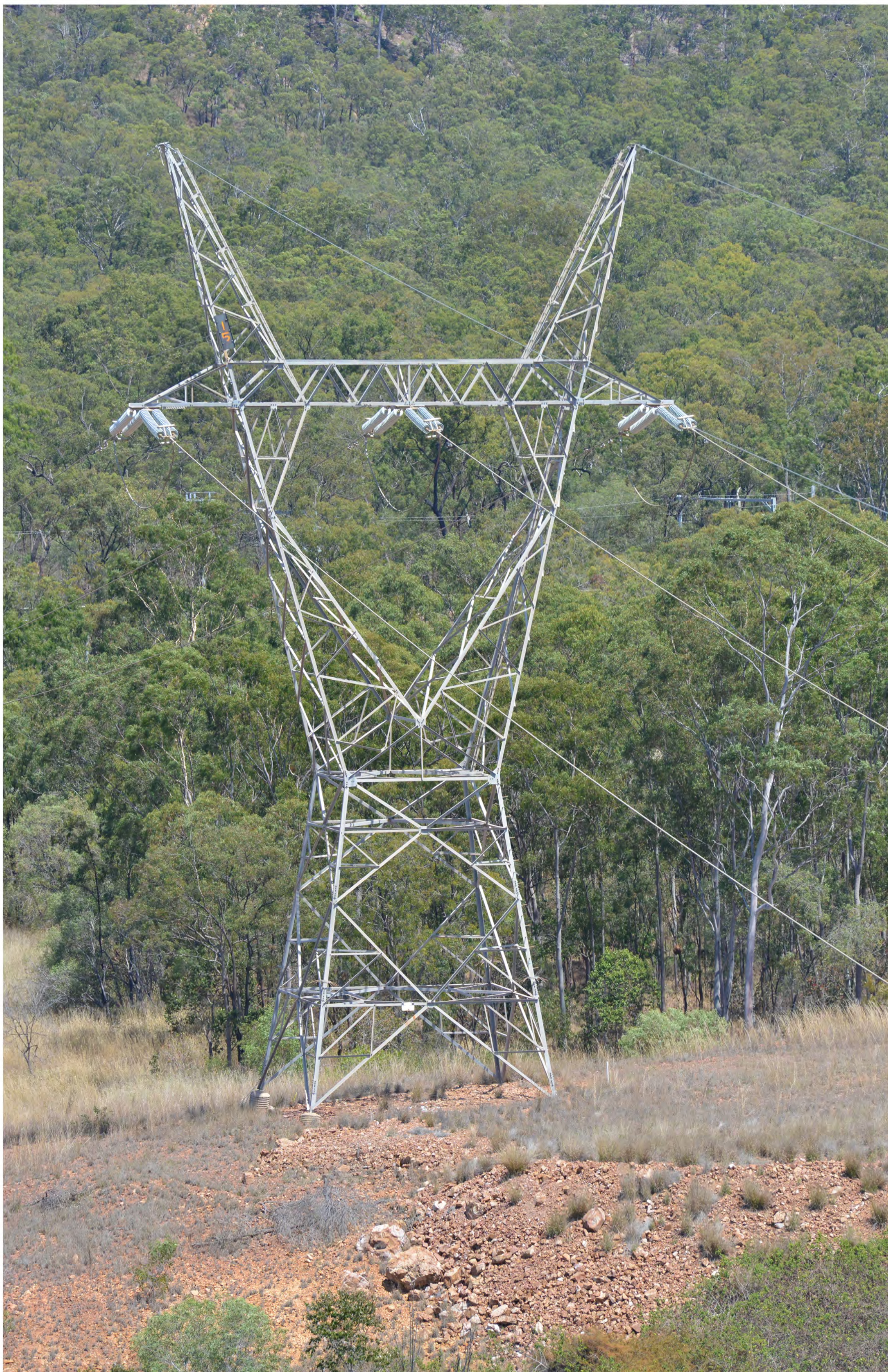

1121-STR-0015

CalliopeRiver-Bouldercombe

Feeder No: F812

Date: 30-Sep-15

Time: 11:06:01

MGA Zone 56

E:313636.27

N:7361006.06



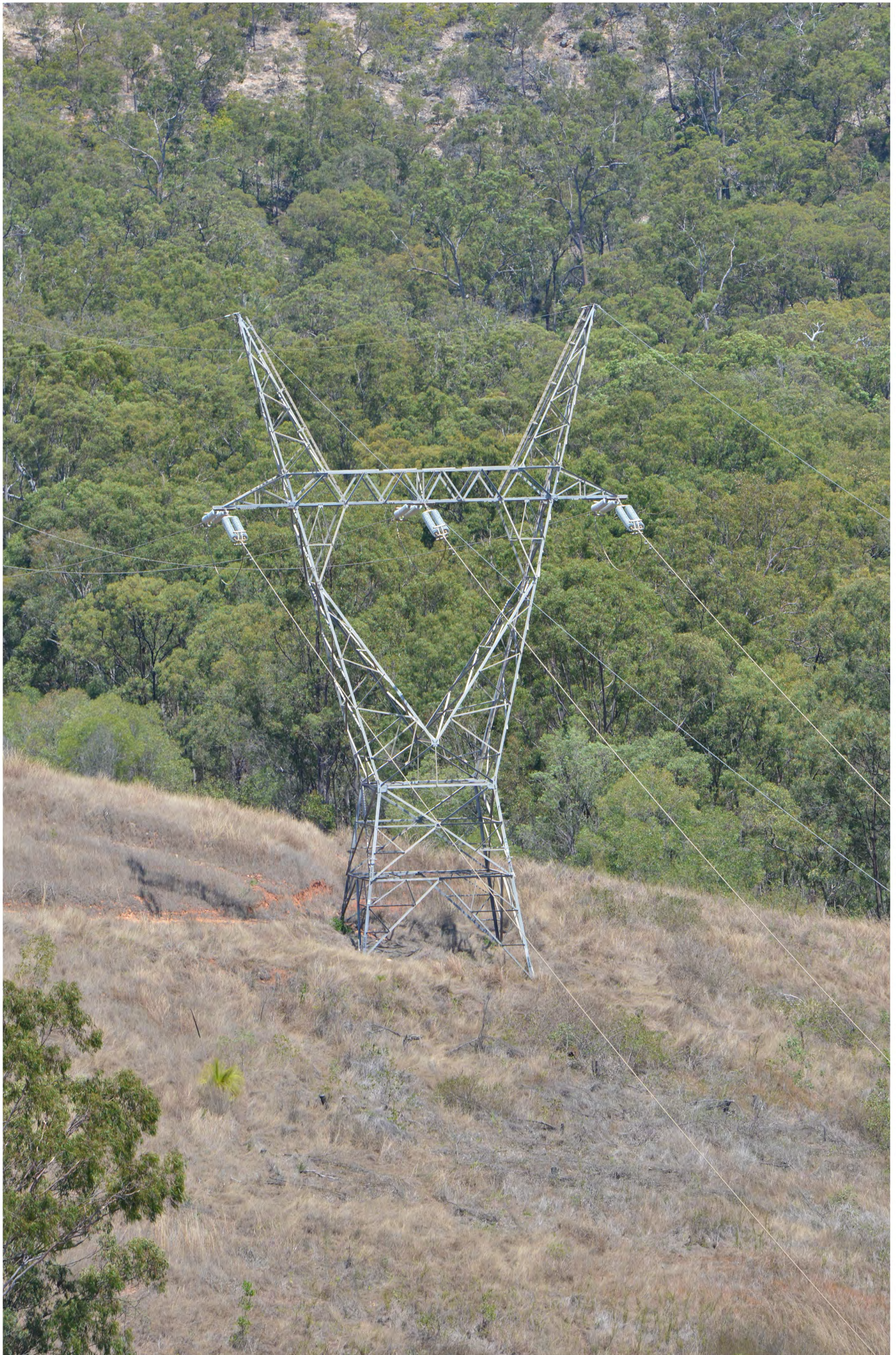

1121-STR-0016

CalliopeRiver-Bouldercombe

Feeder No: F812

Date: 30-Sep-15

Time: 11:06:21

MGA Zone 56

E:313159.94

N:7360629.05





Level 1, 369 Ann Street Brisbane
PO Box 10703 Brisbane Adelaide Street Qld 4000
07 3225 0200

Level 5, 93 Mitchell Street Darwin
GPO Box 43348 Casuarina NT 0811
08 8911 0060

wrm@wrmwater.com.au
wrmwater.com.au

ABN 96 107 404 544